

# *In situ* evaluation of ground heat exchanger performances installed at Blake Group facility, East Windsor, Ct

María Isabel Vélez Márquez

Jean-François Lavoie

Jeff Harrison

Mathieu Brousseau

Jasmin Raymond

June 2018



## Abstract

Ground coupled heat pump systems, composed of a ground heat exchangers and a heat pump are an efficient and environmentally friendly technology to cool and heat building. Heat exchangers are one expensive component of the system. Borehole thermal resistance, which is the ability of the ground heat exchanger to resist heat transfer, is one of the parameters considered in the determination of the heat exchanger length. Versaprofiles, a Canadian company, has developed a thermally enhanced pipe to reduce the borehole thermal resistance, and consequently the borehole length, another expensive component of the system. *In situ* estimation of borehole thermal properties of enhanced and standard pipes made at Blake Group facility allowed in this work to evaluate the potential borehole length saving provided by the enhanced pipe. In a second step, the experimental data was used to predict the system performance through analytical simulations and assess the benefits of the thermally enhanced pipe over the standard system commonly used.



© INRS, Centre - Eau Terre Environnement, 2018

Tous droits réservés

ISBN : 978-2-89146-916-6 (version électronique)

Dépôt légal - Bibliothèque et Archives nationales du Québec, 2019 Dépôt légal -

Bibliothèque et Archives Canada, 2019

## TWINLOOP™

TWINLOOP™ geothermal  
HDPE double U-bend PIPE



## VERSAPIPE® HD100 G10

A reliable choice.  
Black geothermal PE3608  
high-density polyethylene  
pipe certified to NSF 358,  
ANSI/CSA C448, CSA  
B1371 and ASTM D3035.



## VERSAPIPE® HD100 G10

The next generation.  
Black geothermal PE4710  
high-density polyethylene  
pipe certified to NSF 358,  
ANSI/CSA C448, CSA  
B1371, and ASTM D3035.



## GEOPERFORMX® V2

High efficiency.  
Made with highly  
conductive nanoparticle-  
enhanced HDPE.



## Introduction

Ground coupled heat pump systems (GCHP), made of a ground heat exchanger (GHE) and a heat pump unit, are recognized as an efficient and environmentally friendly technology to heat and cool residential and commercial buildings.

Borehole thermal resistance, which is the ability of the GHE to resist heat transfer, is one of the important parameters considered in the design of such system to determine the required heat exchanger length. Selecting appropriate materials and pipe configuration to optimize the borehole thermal resistance can help to decrease the borehole length (Raymond *et al.*, 2015). Versaprofiles has consequently developed a thermally enhanced pipe available in single U, double U and coaxial pipe configurations to reduce the borehole thermal resistance (Raymond, 2013).

This GEOPERFORMX® V2 pipe is charged with nanoparticles increasing the thermal conductivity of the polyethylene matrix by 75% when compared to a conventional HDPE pipe.

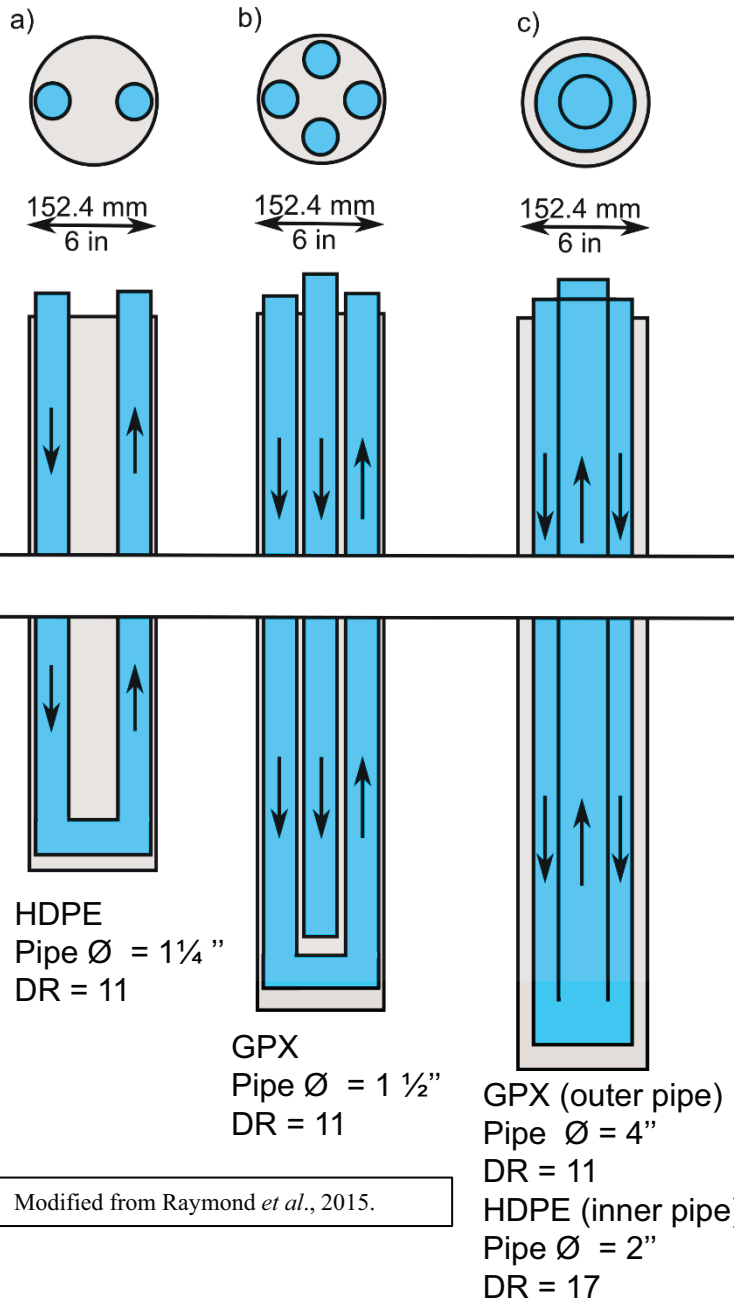

Modified from Raymond *et al.*, 2015.



HDPE  
Pipe  $\text{\O} = \frac{3}{4}$ "  
Central core:  
Pipe  $\text{\O} = 2$ "  
DR = 13.5

<http://www.agreenability.com>

## Objective

At the Blake Group facility located in East Windsor, Connecticut, a GCHP system is used to heat and cool its installation. The GHEs consist of four different closed loops with distinct configurations, three being unconventional:

- Ordinary single U-bend (a);
- Double U-bend (b);
- Coaxial (c);
- Twister quad U-tube (d).

The double U-bend and the outer tube of the coaxial GHE are made of GEOPERFORMX<sup>®</sup> V2 pipes (GPX), with thermal conductivity of  $0.4 \text{ BTU hr}^{-1} \text{ ft}^{-1} \text{ }^{\circ}\text{F}^{-1}$ . The single U-bend and inner tube of the coaxial GHE are made of high-density polyethylene (HDPE, PE4710), with a thermal conductivity of  $0.23 \text{ BTU hr}^{-1} \text{ ft}^{-1} \text{ }^{\circ}\text{F}^{-1}$ . The twister GHE encloses four U-bend made of HDPE (PE4710) pipe twisted around a central core pipe.

The performance of such GHE has rarely been inferred *in situ* in operating systems, although it can be determined analytically based on design criteria. The **objective** of this project was, therefore, to evaluate the *in situ* borehole thermal resistance from operating conditions and demonstrate potential bore length reduction according to inferred performances.

## Methodology—Heat extraction tests

Heat extraction tests including three steps were conducted in the four GHE to evaluate their *in situ* performances:

- 1. Initial circulation:** the tested GHE is isolated from the system and water is circulated without heat extraction or injection to determine the initial temperature of the ground;
- 2. Heat extraction:** the full-building loads are transferred to the tested GHE to evaluate its performance under the peak conditions and determine the *in situ* borehole thermal resistance;
- 3. Thermal recovery:** building loads are redirected to the other three GHEs and water is kept circulating in the tested GHE to monitor the thermal recovery and determine the ground thermal conductivity.

The heat carrier fluid circulating in the system is a mix of water and propylene glycol with a concentration of 12 vol.%.

The filling material of the boreholes is a thermally enhanced grout made of bentonite and graphite with a thermal conductivity of 1.2 BTU hr<sup>-1</sup> ft<sup>-1</sup> °F<sup>-1</sup>.

Steps of the heat extraction tests

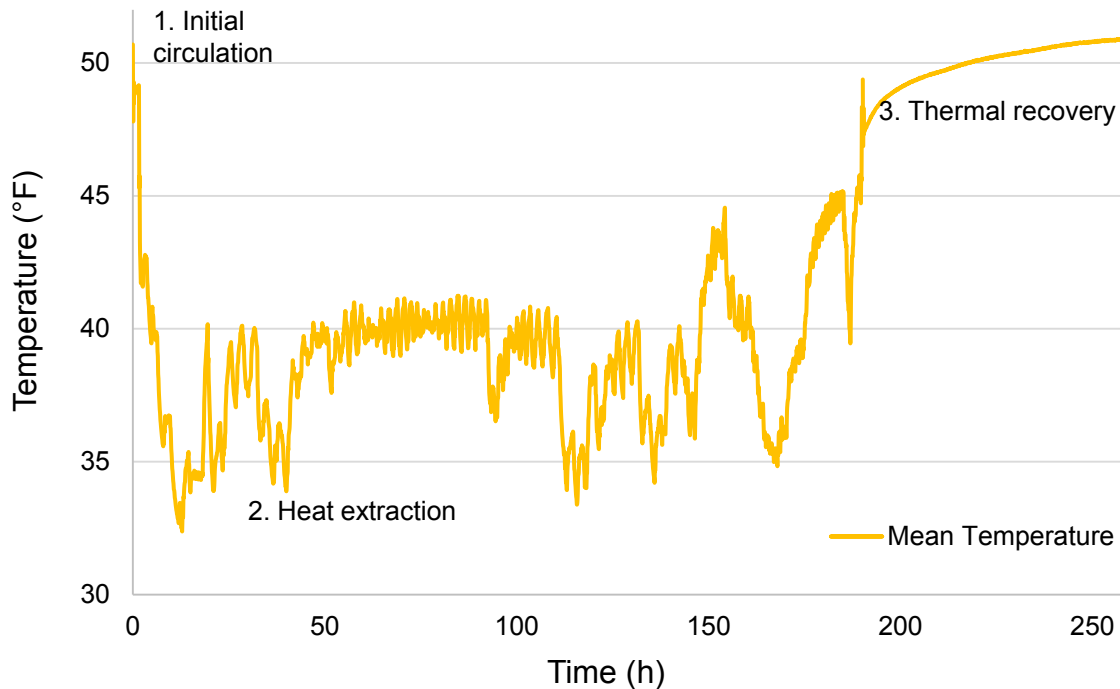

**Fluid type:** Propylene Glycol/Water

**Fluid concentration:** 12 %      **Average temperature at peaks conditions:** 68 ° F

Freezing Point	Density	Volumetric Heat Capacity	Conductivity	Viscosity
° F	lb ft <sup>-3</sup>	Btu ° F <sup>-1</sup> ft <sup>-3</sup>	BTU hr <sup>-1</sup> ft <sup>-1</sup> ° F <sup>-1</sup>	lb m ft <sup>-1</sup> h <sup>-1</sup>
23.03	63.24	60.8	0.305	3.85

Fluid properties from GLHEPro 5.0

## Main Loop

P L HP HRV ⚙️

Mode Hybrid Valve Control Normal Mode Solar Collection Disable

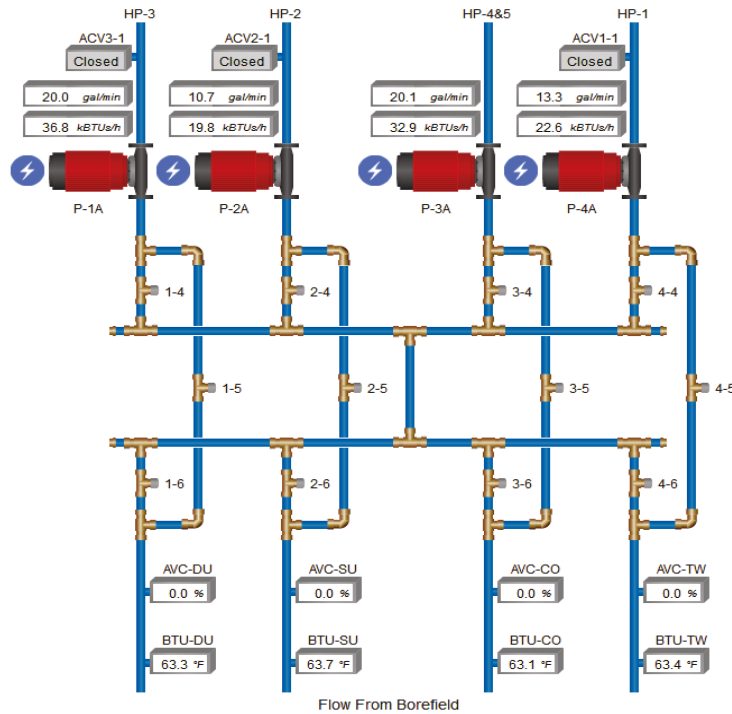

<https://www.deos-controls.com/programmable-controllers/openview/>



<http://www.onicon.com/System40.html>

## GCHP system monitoring

During the test, the water temperature at the inlet and outlet of the GHE and the flow rate are measured every 5 minutes. The Onicon BTU – meters installed at the head of each GHE were used for that purpose. This meter measures temperature with an accuracy of  $\pm 0.18$  °F and flow rate with an accuracy of 1%. Openview, an online interface allowing to monitor the system and to download the recorded data in real time, was used to monitor the tests.

Heat extraction rate at the three steps of the tests

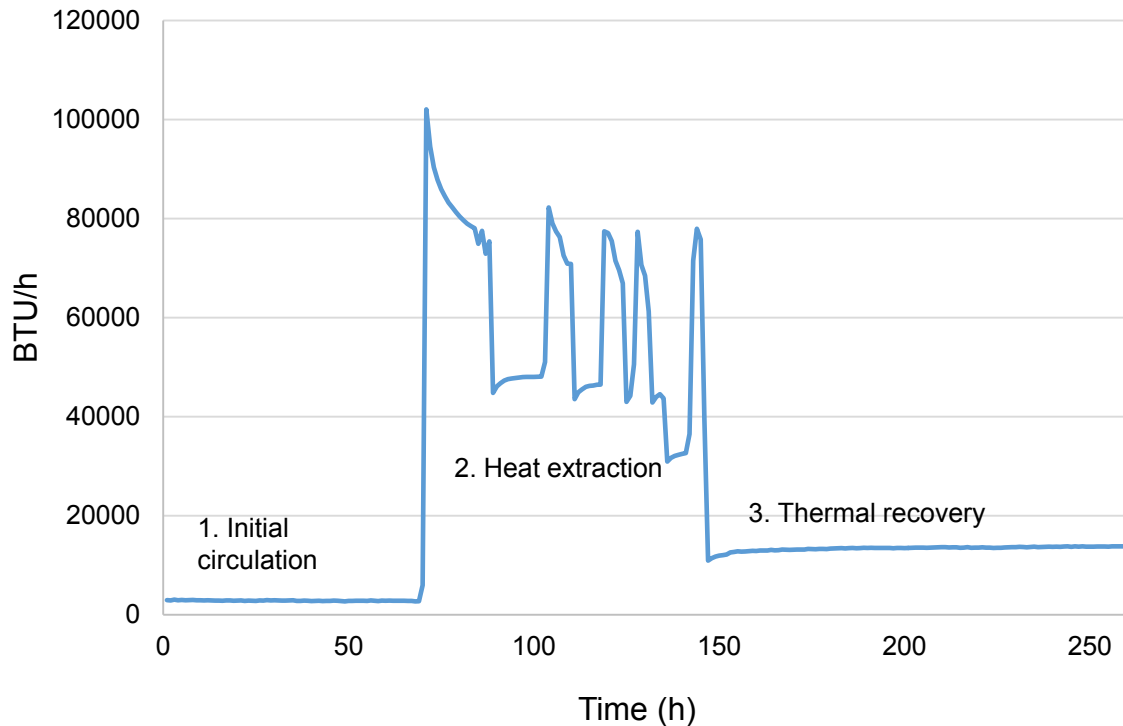

### Calculation of the heat extraction rate

The heat extraction rates  $q$  (BTU h<sup>-1</sup>) imposed to the GHE during each test was calculated hourly from the measured flow rate (ft<sup>3</sup> min<sup>-1</sup>) and the fluid temperature (°F) at the inlet and outlet of the GHE:

$$q = q' (T_{f,i} - T_{f,o}) \rho_f c_f$$

where  $q'$  is the flow rate (ft<sup>3</sup> min<sup>-1</sup>),  $\rho_f$  (lb ft<sup>-3</sup>) is the fluid density and  $c_f$  is the volumetric heat capacity of the fluid (Btu ft<sup>-3</sup> °F<sup>-1</sup>).

The heat extraction rate during the three steps of each test was used to perform an hourly simulation with GLHEPro, where the inlet and outlet temperatures at each time step are calculated. The simulated temperature was manually matched to the observed temperature to infer the initial ground temperature, the *in situ* borehole thermal resistance and the ground thermal conductivity.

GLHEPro - Twin\_Loop\_V3

File Loads Units Action Help Register

Vertical BH Horizontal GHE FPFLS BH

### Borehole Parameters

Active Borehole Depth :  ft

Borehole Diameter :  in

Borehole Thermal Resistance :  °F/(Btu/(hr·ft))

Borehole Spacing :  ft

Borehole Geometry : SINGLE CONFIGURATION 1 : single

### Ground Parameters

Soil type currently entered : Average Rock

Thermal Conductivity of the ground :  Btu/(hr·ft·°F)

Volumetric heat capacity of the ground :  Btu/(°F·ft³)

Average Annual Ground Temperature : 57 °F

Temperature Profile Location : Unspecified, Unspecified

### Fluid Parameters

Total flow rate for entire system :  gal/min

Fluid Type: Propylene Glycol / Water

Fluid Concentration: 15% Average Temperature at Peak Conditions: 68°F

	Freezing Point	Density	Volumetric Heat Capacity	Conductivity	Viscosity
▶	°F	lb/ft³	Btu/(°F·ft³)	Btu/(hr·ft·°F)	lbm/(ft·h)
	20.99	63.44	60.63	0.296	4.33422

### Heat Pump

Heat Pump Selected : ClimateMaster : TS024\_ECM\_MOTOR@6GPM\_610CFM

GLHEPro vertical ground heat exchanger dialog box (GLHEPro 5.0)

## Temperature simulation

Known variables:

- Borehole configuration;
- Pipes and grout properties;
- Flow rate;
- Hourly loads.

Unknown variables:

- Initial ground temperature;
- *In situ* borehole thermal resistance;
- Ground thermal conductivity.

The ground temperature was additionally constrained according to the site location although it had to be adjusted to reproduce the temperature observed in the first step of the tests. This manipulation is necessary because the tests are performed in an operational system and the ground temperature before the tests is already disturbed.

## Borehole thermal resistance and ground thermal conductivity

The borehole thermal resistance was initially calculated with GLHEPro based on the borehole configuration and the ground, grout and fluid properties. The Multipole method (Claesson and Hellström, 2011; Bennett *et al.*, 1987) is used to calculate the local borehole thermal resistance in GLHEPro. The Multipole method is an analytical solution for conductive heat transfer between any number of pipes and the surrounding ground (Spitler *et al.*, 2016). An initial ground thermal conductivity was additionally defined to perform a first hourly simulation.

The simulated temperature was compared to the observed temperature and the least square difference is computed for all the duration of each test. The ground thermal conductivity was gradually varied to reproduce the observed temperature. Finally, the borehole thermal resistance was manually varied to reduce the least square difference between the observed and calculated temperatures.

The estimated thermal conductivity and borehole thermal resistance were used to size GHCP for four different buildings located in different climate zones.

**G-Function and Borehole Resistance Calculator**

U-Tube Double U-Tube Concentric Standing Column Well

**Borehole Specification**

Borehole Diameter (d): 6 in

Shank Spacing (s): 1.3 in

U-Tube Inside Diameter (D1): 1.74 in

U-Tube Outside Diameter (D2): 2.1 in

Volumetric Flow Rate/borehole: 11.27 gal/min

Fluid Factor: 1 Unitless (multiply fluid in the system by this amount)

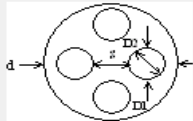

**Borehole Fill**

Grout  Groundwater

**Volumetric Heat Capacities**

Soil: 30.85 Btu/(°F·ft³)

Grout: 50.696 Btu/(°F·ft³)

Pipe: 23.007 Btu/(°F·ft³)

**Thermal Conductivities**

Soil: 1.7 Btu/(hr·ft·°F)

Grout: 1.2 Btu/(hr·ft·°F)

Pipe: 0.23 Btu/(hr·ft·°F)

**Options for specifying the fluid convection coefficient**

Entered Value  
Convection Coefficient: 133.41 Btu/(hr·ft²·°F)  
Reynolds Number: N/A

Calculated Value  
Fluid Type: Propylene Glycol / Water  
Fluid Concentration: 12.5%  
Average Temperature at Peak Conditions: 68°F

	Freezing Point	Density	Volumetric Heat Capacity	Conductivity	Viscosity
	°F	lb/ft³	Btu/(°F·ft³)	Btu/(hr·ft·°F)	lbm/(ft·h)
	22.69	63.27	60.78	0.304	3.92947

**Short Circuiting Effects**

Short Circuiting Effects

Model Type:  Uniform wall temperature  Uniform heat flux  Mean

**G-Function Calculations**

Borehole Resistance: 0.0909 °F/(Btu/(hr·ft))

## Pipes thermal conductivity measurements

A thermal conductivity scanner (TCS) was used to measure the thermal conductivity of pipe samples. This instrument has a moving optical head with an infrared heat source and temperature sensors allowing to scan thermal properties along the sample (Jorand *et al.*, 2013). The range of thermal conductivity evaluation is  $0.2$  to  $25 \text{ W m}^{-1} \text{ K}^{-1}$  with an accuracy of 3%.

The thermal conductivity is measured along a scan line that has been painted with black enamel to ensure proper infrared absorption to heat the sample (Raymond *et al.*, 2017).

When cylindrical samples with a diameter inferior to 80 mm, it is necessary to correct the measurement. Thermal conductivity measures in cylindrical samples are 6% less than thermal conductivity measure in a flat surface (Popov *et al.*, 2003). Then, a correction needs to be applied to the measured thermal conductivity.

The power of the heat source was set a 15% (10.6 W) to create a temperature difference of approximately  $3 \text{ }^{\circ}\text{C}$ .

HDPE and GPX pipe samples with longitudes between 29 and 45 cm were used for the analysis.

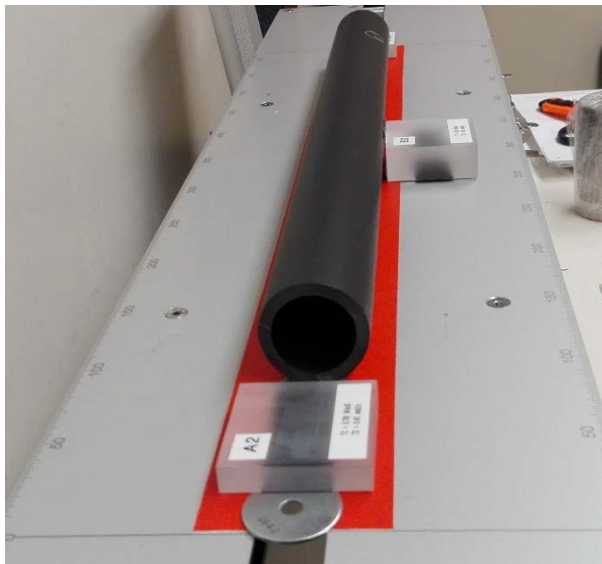

## Single U-bend

### Borehole and pipe specification

Active borehole depth:

$$L_{bh} = 495 \text{ ft (150.9 m)}$$

Pipe specifications:

HDPE

$$\varnothing = 1\frac{1}{4} \text{ ''}$$

DR = 11

$$\lambda_p = 0.23 \text{ BTU hr}^{-1} \text{ ft}^{-1} \text{ }^\circ\text{F}^{-1} \text{ (0.4 W m}^{-1} \text{ K}^{-1}\text{)}$$

### Results

Flow rate

$$10.7 \text{ gal min}^{-1} \text{ (0.67 L s}^{-1}\text{)}$$

Initial simulated temperature:

$$T_{is} = 49.2 \text{ }^\circ\text{F}$$

GLHEPro borehole thermal resistance:

$$R_b = 0.169 \text{ ft }^\circ\text{F hr BTU}^{-1} \text{ (0.98 m K W}^{-1}\text{)}$$

*In situ* borehole thermal resistance:

$$R_b = 0.165 \text{ ft }^\circ\text{F hr BTU}^{-1} \text{ (0.95 m K W}^{-1}\text{)}$$

Ground thermal conductivity:

$$\lambda = 1.1 \text{ BTU hr}^{-1} \text{ ft}^{-1} \text{ }^\circ\text{F}^{-1} \text{ (1.9 W m}^{-1} \text{ K}^{-1}\text{)}$$

Sum of square residuals: **93.1**

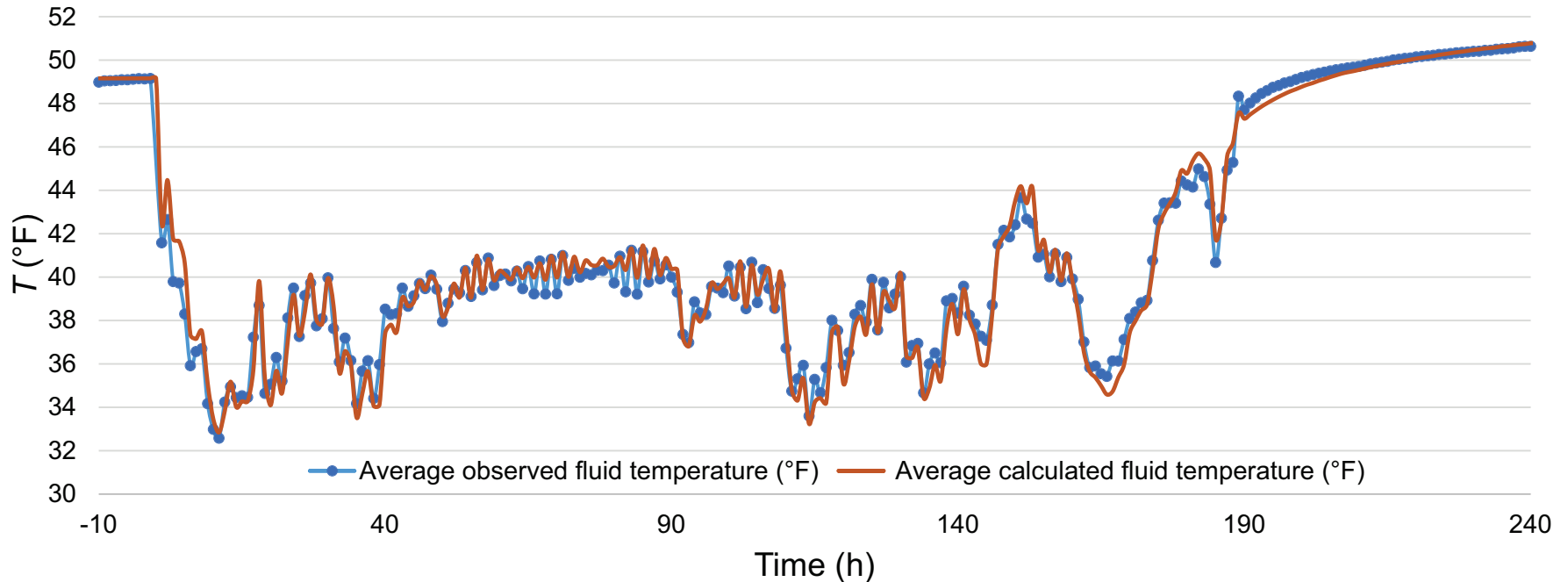

## Double U-bend

### Borehole and pipe specification

Active borehole depth:

$$L_{bh} = 877 \text{ ft (267.3 m)}$$

Pipe specifications:

Gpx

$$\varnothing = 1\frac{1}{2}''$$

DR = 11

$$\lambda_p = 0.4 \text{ BTU hr}^{-1} \text{ ft}^{-1} \text{ } ^\circ\text{F}^{-1} \text{ (0.7 W m}^{-1} \text{ K}^{-1}\text{)}$$

### Results

Flow rate

$$20.5 \text{ gal min}^{-1} \text{ (1.29 L s}^{-1}\text{)}$$

Initial temperature:

$$T_{is} = 51.94 \text{ } ^\circ\text{F}$$

GLHEPro borehole thermal resistance:

$$R_b = 0.067 \text{ ft } ^\circ\text{F hr BTU}^{-1} \text{ (0.039 m K W}^{-1}\text{)}$$

*In situ* borehole thermal resistance:

$$R_b = 0.07 \text{ ft } ^\circ\text{F hr BTU}^{-1} \text{ (0.040 m K W}^{-1}\text{)}$$

Ground thermal conductivity:

$$\lambda_g = 1.2 \text{ BTU hr}^{-1} \text{ ft}^{-1} \text{ } ^\circ\text{F}^{-1} \text{ (2.25 W m}^{-1} \text{ K}^{-1}\text{)}$$

Sum of square residuals: **30.5**

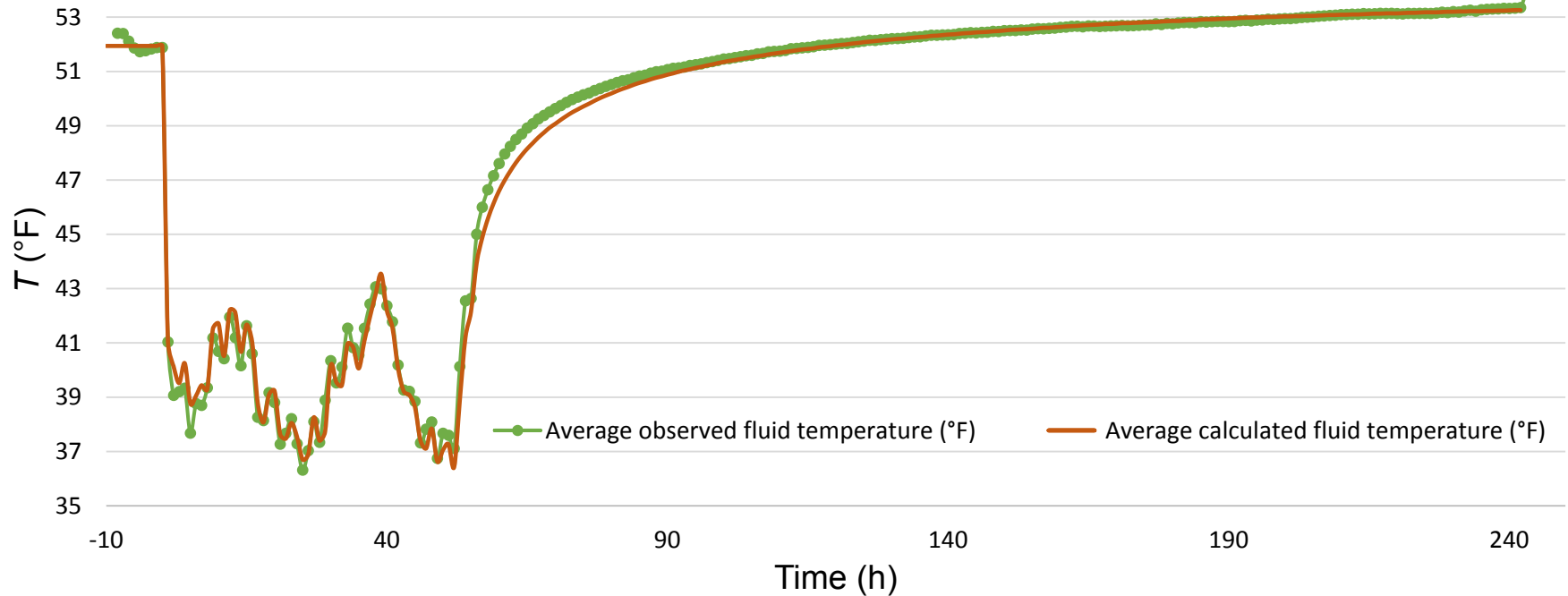

## Coaxial test 1: lower flow rate

### Borehole and pipe specification

Active borehole depth:  
 $L_{bh} = 1054 \text{ ft (321.3 m)}$

Pipe specifications:

#### Inner pipe

HDPE,  $\varnothing = 2 \text{ ''}$

DR = 11

$\lambda_p = 0.23 \text{ BTU hr}^{-1} \text{ ft}^{-1} \text{ }^\circ\text{F}^{-1} (0.4 \text{ W m}^{-1} \text{ K}^{-1})$

#### Outer pipe

GPX,  $\varnothing = 4 \text{ ''}$

DR = 17

$\lambda_p = 0.4 \text{ BTU hr}^{-1} \text{ ft}^{-1} \text{ }^\circ\text{F}^{-1} (0.7 \text{ W m}^{-1} \text{ K}^{-1})$

## Results

Flow rate

**$21.5 \text{ gal min}^{-1} (1.30 \text{ L s}^{-1})$**

Initial simulated temperature:

**$T_{is} = 55.4 \text{ }^\circ\text{F}$**

GLHEPro borehole thermal resistance:

**$R_b = 0.1302 \text{ ft }^\circ\text{F hr BTU}^{-1} (0.075 \text{ m K W}^{-1})$**

*In situ* borehole thermal resistance:

**$R_b = 0.155 \text{ ft }^\circ\text{F hr BTU}^{-1} (0.090 \text{ m K W}^{-1})$**

Ground thermal conductivity:

**$\lambda = 1.4 \text{ BTU hr}^{-1} \text{ ft}^{-1} \text{ }^\circ\text{F}^{-1} (2.4 \text{ W m}^{-1} \text{ K}^{-1})$**

Sum of square residuals: **49.3**

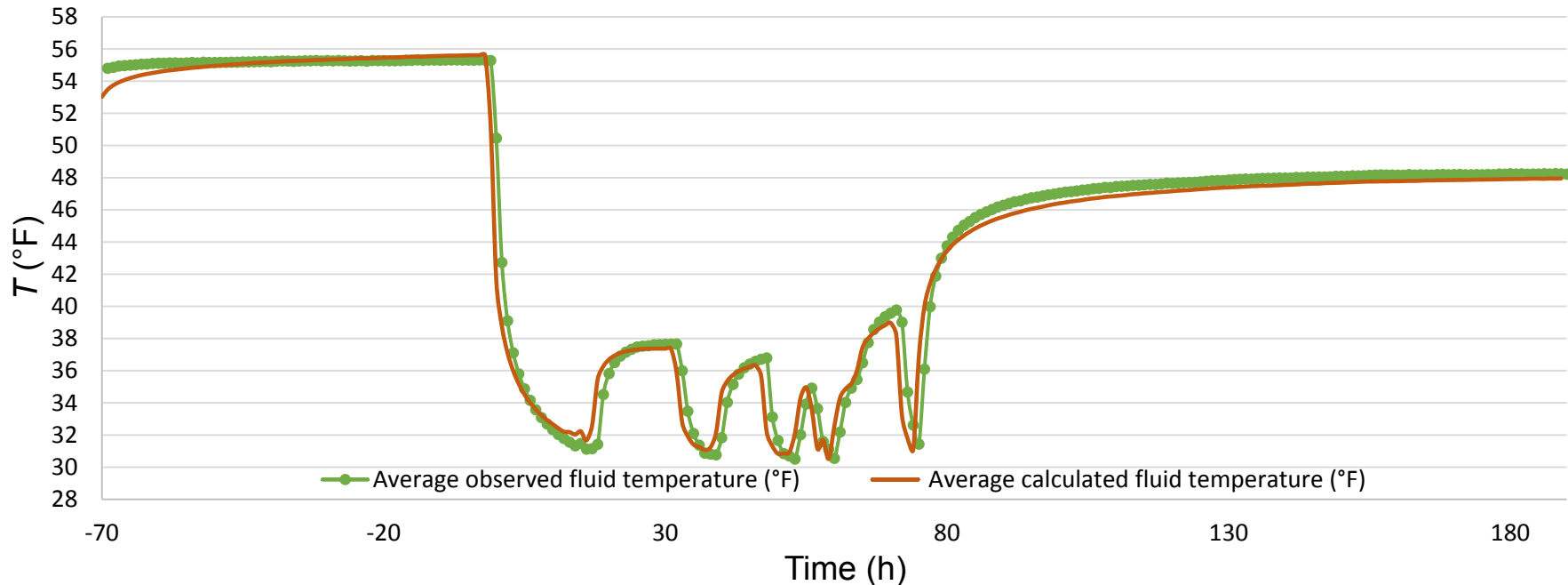

## Coaxial test 2: higher flow rate

### Borehole and pipe specification

Active borehole depth:  
 $L_{bh} = 1054 \text{ ft (321.3 m)}$

Pipe specifications:

#### Inner pipe

HDPE,  $\varnothing = 2 \text{ ''}$

DR = 11

$\lambda_p = 0.23 \text{ BTU hr}^{-1} \text{ ft}^{-1} \text{ }^\circ\text{F}^{-1} \text{ (} 0.4 \text{ W m}^{-1} \text{ K}^{-1}\text{)}$

#### Outer pipe

GPX,  $\varnothing = 4 \text{ ''}$

DR = 17

$\lambda_p = 0.4 \text{ BTU hr}^{-1} \text{ ft}^{-1} \text{ }^\circ\text{F}^{-1} \text{ (} 0.7 \text{ W m}^{-1} \text{ K}^{-1}\text{)}$

### Results

Flow rate

**24.2 gal min<sup>-1</sup> (1.36 L s<sup>-1</sup>)**

Initial simulated temperature:

**$T_{is} = 50.6 \text{ }^\circ\text{F}$**

GLHEPro borehole thermal resistance:

**$R_b = 0.124 \text{ ft }^\circ\text{F hr BTU}^{-1} \text{ (} 0.072 \text{ m K W}^{-1}\text{)}$**

*In situ* borehole thermal resistance:

**$R_b = 0.13 \text{ ft }^\circ\text{F hr BTU}^{-1} \text{ (} 0.078 \text{ m K W}^{-1}\text{)}$**

Ground thermal conductivity:

**$\lambda = 1.4 \text{ BTU hr}^{-1} \text{ ft}^{-1} \text{ }^\circ\text{F}^{-1} \text{ (} 2.4 \text{ W m}^{-1} \text{ K}^{-1}\text{)}$**

Sum of square residuals: **92**

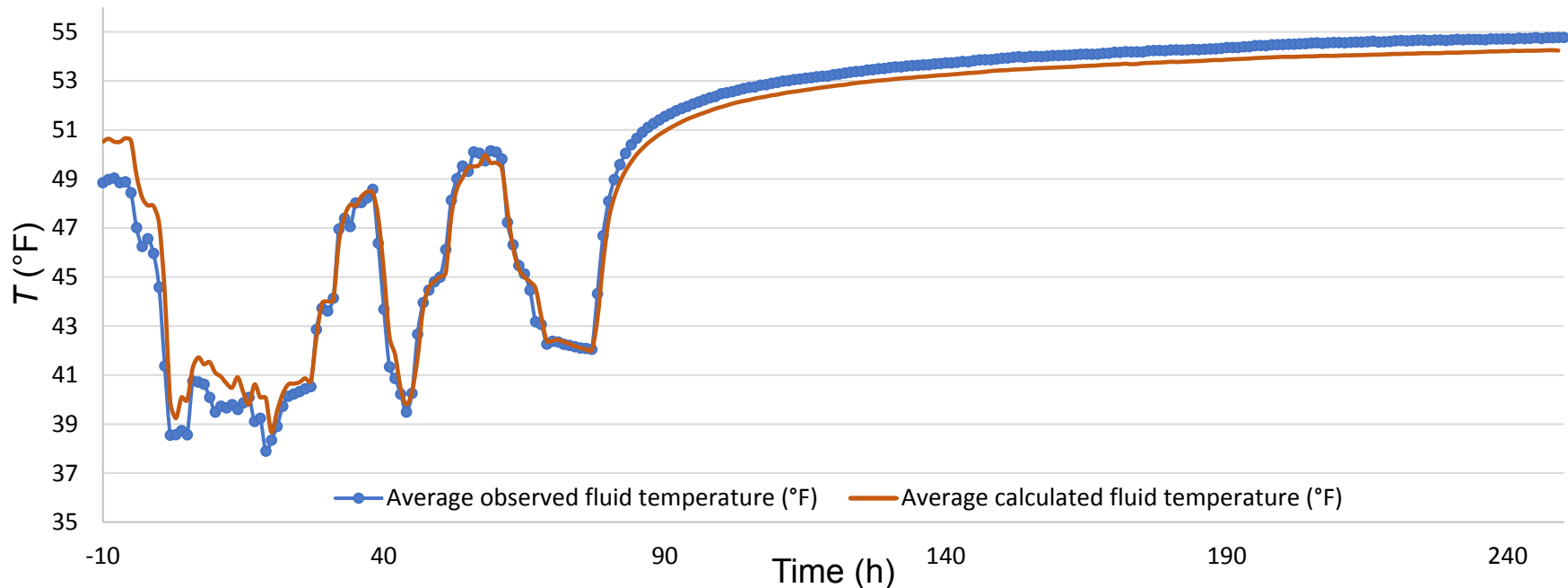

## Twister

### Borehole and pipe specification

Active borehole depth (twisted):

$$L_{bh} = 446.3 \text{ ft (136 m)}$$

Borehole depth:

$$L_b = 441 \text{ (134.4 m)}$$

Pipe specifications:

HDPE,  $\varnothing = \frac{3}{4}$ "

DR = 13.5

$$\lambda_p = 0.23 \text{ BTU hr}^{-1} \text{ ft}^{-1} \text{ }^\circ\text{F}^{-1} \text{ (0.4 W m}^{-1} \text{ K}^{-1}\text{)}$$

The twister configuration is not available in GLHEPro. The simulations were performed with a double U-bend configuration with pipe diameter = 1 1/2" to represent the volume of the 8 pipes and defined an active borehole length 1.2% higher than the borehole depth to take into account the additional length of the twisted pipes.

## Results

Flow rate

$$11.27 \text{ gal min}^{-1} \text{ (0.71 L s}^{-1}\text{)}$$

Initial simulated temperature:

$$T_{is} = 46.3 \text{ }^\circ\text{F}$$

GLHEPro borehole thermal resistance:

$$R_b = 0.106 \text{ ft }^\circ\text{F hr BTU}^{-1} \text{ (0.061 m K W}^{-1}\text{)}$$

*In situ* borehole thermal resistance:

$$R_b = 0.094 \text{ ft }^\circ\text{F hr BTU}^{-1} \text{ (0.054 m K W}^{-1}\text{)}$$

Ground thermal conductivity:

$$\lambda = 1.6 \text{ BTU hr}^{-1} \text{ ft}^{-1} \text{ }^\circ\text{F}^{-1} \text{ (2.8 W m}^{-1} \text{ K}^{-1}\text{)}$$

Sum of square residuals: **93.3**

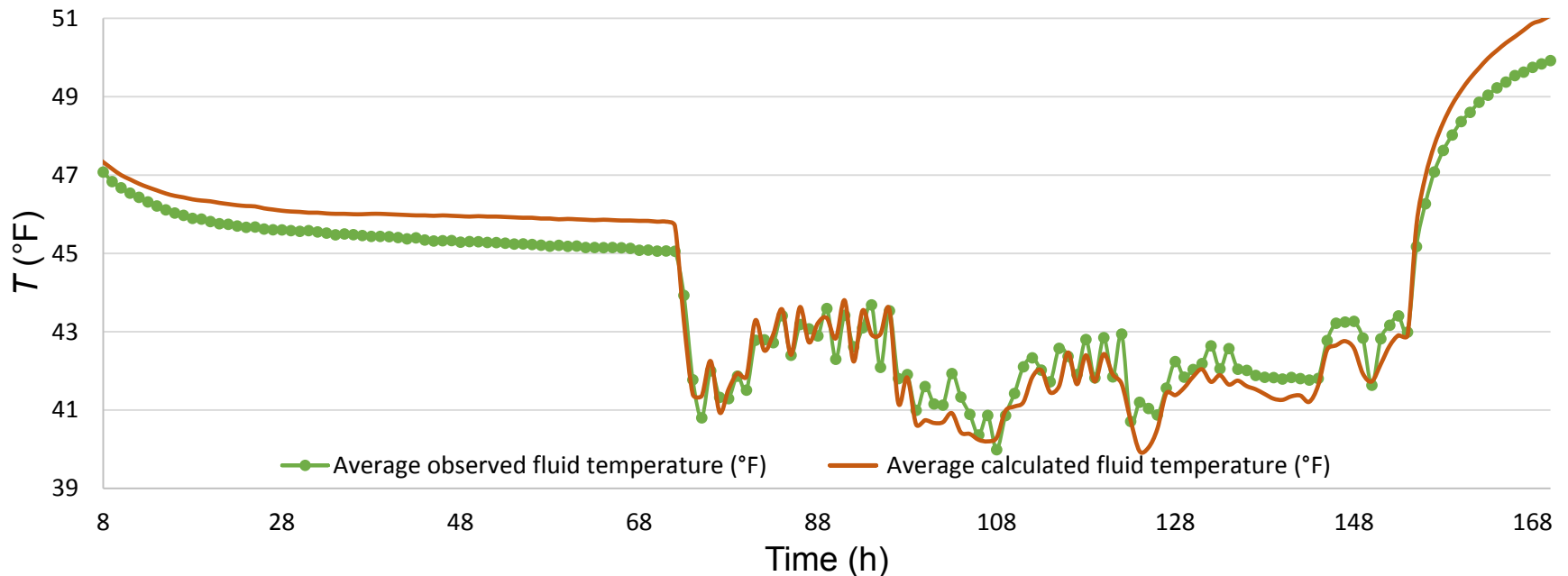

## Estimated borehole thermal resistance

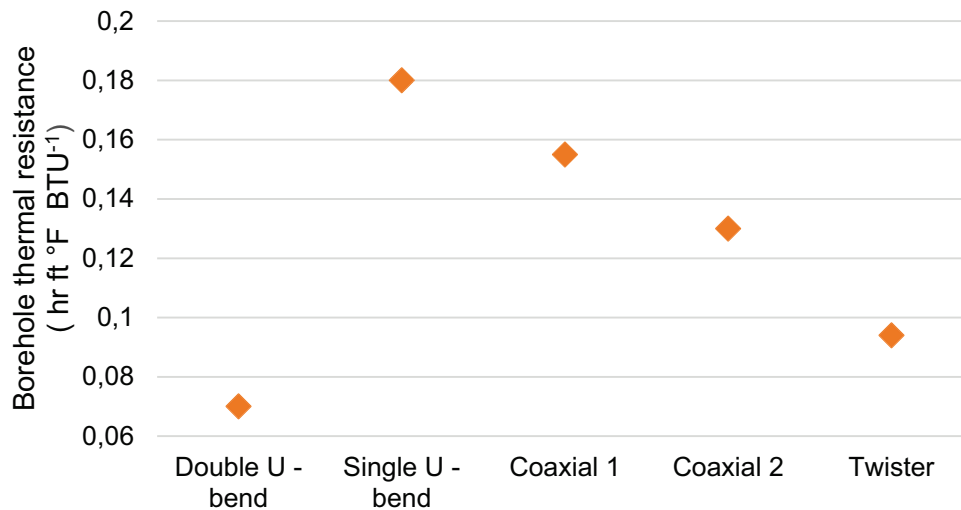

	Borehole thermal resistance	
	hr ft °F BTU <sup>-1</sup>	mK W <sup>-1</sup>
<b>Double U – bend</b>		
Analytical (GLHEPro)	0.067	0.039
<i>In situ</i>	0.07	0.040
Difference		<b>-4.2</b>
<b>Single U - bend</b>		
Analytical (GLHEPro)	0.169	0.097
<i>In situ</i>	0.18	0.10
Difference		<b>-6.6</b>
<b>Coaxial test 1</b>		
Analytical (GLHEPro)	0.130	0.075
<i>In situ</i>	0.155	0.090
Difference		<b>-19.0</b>
<b>Coaxial test 2 (higher flow rate)</b>		
Analytical (GLHEPro)	0.124	0.072
<i>In situ</i>	0.13	0.078
Difference		<b>-4.4</b>
<b>Twister</b>		
Analytical (GLHEPro)	0.106	0.061
<i>In situ</i>	0.094	0.054
Difference		<b>11.0</b>

## Borehole thermal resistance

The difference between the *in situ* and the analytical borehole thermal resistance varied between -19 and 11%. The *in situ* borehole thermal resistances were always higher than the value provide by GLHEPro, with the exception of the twister GHE.

The GHE configuration with the lowest thermal resistance is the double U–bend made with the thermal enhanced pipe (GPX 1½“). The single U-bend, with a 1¼“ HDPE pipe has the higher borehole thermal resistance. The twister GHE, with a HDPE pipe (PE4710) had the second-lowest thermal resistance.

Two test with different flow rates were performed for the coaxial GHE. The increase of the flow rate in the test 2 resulted in a reduction of 13% of the borehole thermal resistance compared to the test 1.

The coaxial GHE was expected to have a lower borehole thermal resistance. However, during the construction there was an issue with the grout placement. Graphite and bentonite could locally be separated leaving the grout thermal conductivity questionable with spatial variations.

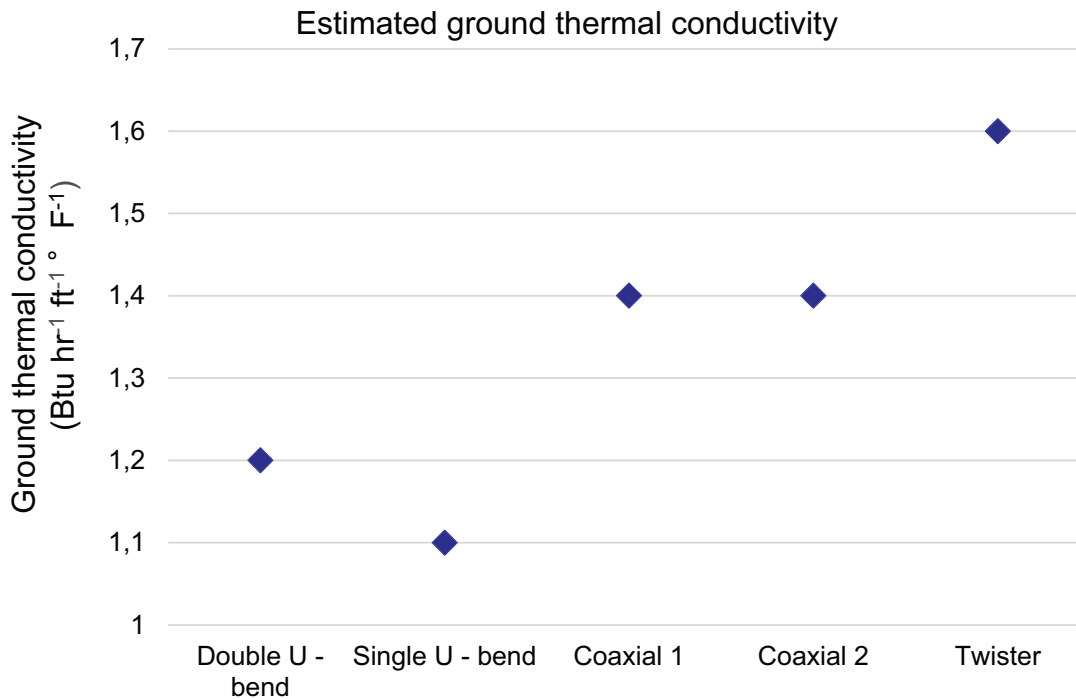

## Ground thermal conductivity

The thermal conductivity varied between 1.1 and 1.6 BTU hr<sup>-1</sup> ft<sup>-1</sup> °F among the boreholes. The lower ground thermal conductivity identified at the site was 1.1 BTU hr<sup>-1</sup> ft<sup>-1</sup> °F. This value was estimated at the single U-bend GHE having a depth of 495 ft. A higher thermal conductivity was estimated at the coaxial GHE, which is the deeper borehole (1054 ft). This increase in bulk thermal conductivity suggests that the GHE intercept ground layers with a higher thermal conductivity at depth or zones with groundwater flow.

During the drilling the same sandstone were observed in the four boreholes at different depths. Thus, the variation in the thermal conductivity is likely due to groundwater flows. The highest water flow rate was observed with fluid circulation during drilling at the twister borehole and the lowest at the single U-bend. These observations are coherent with the estimated thermal conductivity.

## Buildings Loads

The annual loads of four different buildings located in distinct climatic zones were used to design GCHP systems with four GHE configurations tested and the *in situ* borehole thermal resistance. The building loads for the large office, the hospital and the large hotel were taken from the database of the Office of Energy Efficiency & Renewable Energy (EERE). The loads for the high school were provided by Versaprofiles.

The peak load duration tool Available in GLHEPro V.5 was used to estimate the peak duration and determine the monthly load profiles.

The maximal fluid temperature was defined 17 °C above the average annual ground temperature of the climate zone and the minimum 6 °C below the average annual ground temperature as recommended in ASHRAE (2011) guidelines.

The grout thermal conductivity was assumed to be 1.2 BTU hr<sup>-1</sup> ft<sup>-1</sup> °F<sup>-1</sup>. The selected space between the boreholes was 15 ft.

The ground thermal conductivity was set as 1.23 BTU hr<sup>-1</sup> ft<sup>-1</sup> °F<sup>-1</sup>, representing the average thermal conductivity estimated at the single U-bend, double U-bend and the coaxial GHEs. The value estimated at the twister loop was not considered because it seems to be affected by the groundwater flow and this phenomenon was not observed at the other boreholes.

Large Office  
Hartford, CT  
Climate zone: 5A

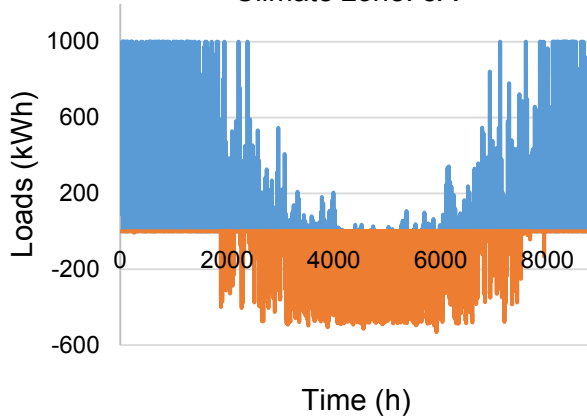

High school  
Bridgehampton, NY  
Climate zone: 4A

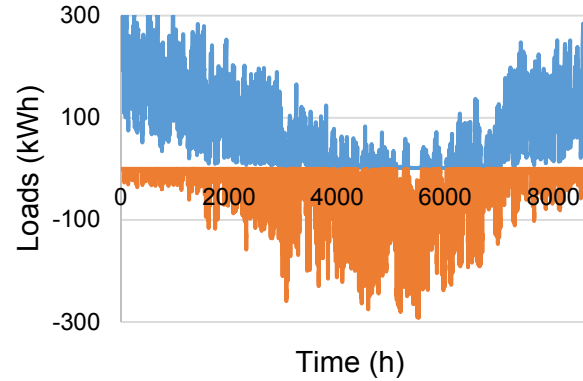

Hospital  
Denver, CO  
Climate zone: 5B

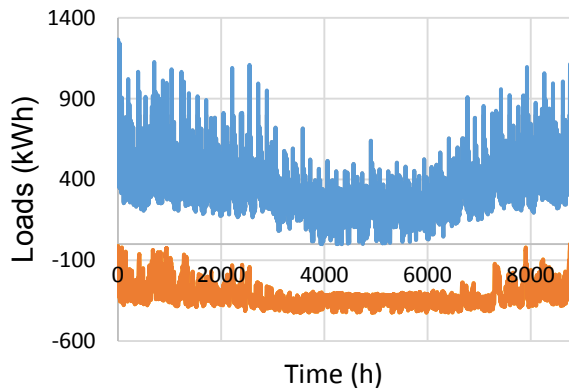

Large hotel  
Bangor, ME  
Climate zone: 6A

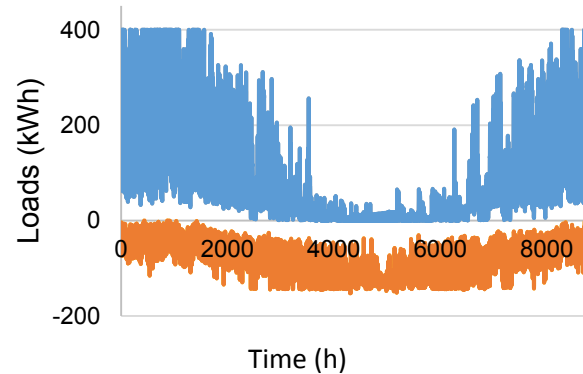

— Heating  
— Cooling

### Sizing results with GLHEPro

Systems parameters	Single	Double	Coaxial		Twister
	U-bend	U-bend	Inner	Outer	
Pipe thermal conductivity (Btu hr <sup>-1</sup> ft <sup>-1</sup> ° F <sup>-1</sup> )	0.23	0.4	0.23	0.4	0.23
Pipe size (in)	1.25	1.5	2	4	0.75
<i>In situ</i> borehole thermal resistance (hr ft ° F BTU-1)	0.18	0.07	0.155		0.094

#### Large Office

Number of boreholes (-)	120	75	70	100
Borehole distribution (-)	10 x 12	3 x 25	5 x 14	10 x 10
GHE length (ft)	606	734	922	612
Borehole length (ft)	-	-	-	619
Total GHE length (ft)	72749	55085	64504	61174
<b>GHE length reduction (%)</b>		<b>24</b>	<b>11</b>	<b>16</b>

#### Secondary school

Number of boreholes (-)	96	64	54	75
Borehole distribution (-)	8 x 12	4 x 16	6 x 9	3 x 25
GHE length (ft)	583	716	940	594
Borehole length (ft)	-	-	-	602
Total GHE length (ft)	55935	45832	50758	44579
<b>GHE length reduction (%)</b>		<b>18</b>	<b>9</b>	<b>20</b>

#### Hospital

Number of boreholes (-)	132	96	72	120
Borehole distribution (-)	11 x 12	6 x 16	4 x 18	10 x 12
GHE length (ft)	619	759	940	656
Borehole length (ft)	-	-	-	664
Total GHE length (ft)	81738	72845	67645	78701
<b>GHE length reduction (%)</b>		<b>11</b>	<b>17</b>	<b>5</b>

#### Large hotel

Number of boreholes (-)	56	35	32	45
Borehole distribution (-)	7 x 8	5 x 7	4 x 8	5 x 9
GHE length (ft)	600	762	955	643
Borehole length (ft)	-	-	-	650
Total GHE length (ft)	33600	26660	30567	28919
<b>GHE length reduction (%)</b>		<b>21</b>	<b>9</b>	<b>14</b>

### Sizing calculation results with GLHEPro

GCHP systems were size to cover the cooling and heating building needs using GLHEPro. Length intervals were defined to design each systems according to the typical length used in the industry for each of the GHE configuration:

- Single U-bend: 500 – 700 ft;
- Double U-bend: 700 – 900 ft;
- Coaxial: 900 – 1000 ft;
- Twister: 500 – 700 ft.

The single U-bend GHE was used as a reference case to calculate the relative GHE length reduction in the other cases.

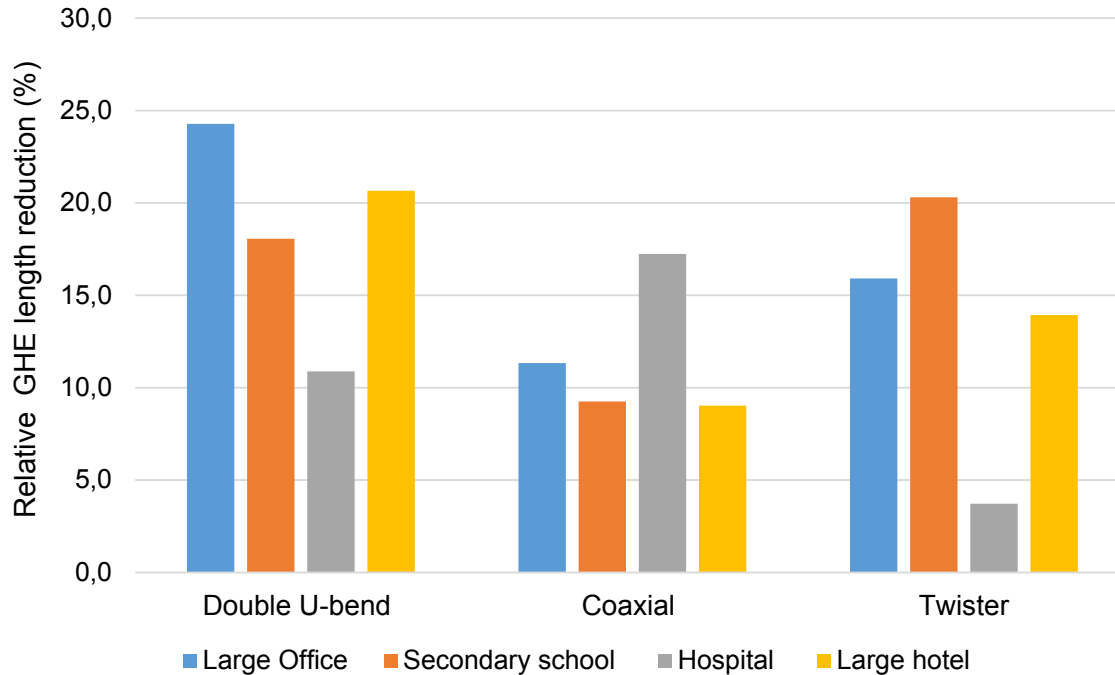

## Sizing calculation results

The average length reductions are:

- Double U-bend 18.5%;
- Coaxial 11.7%;
- Twister 13.5%.

The double U-bend with thermally enhanced pipe provides the maximal length reduction in two of the four cases. It is also the configuration with the lowest borehole thermal resistance.

The climate zone, influencing the average annual ground temperature, and the load profiles are the parameters varying in the sizing calculations. The ground and gout thermal conductivity were kept constant.

The borehole reduction found with the hospital had a different tendency compared with the other building. The coaxial GHE is the most advantageous configuration for this building.

The annual load profile of the hospital is almost constant without significant heating and cooling peaks. This characteristic seems to be easily covered by the coaxial GHE. In future work, increasing the ground temperature with the borehole length could help to assess the performance of this GHE for load profiles without significant heating and cooling peaks. In this building the twister GHE, which has the shallowest depth is the less favorable GHE.

The twister GHE had the highest borehole length reduction for the high school located in a cooling dominant zone. This GHE tends to be installed at shallower depths where the formation temperatures are generally more favorable to heat rejection.

**Pipe type: HDPE**

<b>Heat source power</b>		15%	10.6 W		
<b>Thermal conductivity (W m<sup>-1</sup> K<sup>-1</sup>)</b>					
Sample	Length	Minimal	Maximal	Average	Correction
1	29.8	0.453	0.6	0.495	0.53
2	30.8	0.438	0.554	0.499	0.53
3	43.7	0.479	0.665	0.551	0.59
4	30.3	0.456	0.579	0.519	0.55
5	30.2	0.402	0.503	0.442	0.47
6	43.4	0.403	0.52	0.455	0.48
<b>Average</b>		0.44	0.57	<b>0.49</b>	<b>0.52</b>

**Pipe type: GPX**

<b>Heat source power</b>		15%	10.6 W		
<b>Thermal conductivity (W m<sup>-1</sup> K<sup>-1</sup>)</b>					
Sample	Length	Minimal	Maximal	Average	Correction
1	29.2	0.52	0.75	0.60	0.64
2	33.5	0.51	0.64	0.57	0.61
3	31.4	0.53	0.71	0.62	0.65
4	32.2	0.55	0.73	0.61	0.65
5	31.2	0.52	0.70	0.60	0.64
6	40.7	0.62	0.80	0.69	0.73
<b>Average</b>		0.54	0.72	<b>0.61</b>	<b>0.65</b>

**Pipes thermal conductivity measurements**

The measured thermal conductivity for the conventional pipe was  $0.52 \pm 0.03 \text{ Wm}^{-1}\text{K}^{-1}$ , when the correction for cylinder samples is applied. For the thermally enhanced pipe, the corrected thermal conductivity was  $0.65 \pm 0.03 \text{ Wm}^{-1}\text{K}^{-1}$ .

This value is 6% lower than the  $0.7 \text{ Wm}^{-1}\text{K}^{-1}$  considered as thermal conductivity for the enhanced pipe. However, the maximal values measure with the scanner are similar to the thermal conductivity measured in the past with the needle probe (KD2Pro) on bulk high-density polyethylene samples.

The differences can be related to the measurement method that is specifically designed to measure thermal conductivity in rocks. The thermal conductivity scanner has not been designed to measure thermal conductivity on pipes that are empty, which may explain some of the difficulties in obtaining representative results. The advantage of the optical scanner measurements is to identify possible variation in the pipe thermal conductivity.

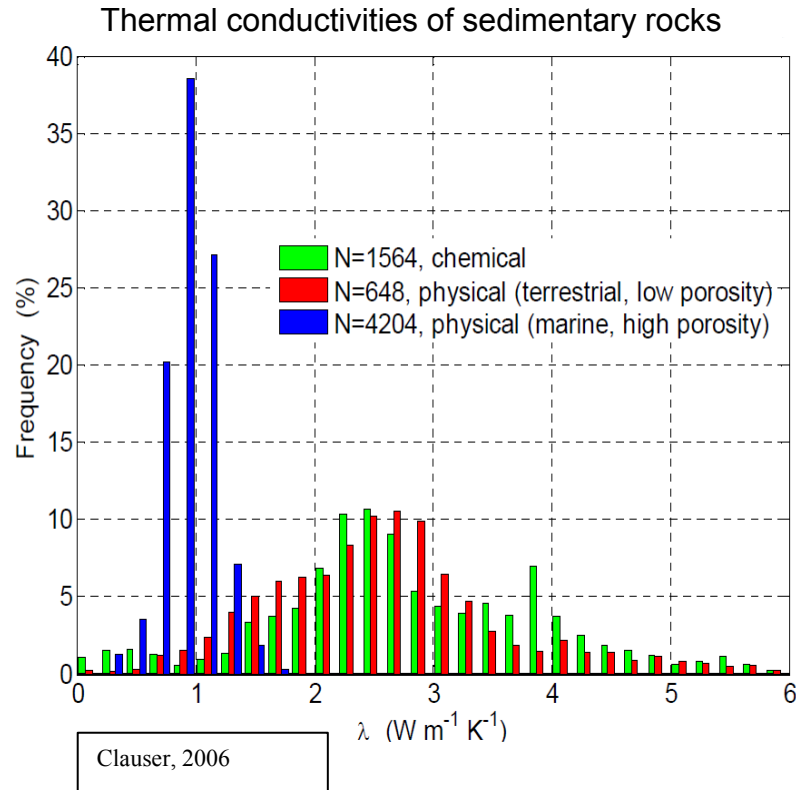

## Discussion

The average thermal conductivity at the experimental site is  $1.34 \text{ BTU hr}^{-1} \text{ ft}^{-1} \text{ }^{\circ}\text{F}^{-1}$  ( $2.3 \text{ W m}^{-1} \text{K}^{-1}$ ). The boreholes were drilled in sedimentary rocks, mainly characterized by red sandstones. The estimated thermal conductivity at the site is in the expected range of values for sedimentary rocks according to Clausner (2006).

The analysis of the heat extraction test in the twister borehole is an approximation of the GHE performance limited by the available GHE configuration in GLHEPro. Agrenability, the company producing the twister GHE, provide a borehole thermal resistance of  $0.071 \text{ hr ft }^{\circ}\text{F BTU}^{-1}$  for a 6" borehole installed with grout of  $1.2 \text{ BTU hr}^{-1} \text{ ft}^{-1} \text{ }^{\circ}\text{F}^{-1}$ . This value is 32.3% lower than the *in situ* estimation. The consideration of the active borehole length instead of the borehole depth could explain this difference. The flow rate is one of the parameters influencing the borehole thermal resistance of the coaxial pipe (Raymond *et al.*, 2015). The results of the test performed in the coaxial GHE show that the increase in the flow rate allows to reduce the borehole thermal resistance. Maintaining a higher flow rate in this borehole can contribute improving its performance.

## **Conclusions**

The double U-bend with the thermally enhanced pipe appears to be the most advantageous configuration to reduce the borehole thermal resistance. The double U-bend is also the configuration providing the higher borehole length reduction when compared to the single U-bend.

The variation of the flow rate in the heat extraction tests shows that the increase in the flow rate had a positive effect in the borehole thermal resistance of the coaxial ground heat exchanger, having interesting heat exchange performances.

However, the borehole length reduction found with the different borehole configurations varied depending on the building type. In future work the influence of the load profiles in the sizing calculation could be studied to evaluate if there is a ground heat exchanger configuration more advantageous according to the building requirements.

The thermal conductivity measurement with the scanner allowed to validate the increase of thermal conductivity of the pipes and contribute to identify possible heterogeneity in the pipe thermal conductivity.

## **Acknowledgment**

This project was supported by the Mitacs Accelerate program. Mitacs, Versaprofiles and Blake Group are acknowledged to fund this research. Professor Jeffrey Spitler at Oklahoma State University is kindly acknowledged for providing a non-commercial license of GLHEPRO to conduct the work presented in this report. Jeff Harrison is acknowledged to carry out the heat extraction test. Mathieu Brousseau, Jean-Francois Lavoie and Jasmin Raymond are acknowledged to support the development of the project.

# References

- ASHRAE, 2011. ASHRAE Handbook - HVAC Applications. Si edition ed., American Society of Heating, Refrigerating and Air-Conditioning Engineers, Atlanta, GA.
- Bennet, J., J. Claesson, and G. Hellström. 1987. Multipole Method to Compute the Conductive Heat Flows to and Between Pipes in a Composite Cylinder, Notes on Heat Transfer 3-1987, Department of Building Technology and Mathematical Physics, University of Lund, Sweden.
- Claesson, J. and G. Hellström. 2011. Multipole method to calculate borehole thermal resistances in a borehole heat exchanger. HVAC&R Research, 17(6):895-911.
- Clauser, C., 2006. Geothermal Energy, In: K. Heinloth (Ed), Landolt-Börnstein, Group VIII: “Advanced Materials and Technologies”, Vol. 3 “Energy Technologies”, Subvol. C “Renewable Energies”, 480 – 595, Springer Verlag, Heidelberg-Berlin.
- Jorand, R., Vogt, C., Marquart, G. and Clauser, C.: Effective thermal conductivity of heterogeneous rocks from laboratory experiments and numerical modeling. J. Geophys. Res. Solid Earth. V. 118 (2013). p. 5225–5235.
- Office of Energy Efficiency & Renewable Energy (EERE). Available at [http://www1.eere.energy.gov/buildings/commercial/ref\\_buildings.html](http://www1.eere.energy.gov/buildings/commercial/ref_buildings.html)
- Popov, Y., Pohl, J., Romushkevich, R., Tertychnyi, V. and Soffel, H., 2003. Geothermal characteristics of the Ries impact structure. Geophysical Journal International, 154(2), pp.355-378.
- Raymond, J., Comeau, F.-A., Malo, M., Blessent, D., & López Sánchez, I. J. (2017). The Geothermal Open Laboratory: a free space to measure thermal and hydraulic properties of geological materials. Paper presented at the IGCP636 Annual Meeting, Santiago de Chile.
- Raymond, J., Mercier, S., & Nguyen, L., 2015. Designing coaxial ground heat exchangers with a thermally enhanced outer pipe. Geothermal Energy, 3(1), 7. doi:10.1186/s40517-015-0027-3
- Raymond, J., 2013. GEOPERFORMX - HDPD pipe with increased thermal conductivity for geothermal applications (pp. 4). Saint-Lazare-de-Bellechasse (QC), Canada: Versaprofiles.
- Spitler, J.D., Marshall, C., Manickam, A., Dharapuram, M., Delahoussaye, R.D., Yeung, K.W.D., Young, R., Bhargava, M., Mokashi, S., Yavuzturk, C., Haider, M., Xu, X., Cullin, J., Dickinson, B., Lee, E., Grundmann, R., 2016. Users’ Guide for GLHEPro 5.0 for Windows. Technical Report. School of Mechanical and Aerospace Engineering. Oklahoma State University, Stillwater, Oklahoma, United States.