



Guide

Work Near Power Lines

2023 Edition

Published on March 31, 2023



Table of contents

General	4
Work near overhead power lines	5
Safety measures – Low voltage (750 volts and under)	6
Measure 1 – Temporary insulation of a service loop or the low-voltage system	6
Safety measures – Medium voltage (more than 750 volts, but less than 44,000 volts)	8
Measure 2 – Temporary insulation of medium-voltage conductors using covers	8
Measure 3 – Moving medium-voltage conductors using temporary H-frames	12
Measure 4 – De-energizing part of the line with or without a bypass	14
Other safety and protection measures	16
Measure 5 – Temporary support of a pole	16
Measure 6 – Securing a site so that a load can be transported under a power line	18
Measure 7 – Standard E.32.1-01 related to municipal public lighting	20
Checking Hydro-Québec's safety measures on your jobsite	22

Work near underground power lines	27
Introduction	28
Preliminary site visit	28
Info-Excavation requests	29
More information	29
Hydro-Québec requests	30
Complying with clearance zones	30
Supporting duct banks	30
Altering duct banks	31
Starting the work	32
Important links	33

General

When conducting work near Hydro-Québec's electrical infrastructure, it's important to consider the safety of everyone on the jobsite.

If you are planning work near power lines, start by consulting our general information sheet (<https://www.hydroquebec.com/data/securite/pdf/general-info-work-near-lines.pdf>) to find out:

- When and how to contact Hydro-Québec
- What Hydro-Québec can do to make the jobsite safe, according to the standards in effect



This guide is divided into two main sections:

1 If there are overhead power lines near the jobsite, the guide lists:

- The different safety measures* Hydro-Québec might need to take

2 If you are planning excavation work at a site that may contain underground power lines, the guide explains:

- How to find out if there is underground infrastructure at the site
- How to contact Hydro-Québec in certain situations
- What precautions you will need to take during the work

* These measures require you to enter into an agreement with Hydro-Québec and sign the *Convention - Interventions à proximité de lignes électriques* (agreement to conduct work near power lines).

Work near overhead power lines

The following pages contain examples of safety measures applied in different situations. These examples are for information purposes only. For specific questions about your jobsite and the measures that will be used there, contact the technician assigned to your file.

Measure 1

Temporary insulation of a service loop or the low-voltage system

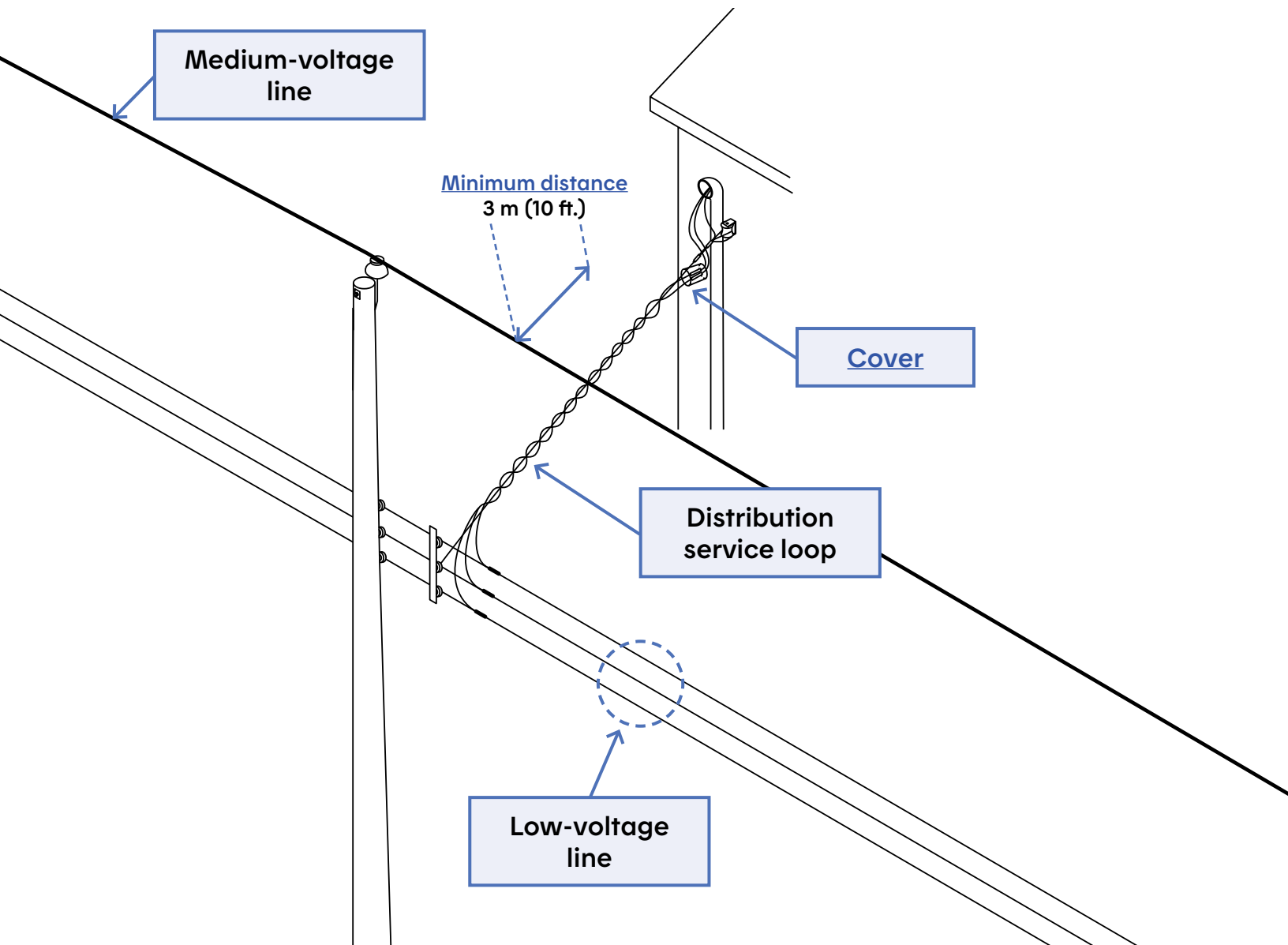

Measure 1

Temporary insulation of a service loop or the low-voltage system

SITUATION

Work to be done near the low-voltage service loop, more than 3 m (10 ft.) from all medium-voltage lines.

HYDRO-QUÉBEC'S SAFETY MEASURES

The Hydro-Québec team will secure the power system by installing [covers](#) on the exposed portions of the service loop or the low-voltage conductors.

Your measures

(WARNINGS)

You must ensure that the scaffolding or any other structures used for the work do not come into contact with the low-voltage conductors. Contact with the live parts of the distributor's service loop or the low-voltage line could lead to electric shock.

CHECKING MEASURES

On a daily basis, you must ensure that:

- The safety measures implemented are compliant with the measures set out in the *Convention – Interventions à proximité de lignes électriques* (agreement to conduct work near power lines).
- The height of the protected conductors has not changed with respect to their initial position.

- The mechanisms holding the conductors in place are in good condition.
- The [covers](#) are in the right place and cover the conductors completely.
- The energized bare conductors are adequately protected by [covers](#).
- The sheath around insulated conductors is in good condition.

For examples of the types of situations to report, see section **Measure 1 – Low voltage: Examples of non-compliance** on page 24.

Note: A cover can be a conductor cover, insulating screen, insulating shield, insulating film or insulating jacket.

If you notice any breakage, displacement or modification of the safety measures that could compromise jobsite safety, stop work immediately and contact Hydro-Québec at **1 800 790-2424**.

Measure 2

Temporary insulation of medium-voltage conductors using covers

SITUATION 1

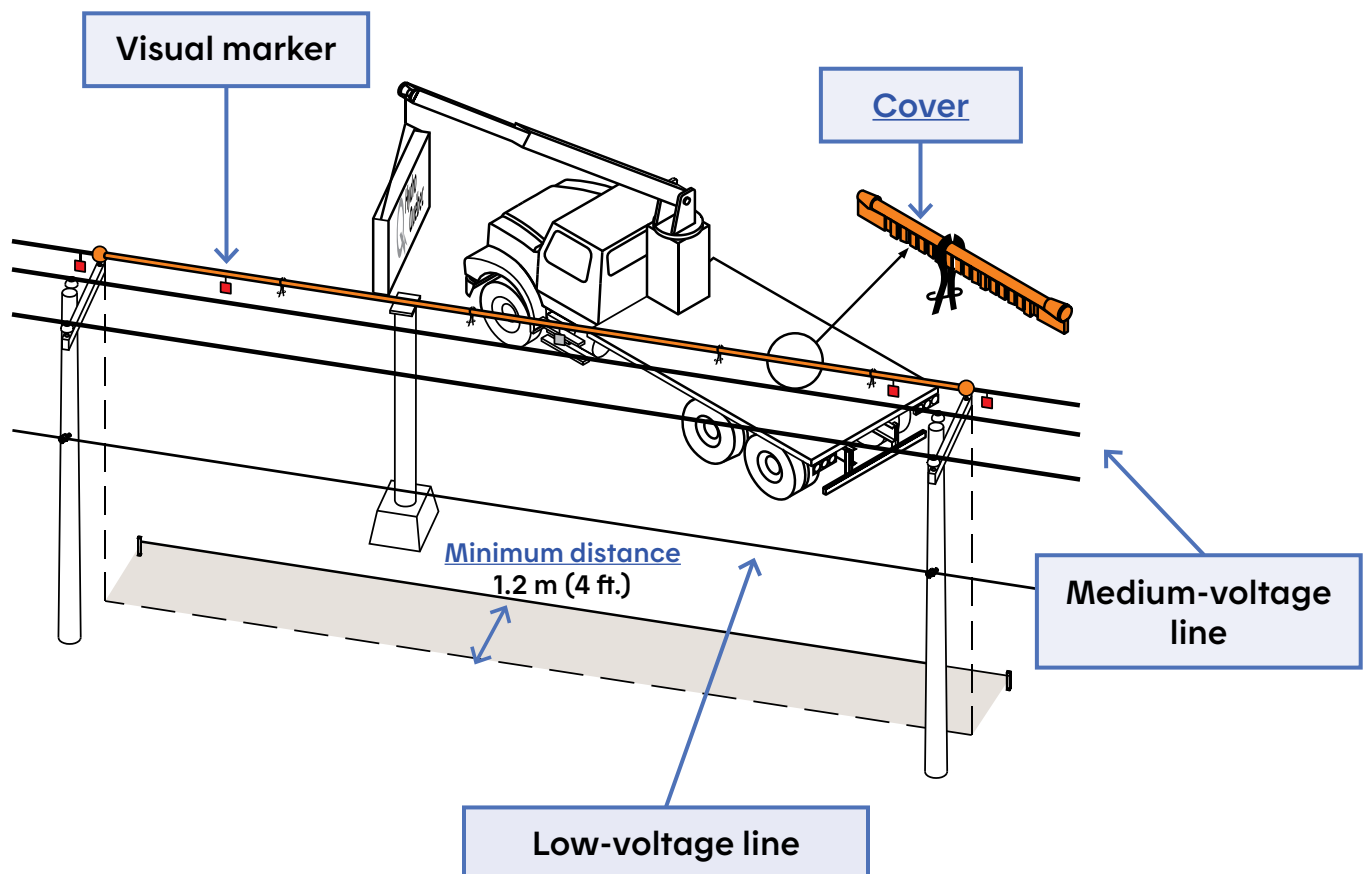

Measure 2

Temporary insulation of medium-voltage conductors using covers

SITUATION 2

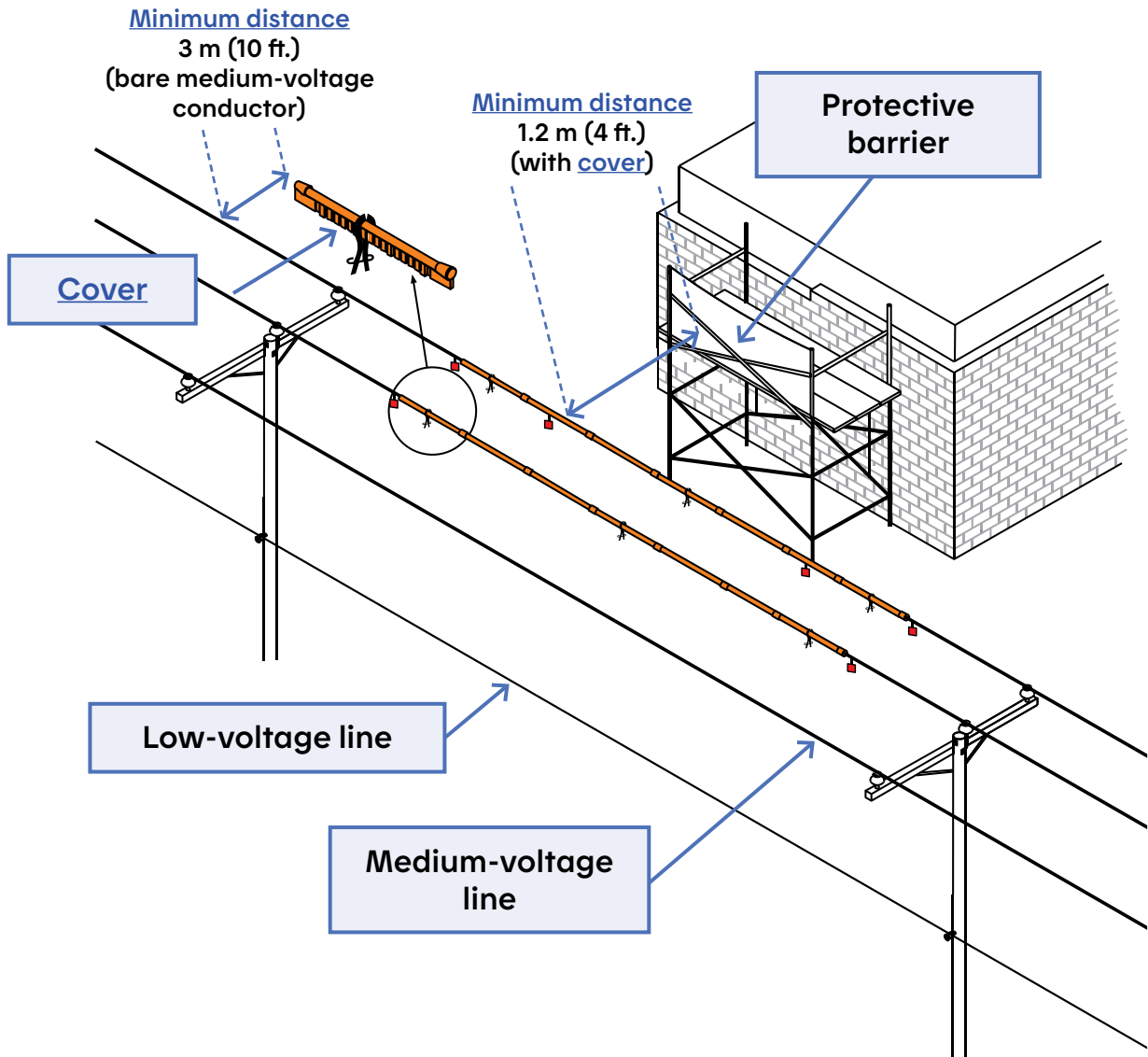

Measure 2

Temporary insulation of medium-voltage conductors using covers

SITUATION 1

Use of a boom truck with or without a range limiter programmed for conducting work near a power line.

SITUATION 2

Use of scaffolding or other similar equipment when conducting work near a power line.

HYDRO-QUÉBEC'S SAFETY MEASURES

The Hydro-Québec team will install [covers](#) on the power line.

Your measures

(WARNINGS)

You must take the measures necessary to ensure that workers* respect the [minimum distance](#) of 1.2 m (4 ft.) from the [covers](#) at all times. For example, you may need to install a protective barrier on the scaffolding.

* The term "worker" here includes any equipment, machinery, load, part, or mobile or fixed scaffolding used by a worker, and all parts of a worker's body (e.g., extended arms) and anything they may be holding in their hands.

CHECKING MEASURES

For the medium-voltage conductors, on a daily basis, you must ensure that:

- The safety measures implemented are compliant with the measures set out in the *Convention – Intervention à proximité de lignes électriques* (agreement to conduct work near power lines).
- The height of the protected conductors has not changed with respect to their initial position.
- The mechanisms holding the conductors in place are in good condition.
- The [covers](#) are in the right place and cover the conductors completely.

For examples of properly installed equipment, see section **Measure 2 – Medium voltage: Examples of compliant safety measures** on page 25.

For examples of the types of situations to report, see section **Measure 2 – Medium voltage: Examples of non-compliance** on page 25.

For the [covers](#), on a daily basis, you must ensure that:

- They are in good condition.
- They are not covered in dirt and/or debris.
- They do not have burn marks.
- Their color has not changed.
- They are not defective or damaged.
- No part of the conductor is exposed at the meetings between two [covers](#). The covers should interlock tightly with one another and no part of the conductor should be visible.

If you notice any breakage, displacement or modification of the safety measures that could compromise jobsite safety, stop work immediately and contact Hydro-Québec at **1 800 790-2424**.

Measure 3

Moving medium-voltage conductors using temporary H-frames

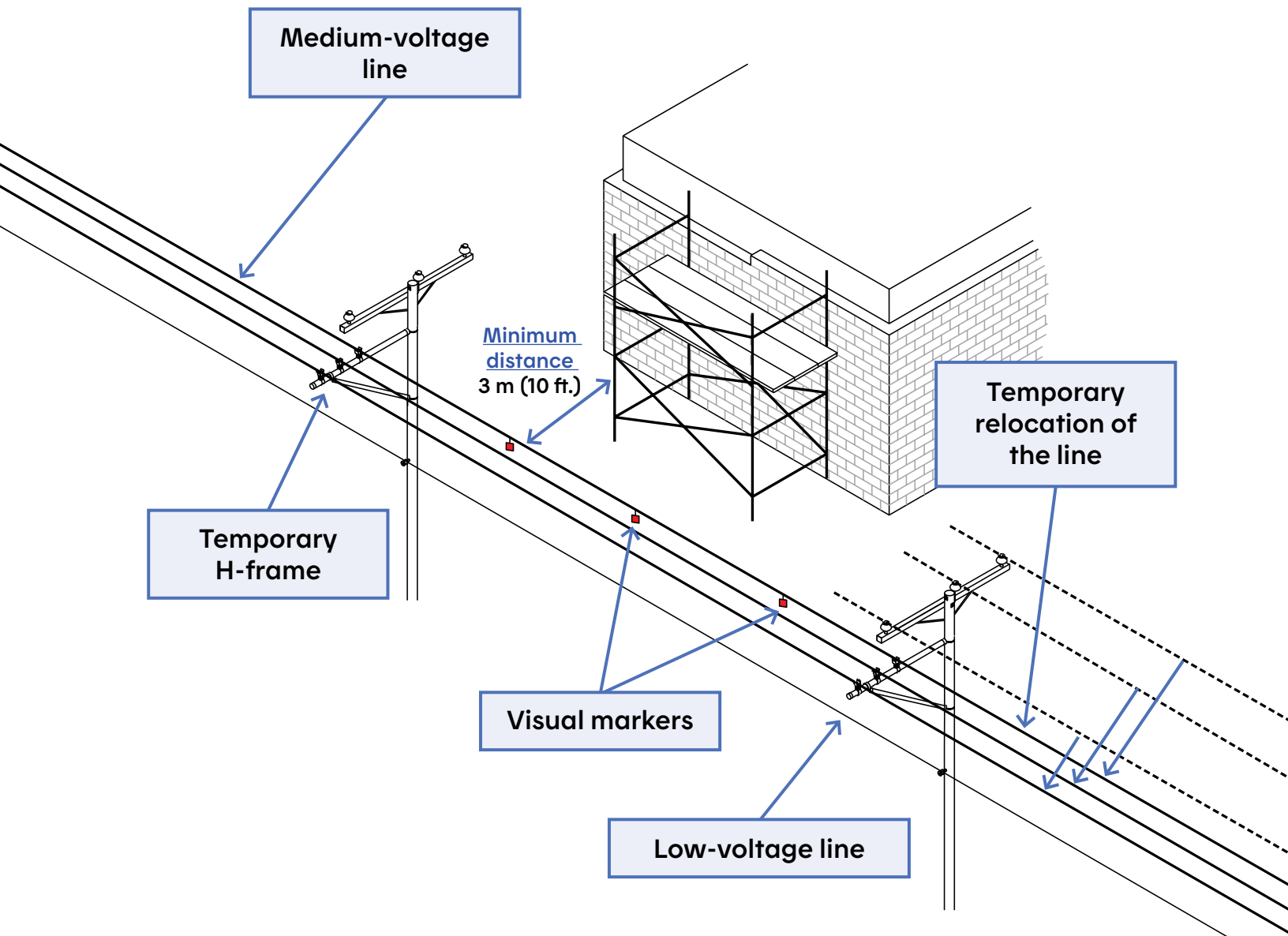

Measure 3

Moving medium-voltage conductors using temporary H-frames

SITUATION

Work to be done near a power line. The poles supporting the power line on the jobsite must not have any equipment (e.g., a transformer).

HYDRO-QUÉBEC'S SAFETY MEASURES

The Hydro-Québec team will install temporary H-frames on the poles and move some or all of the medium-voltage conductors onto those frames so that the [minimum distance](#) of 3 m (10 ft.) can be respected. Hydro-Québec will also install visual markers to remind workers that the line is still energized (live).

Your measures

(WARNINGS)

You must take the measures necessary to ensure that workers* respect the minimum distance of 3 m (10 ft.) from medium-voltage conductors at all times.

* The term “worker” here includes any equipment, machinery, load, part, or mobile or fixed scaffolding used by a worker, and all parts of a worker’s body (e.g., extended arms) and anything they may be holding in their hands.

CHECKING MEASURES

You must ensure that the integrity of the power line in the secured area remains the same as when the safety measures were first implemented.

If you notice any breakage, displacement or modification of the safety measures that could compromise jobsite safety, stop work immediately and contact Hydro-Québec at **1 800 790-2424**.

Measure 4

De-energizing part of the line with or without a bypass

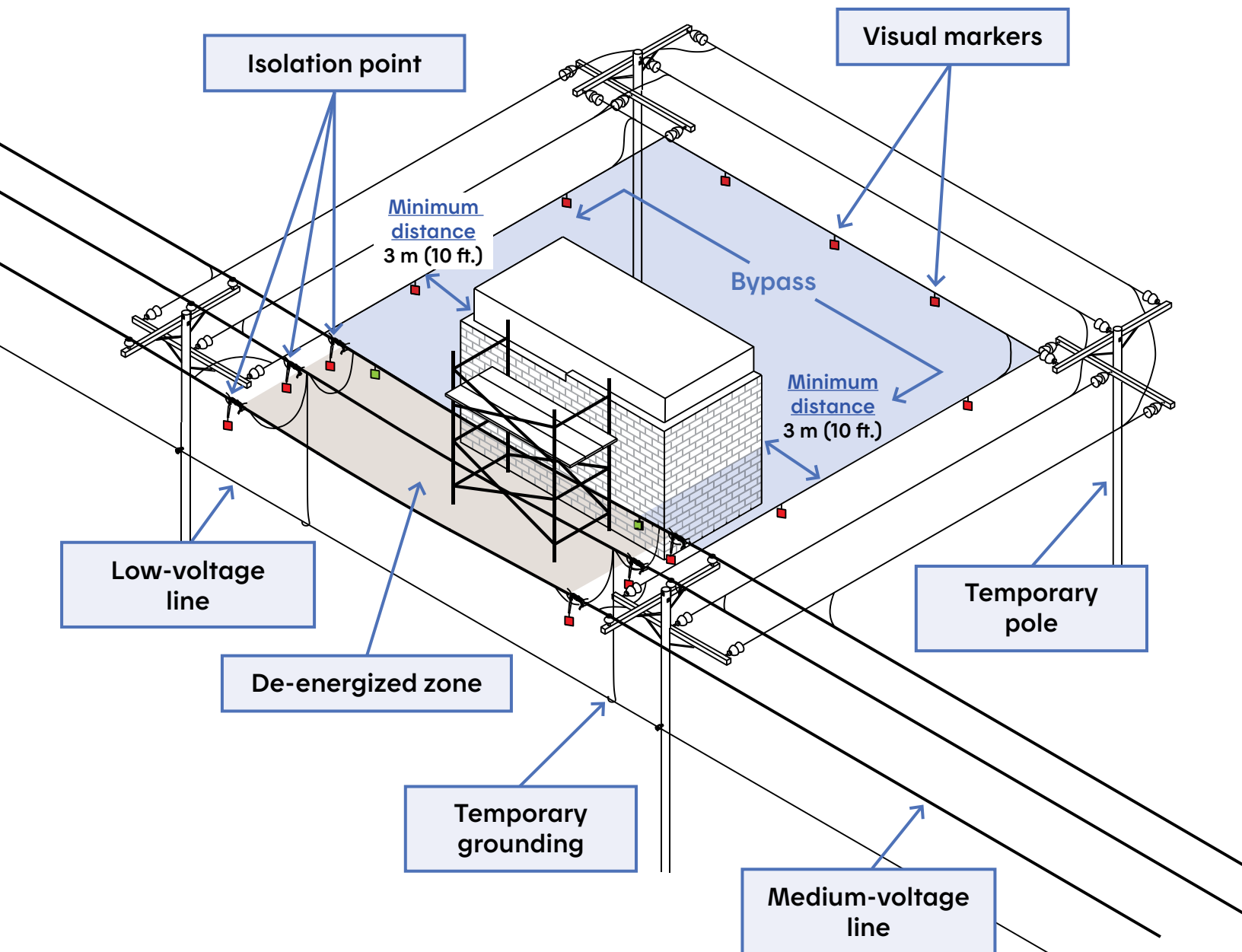

Measure 4

De-energizing part of the line with or without a bypass

SITUATION

Work to be carried out at less than the [minimum distance](#) of 3 m (10 ft.) from a medium-voltage line and none of the other measures, which do not interrupt service continuity, can be used on this part of the line.

HYDRO-QUÉBEC'S SAFETY MEASURES

The Hydro-Québec team will de-energize part of the line (with or without a bypass) to secure

the jobsite. If a bypass is necessary, the work required is more complex and can be lengthier and more costly. If temporary poles must be installed, they will be removed by Hydro-Québec when the work is finished.

Hydro-Québec will also install visual markers to indicate which conductors are energized and which are de-energized.

Your measures (WARNINGS)

You must ensure that there is zero contact between the low-voltage conductors and the scaffolding or any other equipment used for the work. Contact with the energized non-insulated parts of the service loop could lead to electric shock.

You must also ensure that there is zero contact between the medium-voltage conductors in the de-energized part of the line and the scaffolding or any other equipment used for the work.

If a bypass has been set up, you must take the measures required to ensure that workers* respect the [minimum distance](#) of 3 m (10 ft.) from the medium-voltage conductors that are part of the bypass at all times. These conductors are energized.

* The term “worker” here includes any equipment, machinery, load, part, or mobile or fixed scaffolding used by a worker, and all parts of a worker’s body (e.g., extended arms) and anything they may be holding in their hands.

IMPORTANT

If the line has been de-energized without a bypass, the duration of the work will be limited by the power system’s operating constraints.

CHECKING MEASURES

You must verify the compliance of the temporary grounding systems (see photo in section **Measure 4 – Medium voltage: Examples of compliant safety measures** on page 26).

If you notice any breakage, displacement or modification of the safety measures that could compromise jobsite safety, stop work immediately and contact Hydro-Québec at **1 800 790-2424**.

Measure 5

Temporary support of a pole

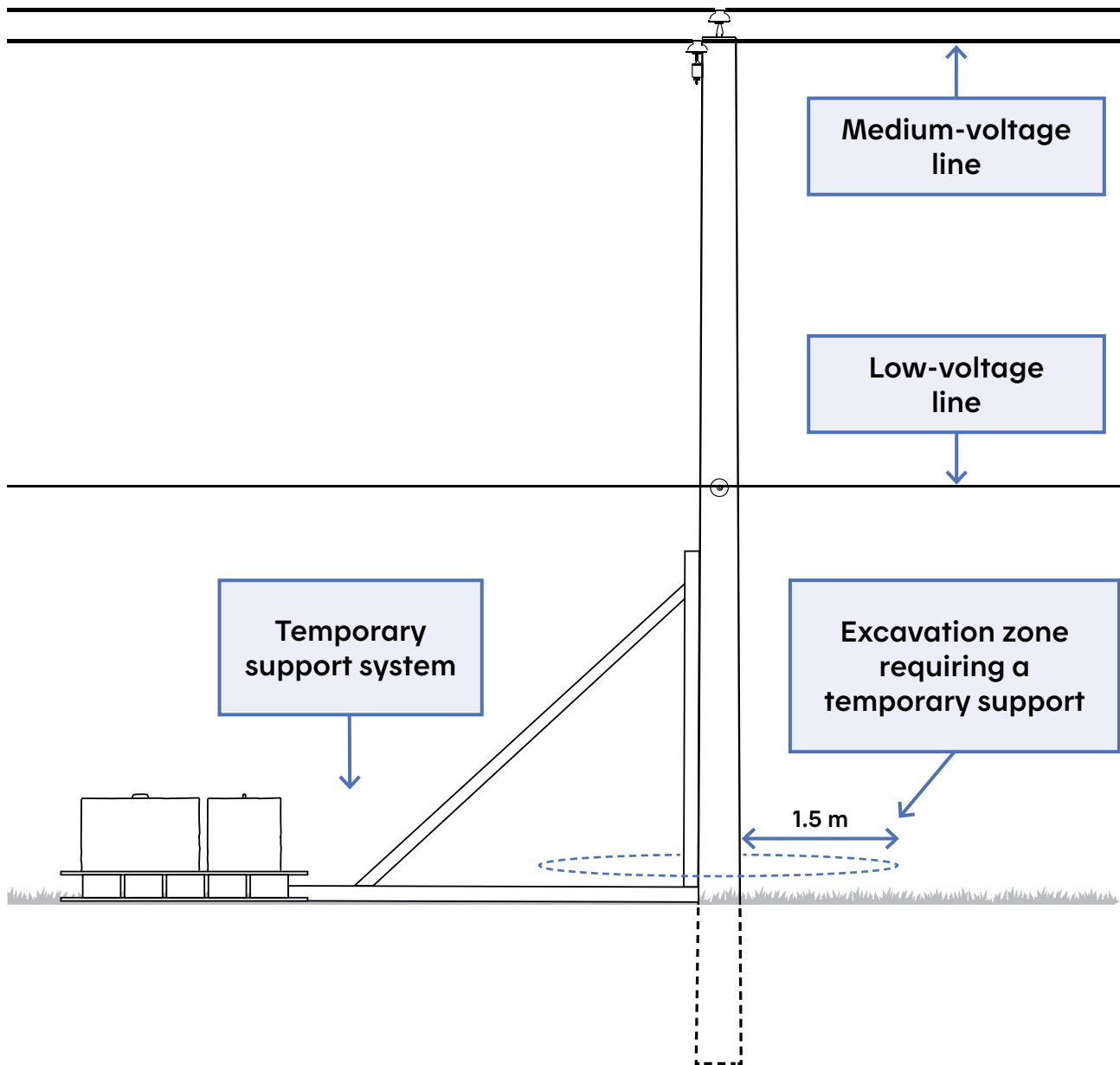

Measure 5

Temporary support of a pole

SITUATION

Temporary support of a power line pole to allow for excavation work to be done at a distance of less than 1.5 m (5 ft.) from the pole, whether the pole contains Hydro-Québec equipment (transformer, guy anchoring, etc.) or not.

HYDRO-QUÉBEC'S SAFETY MEASURES

In this situation, Hydro-Québec will verify compliance with the requirements in order to approve the safety measures or have them corrected.

Your measures (WARNINGS)

BEFORE STARTING WORK

You must provide the Hydro-Québec representative with a plan that is signed and sealed by an engineer for each of the temporary support systems that you intend to use, specifying their location.

The documents submitted must also include the installation procedures for these systems, and these procedures must also be signed and sealed by an engineer. Once compliance with the requirements (sealed plans and calculation documents, plans illustrating the situation and the actual location of the post for which the support system is required) has been verified by the Hydro-Québec representative, a confirmation will be sent to indicate the support systems can be installed.

DURING THE WORK

You must take the measures necessary to ensure that the [minimum distance](#) of 3 m (10 ft.) from medium-voltage conductors and bare low-voltage conductors is respected

at all times by workers*. If this distance cannot be respected, contact the technician assigned to your file to request additional safety measures.

* The term "worker" here includes any equipment, machinery, load, part, or mobile or fixed scaffolding used by a worker, and all parts of a worker's body (e.g., extended arms) and anything they may be holding in their hands.

IMPORTANT

Please note that the support systems should not have any components (e.g., mounting or assembly mechanisms) that need to be bolted or nailed into the pole.

If these requirements are not respected, you will be ordered by Hydro-Québec to immediately stop work and implement corrective measures.

Note: For information on supporting underground power lines during excavation, refer to [page 28](#).

Measure 6

Securing a site so that a load can be transported under a power line

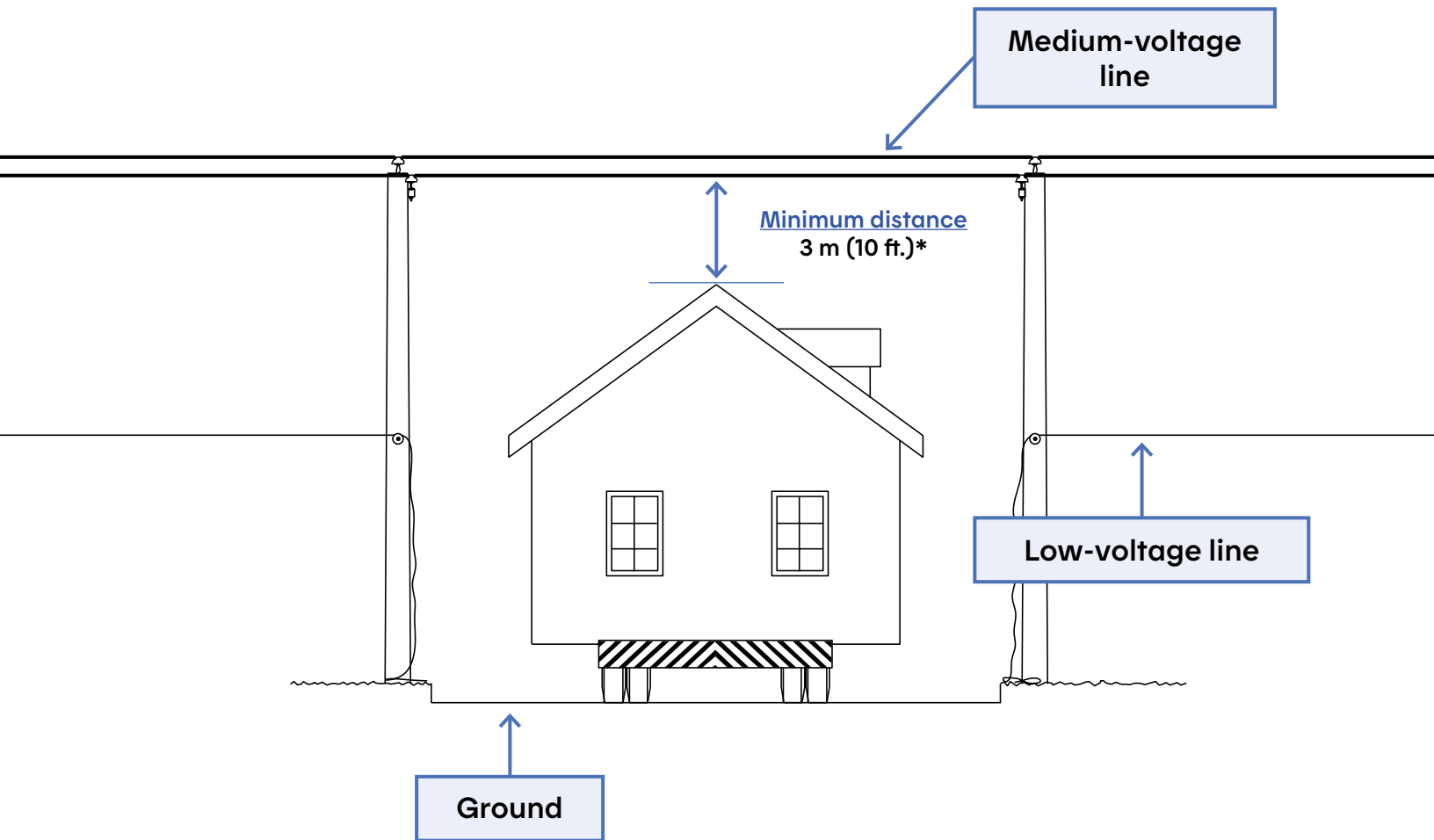

* 1.2 m (4 ft.) if a Hydro-Québec representative accompanies the convoy for the entire length of its trip.

Measure 6

Securing a site so that a load can be transported under a power line

SITUATION

Relocation of an oversize load that has to pass under one or more power lines.

HYDRO-QUÉBEC'S SAFETY MEASURES

At your expense, and in line with the *Conditions of Service* in effect, Hydro-Québec will take all the measures necessary to ensure that the [minimum distance](#) is maintained between the highest part of your load and the conductors.

If a Hydro-Québec representative accompanies the convoy, the minimum distance that must be maintained for the entire length of the trip is 1.2 m (4 ft.). However, if a Hydro-Québec representative is not present during the convoy's relocation, the minimum distance that must be maintained is 3 m (10 ft.).

Your measures (WARNINGS)

When the load is traveling under the power lines, there should be no one on the load or on the transport platform.

You must take the measures necessary to ensure that the [minimum distance](#) of 3 m (10 ft.) from conductors is respected at all times by all workers*.

* The term "worker" here includes any equipment, machinery, load, part, or mobile or fixed scaffolding used by a worker, and all parts of a worker's body (e.g., extended arms) and anything they may be holding in their hands.

If you notice any breakage, displacement or modification of the safety measures that could compromise jobsite safety, stop work immediately and contact Hydro-Québec at **1 800 790-2424**.

Measure 7

Standard E.32.1-01 related to municipal public lighting

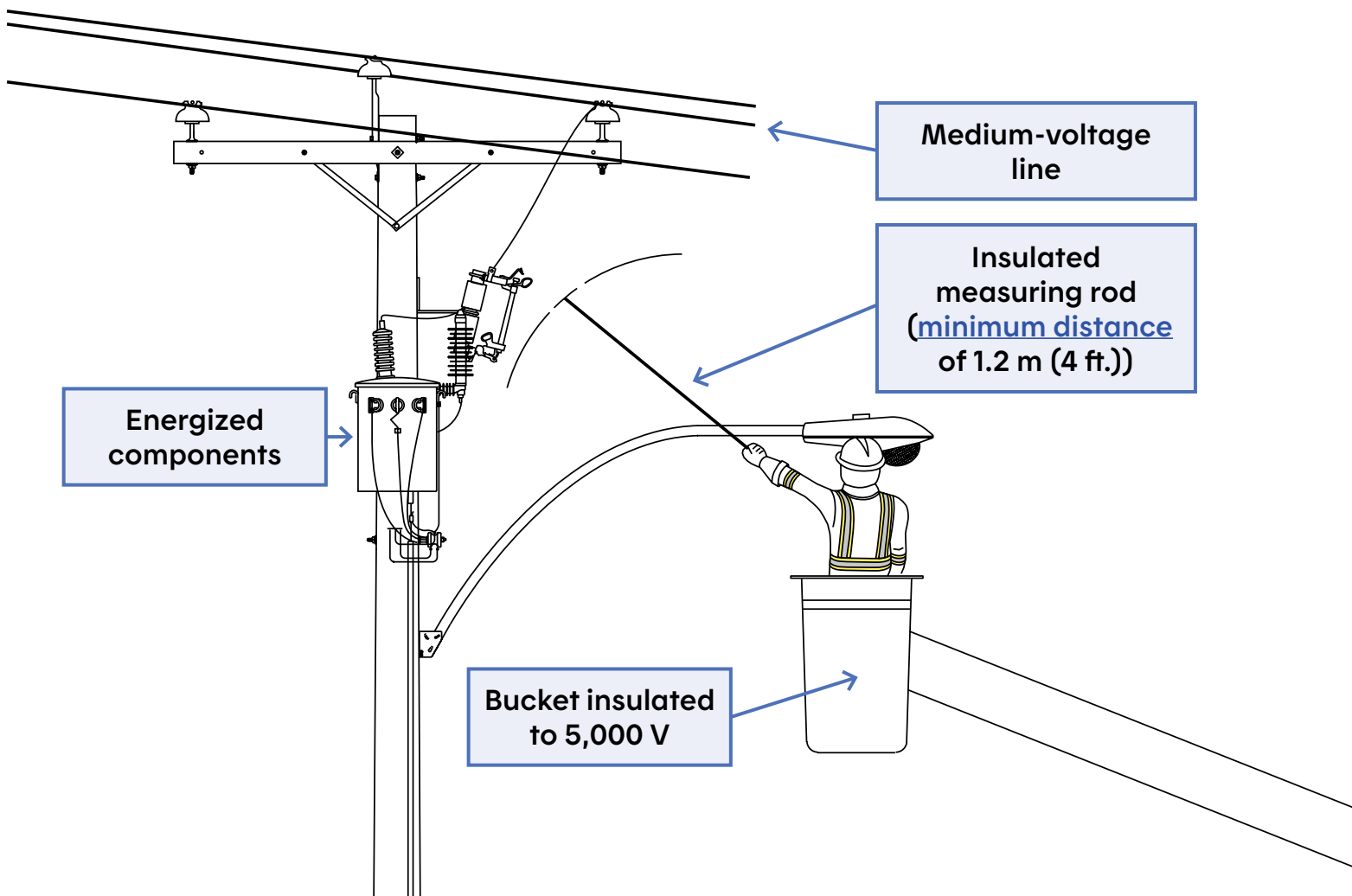

Measure 7

Standard E.32.1-01 related to municipal public lighting

SITUATION

Maintenance work required on municipal public lighting equipment that is located on Hydro-Québec's equipment or less than 3 m (10 ft.) from energized medium-voltage components.

HYDRO-QUÉBEC'S SAFETY MEASURES

Hydro-Québec periodically reviews its Standard E.32.1-01 (in French only) (<https://www.hydroquebec.com/data/cmeq/pdf/e32101.pdf>), which covers the minimum requirements for all work related to municipal public lighting. The company also trains electrical contractors on this standard.

Your measures

(WARNINGS)

Before starting the work, you must ensure that it will be done by a qualified and duly trained* electrical contractor, who will work from a 5,000-V insulated bucket (bucket truck) and use an insulated measuring stick to gauge the distance from Hydro-Québec's equipment so as to keep at least 1.2 m (4 ft.) away from these installations.

During the work, you must ensure that the safety measures prescribed in Standard E.32.1-01 are respected by everyone on the jobsite.

* The electrical contractor must have completed the Hydro-Québec training on Standard E.32.1-01. To register for the training, the contractor must fill out the form Formulaire d'inscription à la formation Travaux d'éclairage public (in French only) (<https://www.hydroquebec.com/sefco2016/fr/cmeq-inscription-formation-eclairage.html>).

If you notice any breakage, displacement or modification of the safety measures that could compromise jobsite safety, stop work immediately and contact Hydro-Québec at **1 800 790-2424**.

Checking Hydro-Québec's safety measures on your jobsite

The following pages contain:

- A list of general checks that the [main requestor](#) must complete on a daily basis (depending on the measures used on the jobsite) to ensure the safety of workers and the integrity of Hydro-Québec's power system.
- Photos of compliant and non-compliant protective features for some of the most common measures.

General checks

As the [main requestor](#), you must check on a daily basis all of the following that apply, depending on the measures used on the jobsite:

Medium- and low-voltage conductors

- The safety measures implemented are compliant with the measures set out in the *Convention – Interventions à proximité de lignes électriques* (agreement to conduct work near power lines) signed with Hydro-Québec before the start of the work.
- The height of the protected conductors has not changed with respect to their initial position.
- The mechanisms holding the conductors in place are in good condition.
- The [covers](#) installed by Hydro-Québec are in the right place and cover the conductors completely.

Low-voltage conductors only

- The [covers](#) installed by Hydro-Québec adequately protect bare energized conductors.
- The sheath around insulated conductors is in good condition.

Conductor covers installed by Hydro-Québec

- They are in good condition.
- They are not covered in dirt or debris.
- They do not have burn marks.
- Their color has not changed.
- They are not defective or damaged.
- No part of the conductor is exposed at the meetings between two [covers](#). The covers should interlock tightly with one another and no part of the conductor should be visible.

Rain

Rain at a jobsite can compromise safety measures. When it is raining, make sure to respect the regular [minimum distance](#) of 3 m (10 ft.) from all components of the medium-voltage system, whether they are covered or not.

Wind and freezing rain

An accumulation of wind and freezing rain can impact conductors and their [covers](#) and cause damage to Hydro-Québec's equipment. As the [main requestor](#), you must notify Hydro-Québec if you notice any snow or ice on conductor [covers](#), or if you see covers hit against one another from the wind. During periods of wind and freezing rain, checks should be performed more frequently (as often as necessary).

Reporting anomalies

If an anomaly is detected, or you have any reason to believe that the conductor [covers](#) are not safe, stop work immediately and contact Hydro-Québec at **1 800 790-2424**.

If you believe that the situation at the jobsite represents a public safety risk or if someone's life is in danger, call **911**. The appropriate authorities and Hydro-Québec will be notified at the same time and assistance will be dispatched.

Measure 1 – Low voltage

EXAMPLES OF NON-COMPLIANCE

Below are examples of situations that can compromise the safety of the jobsite. If you notice any situations similar to these, stop work immediately and contact Hydro-Québec at **1 800 790-2424**.

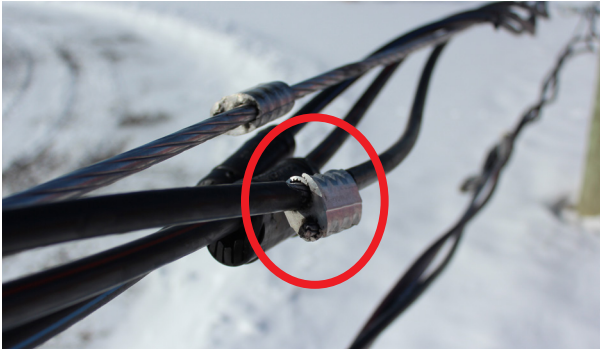

[Cover](#) missing on the connection



Damaged conductor sheath

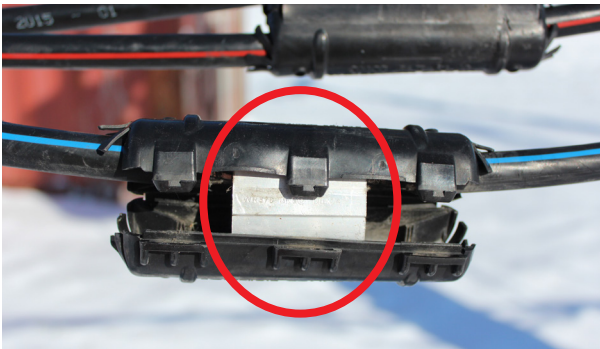

Open or damaged [cover](#)

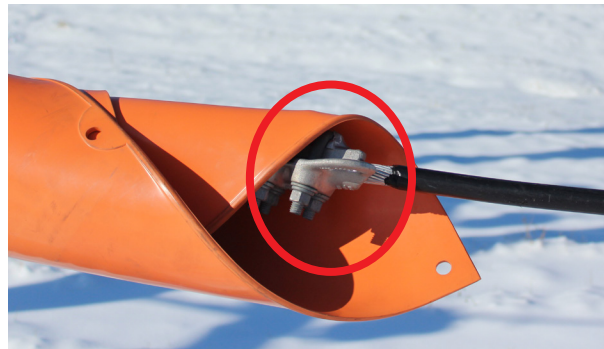

Part of the conductor is exposed

Measure 2 – Medium voltage

EXAMPLES OF COMPLIANT SAFETY MEASURES

Below are examples of conductor [covers](#) correctly installed by Hydro-Québec and one example of a conductor that is properly attached to the top of a pole.



Correctly installed conductor [covers](#)



Tie wires in good condition

EXAMPLES OF NON-COMPLIANCE

Below are examples of situations that can compromise the safety of the jobsite. If you notice any situations similar to these, stop work immediately and contact Hydro-Québec at **1 800 790-2424**.



Part of conductor exposed due to faulty interlocking of conductor [covers](#)



Incorrectly superposed conductor [covers](#)



Bare conductor due to an incorrectly attached conductor [cover](#)



Loosened tie wires

Measure 4 – Medium voltage

GROUNDING EXAMPLE

This section shows you what a grounding system that has been correctly installed by Hydro-Québec should look like. This type of grounding system is used to de-energize part of the power line with or without a bypass. If you are unsure whether the grounding system at your jobsite is compliant, or if the grounding equipment is no longer in place, stop work immediately and contact Hydro-Québec at **1 800 790-2424**.



Grounding to de-energize part of a medium-voltage line

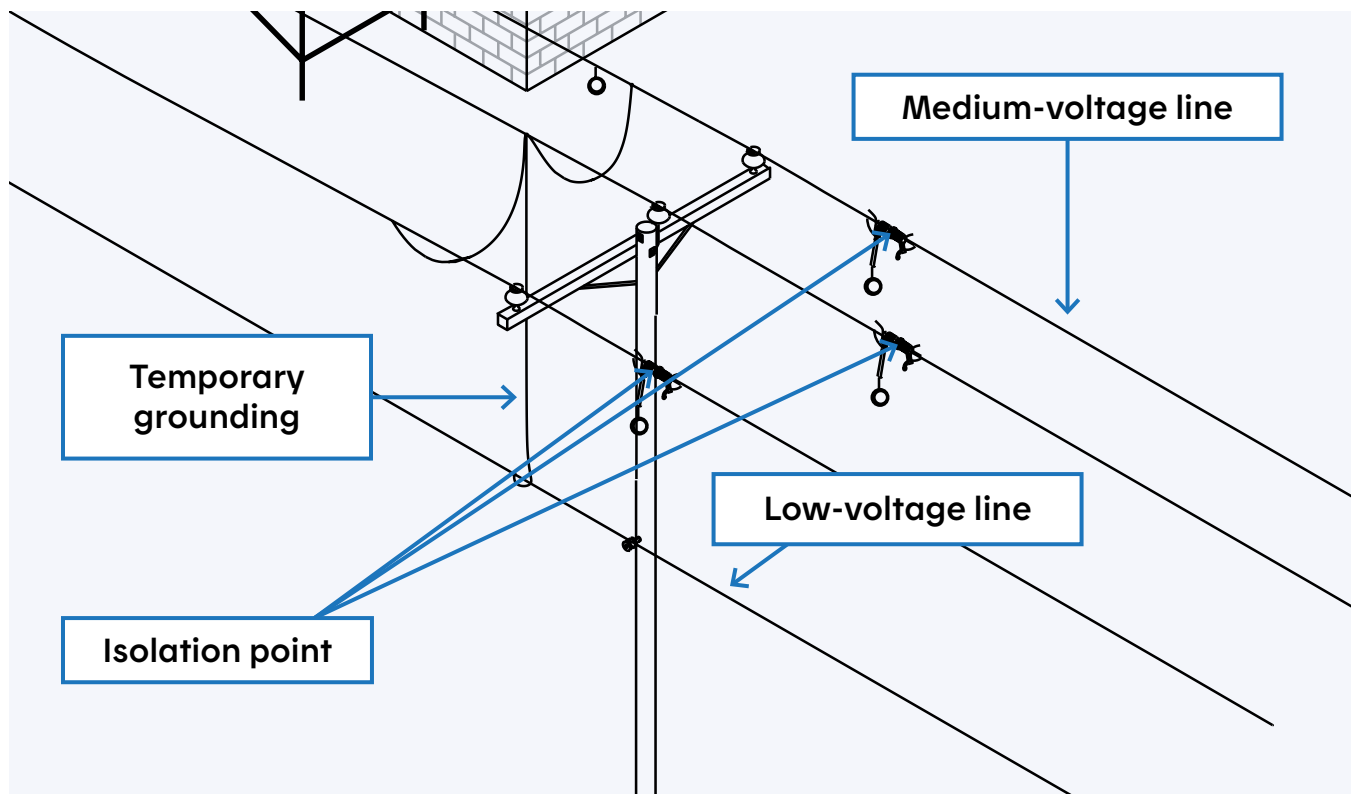

Compliant grounding system: every medium-voltage conductor is connected to a grounding point.

Work near underground power lines

The following pages provide general instructions on the steps and measures you need to take when working near equipment that is part of Hydro-Québec's underground system. For any specific questions about your jobsite and the measures used there, contact the technician in charge of your file.

Introduction

If you are planning excavation work at a site that may contain underground infrastructure (power lines, water or gas pipes, etc.), there are certain precautions you need to take.

As the [main requestor](#) for a project, these precautions are your responsibility, whether you are a contractor, project manager or private individual. The procedure to follow is described in the following pages.

Preliminary site visit

You must visit the jobsite at least 30 business days before the start of the work to determine whether an underground power system is present.

If there are buildings, facilities or equipment near the jobsite that are powered by electricity but you do not see any power lines, this means the power system is underground. An underground system can also be confirmed by the presence of specific infrastructure (pad mounted transformers or other similar equipment, handhole plates, etc.).

If you suspect the presence of an underground power system, you must follow the steps described in the section **Info-Excavation requests** on page 29. The section **Hydro-Québec requests** on page 30 may also apply.

In addition, the site may contain other, non-electrical underground infrastructure (water and gas pipes, etc.). When in doubt, make sure to follow the process described in the **Info-Excavation requests** section on page 29.



Info-Excavation requests

As the [main requestor](#), you must take the following steps to find out about the underground infrastructure present on the jobsite.

- 1 To properly plan the work, you must [submit an engineering request](https://www.info-ex.com/en/request/engineering-request/) to Info-Excavation to receive the plans of the underground infrastructure present on your jobsite. This service is free and plans are generally sent within three business days.
- 2 Once you have sent your request, Info-Excavation checks its database to confirm whether its member companies have any underground infrastructure in the area covered by your jobsite and sends you the plan for that area.
- 3 If the plan you receive from Info-Excavation shows that underground infrastructure is present on the jobsite, you must [submit a marking request](https://www.info-ex.com/en/) to Info-Excavation. This service is free.
- 4 Each member company with underground infrastructure on your jobsite will then visit the site and mark the location of their infrastructure on the ground in their assigned color. When they have completed the marking, they will send you a confirmation. You must wait to receive confirmations from all member companies with infrastructure on your jobsite before starting work.
- 5 If the jobsite is located in a municipality that is not a member of Info-Excavation, or if the owner of some of the underground infrastructure present on the jobsite is not a member of Info-Excavation, you will need to contact the municipality or the owner directly to find out the location of the infrastructure.

More information

For more information on conducting work near underground infrastructure, consult the [Guidelines for Excavation Work Done Near Our Underground Infrastructures](https://www.info-ex.com/en/14649-2/) (https://www.info-ex.com/en/14649-2/), available on the Info-Excavation website.



Hydro-Québec requests

Complying with clearance zones

- 1 If you are planning to dig near electrical equipment located either above-ground (including the equipment base) or below-ground (underground cable vault, transformer vault, etc.), you must respect the clearance required around the equipment or structure.

Call Hydro-Québec at 1 888 385-7252 (residential customers) or 1 877 956-5696 (business customers) to submit a request about the clearance required.
- 2 Within a few days, a Hydro-Québec representative will contact you to assess your request.
- 3 Once the assessment has been completed, you will have to provide the Hydro-Québec representative with a list of the steps involved in the work, and the work methods, materials and equipment you plan to use.
- 4 The Hydro-Québec representative will then send you the perimeter of the clearance zone you need to respect.

Supporting duct banks

If you are planning excavation work near or underneath Hydro-Québec's electrical duct banks (whether these are encased in concrete or not), you must make sure to temporarily support the duct banks to prevent them from breaking, sagging or tipping over.

- 1 Call Hydro-Québec at 1 888 385-7252 (residential customers) or 1 877 956-5696 (business customers) to submit a request about supporting electrical duct banks.



- 2 Within a few days, a Hydro-Québec representative will contact you to assess your request.
- 3 Before the start of the work, you may be required to submit a shoring or temporary support plan created specifically for the work you are planning and signed and sealed by an engineer.

Altering duct banks

For any work that involves changes to electrical duct banks (breaking concrete, relocation, support, etc.), a request must be submitted to Hydro-Québec beforehand.

- 1 Call Hydro-Québec at 1 888 385-7252 (residential customers) or 1 877 956-5696 (business customers) to submit a request about making changes to electrical duct banks.
- 2 Within a few days, a Hydro-Québec representative will contact you to assess your request.
- 3 Before the start of the work, a plan and procedures created specifically for the work you are planning, and signed and sealed by an engineer, must be submitted to the Hydro-Québec technician in charge of your file.

Work to alter electrical duct banks can only be carried out by accredited contractors, who are registered on the [list of companies qualified to conduct work on Hydro-Québec's underground conduit system \(in French only\)](https://www.hydroquebec.com/data/fournisseurs/pdf/liste-entreprises-qualifiees-canalisation-souterraine.pdf) (<https://www.hydroquebec.com/data/fournisseurs/pdf/liste-entreprises-qualifiees-canalisation-souterraine.pdf>). To be added to the list, companies must [complete the accreditation process \(in French only\)](https://www.hydroquebec.com/data/fournisseurs/pdf/qualification-canalisations-souterraines-distribution-instructions.pdf) (<https://www.hydroquebec.com/data/fournisseurs/pdf/qualification-canalisations-souterraines-distribution-instructions.pdf>).

Starting the work

REMINDER: Before doing any excavation work, you must submit an engineering request to Info-Excavation (see section **Info-Excavation requests** on page 29), or to any municipality or other stakeholder who owns infrastructure on the jobsite and is not a member of Info-Excavation, and ask them to mark the underground infrastructure present on the jobsite. You must also ensure that you have received all the marking confirmations sent by the companies.

REMINDER: If applicable, you must also have completed the steps outlined in the **Hydro-Québec requests** section on page 30.

REMINDER: Work that involves changes to electrical duct banks can only be done by an accredited contractor. See the **Hydro-Québec requests** section on page 30.

Mechanical excavation is not permitted within a buffer zone of 1 m (3 ft.) from each side of any underground infrastructure until the exact location of the infrastructure has been visually verified through non-destructive excavation. Non-destructive excavation techniques include manual excavation, air excavation and hydro excavation.

If you notice any breakage, displacement or modification of the safety measures that could compromise jobsite safety, stop work immediately and contact Hydro-Québec at **1 800 790-2424**.

Important links

- General Information Sheet – Work Near Power Lines (2021)
- Webpage to submit a jobsite safety request
- Webpage to track a request for work
- Conditions of Service

**To contact Hydro-Québec,
dial 1 888 385-7252 (residential customers)
or 1 877 956-5696 (business customers)**

Legal Deposit – Bibliothèque et
Archives nationales du Québec, 2023
ISBN 978-2-550-94326-6 (PDF)

Original text written in French.

Ce document est également publié en français.