

Single-Phase AC Power Circuits

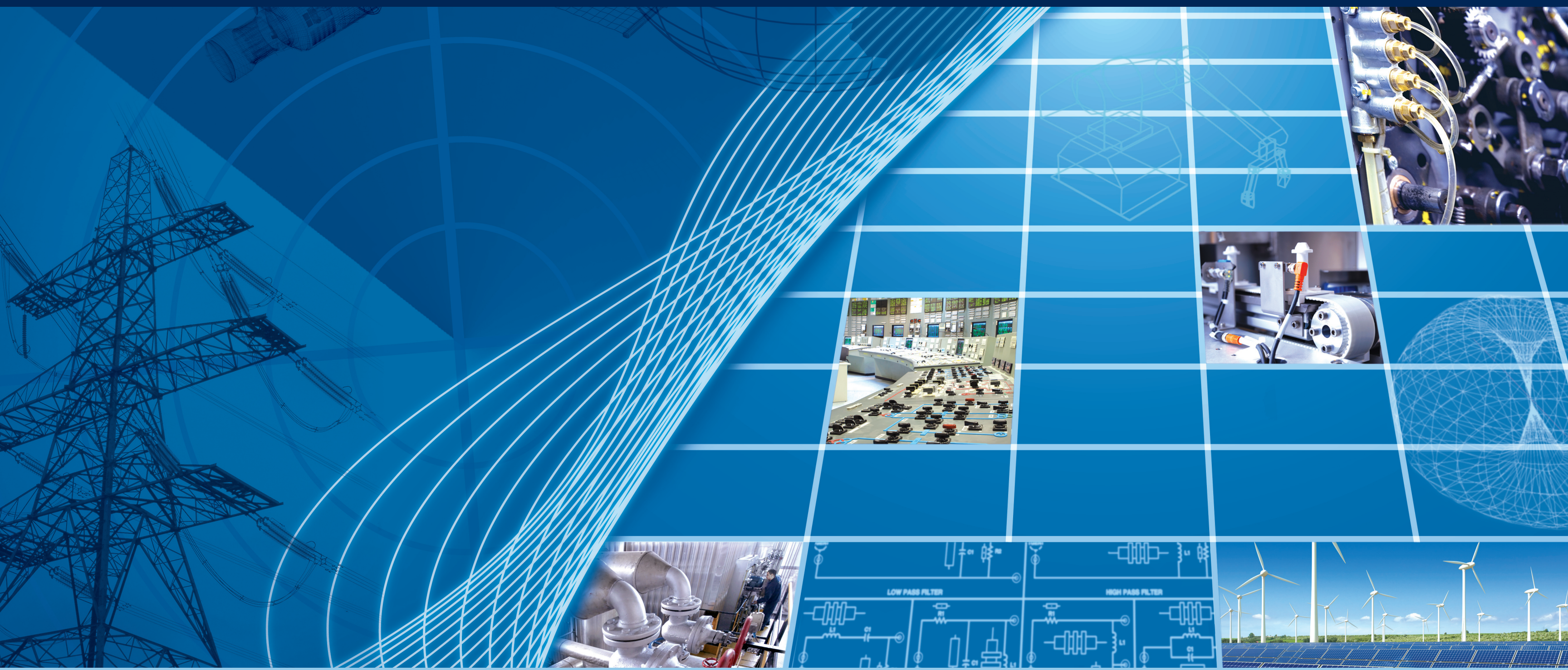

86358-00



3 0 8 6 3 5 8 0 0 0 0 0

Student Manual

Electric Power / Controls

Single-Phase AC Power Circuits

Student Manual
86358-00



First Edition
Published July 2013

© 2010 by Lab-Volt Ltd.
Printed in Canada
All rights reserved

ISBN 978-2-89640-399-8 (Printed version)
ISBN 978-2-89640-710-1 (CD-ROM)

Legal Deposit – Bibliothèque et Archives nationales du Québec, 2010
Legal Deposit – Library and Archives Canada, 2010

No part of this publication may be reproduced, stored in a retrieval system, or transmitted in any form by any means, electronic, mechanical, photocopied, recorded, or otherwise, without prior written permission from Lab-Volt Ltd.

Information in this document is subject to change without notice and does not represent a commitment on the part of Lab-Volt. The Lab-Volt® materials described in this document are furnished under a license agreement or a nondisclosure agreement.

















The Lab-Volt® logo is a registered trademark of Lab-Volt Systems.

Lab-Volt recognizes product names as trademarks or registered trademarks of their respective holders.

All other trademarks are the property of their respective owners. Other trademarks and trade names may be used in this document to refer to either the entity claiming the marks and names or their products. Lab-Volt disclaims any proprietary interest in trademarks and trade names other than its own.

Safety and Common Symbols

The following safety and common symbols may be used in this manual and on the Lab-Volt equipment:

Symbol	Description
	DANGER indicates a hazard with a high level of risk which, if not avoided, will result in death or serious injury.
	WARNING indicates a hazard with a medium level of risk which, if not avoided, could result in death or serious injury.
	CAUTION indicates a hazard with a low level of risk which, if not avoided, could result in minor or moderate injury.
	CAUTION used without the <i>Caution, risk of danger</i> sign  , indicates a hazard with a potentially hazardous situation which, if not avoided, may result in property damage.
	Caution, risk of electric shock
	Caution, hot surface
	Caution, risk of danger
	Caution, lifting hazard
	Caution, hand entanglement hazard
	Direct current
	Alternating current
	Both direct and alternating current
	Three-phase alternating current
	Earth (ground) terminal
	Protective conductor terminal

Safety and Common Symbols







Symbol	Description
	Frame or chassis terminal
	Equipotentiality
	On (supply)
	Off (supply)
	Equipment protected throughout by double insulation or reinforced insulation
	In position of a bi-stable push control
	Out position of a bi-stable push control

Table of Contents

Preface	xiii
About This Manual	xv
Unit 1 Alternating Current	1
DISCUSSION OF FUNDAMENTALS	1
DC circuits versus ac circuits	1
Alternating current (ac) and ac voltage	2
Alternating current and ac voltage supplied by public power distribution utilities	2
Safety rules.....	3
Ex. 1-1 The Sine Wave.....	5
DISCUSSION.....	5
Relationship between a rotating phasor and a sine wave.....	5
Period and frequency of a sinusoidal voltage or current.....	8
Amplitude and instantaneous value of a sinusoidal voltage or current	8
Effective or root-mean-square (rms) value and heating capacity	10
Effective (rms) value of a sinusoidal voltage or current	10
PROCEDURE	11
Setup and connections.....	11
Measuring voltage, current, and frequency in an ac circuit.....	14
Relationship between frequency and period	16
Measuring voltage, current, and frequency in a series ac circuit	17
Ex. 1-2 Phase Angle and Phase Shift	21
DISCUSSION.....	21
Phase angle.....	21
Phase shift.....	23
PROCEDURE	25
Setup and connections.....	25
Measuring the phase shift between two voltage sine waves in a resistor-inductor (RL) circuit	27
Measuring the phase shift between two voltage sine waves in a resistor-capacitor (RC) circuit.....	29
Ex. 1-3 Instantaneous Power and Average Power	35
DISCUSSION.....	35
Instantaneous power	35
Average power	36
Rationale behind rms values	37

Table of Contents

	PROCEDURE	38
	Setup and connections	38
	Average power measurements	40
	Rationale behind rms values	42
Unit 2	Resistance, Reactance, and Impedance.....	47
	DISCUSSION OF FUNDAMENTALS	47
	Introduction to inductors and capacitors.....	47
	Distinction between resistance, reactance, and impedance ...	48
Ex. 2-1	Inductive Reactance	51
	DISCUSSION.....	51
	Inductors and inductive reactance.....	51
	Inductive phase shift.....	52
	PROCEDURE	52
	Setup and connections	52
	Inductance and inductive reactance.....	54
	Effect of frequency on the inductive reactance	56
	Measuring the inductive phase shift.....	57
Ex. 2-2	Capacitive reactance	61
	DISCUSSION.....	61
	Capacitors and capacitive reactance	61
	Capacitive phase shift	62
	PROCEDURE	62
	Setup and connections	62
	Capacitance and capacitive reactance.....	64
	Effect of the frequency on the capacitive reactance	66
	Measuring the capacitive phase shift	67
Ex. 2-3	Impedance	71
	DISCUSSION.....	71
	Phasor diagrams related to resistors, inductors, and capacitors	71
	Phasor diagram related to a resistor	71
	Phasor diagram related to an inductor	72
	Phasor diagram related to a capacitor.....	73
	Equivalent reactance of series-connected reactive components	73
	Impedance of resistors, inductors, and capacitors connected in series.....	75
	Impedance of resistors, inductors, and capacitors connected in parallel.....	77

Table of Contents

	PROCEDURE	78
	Setup and connections	79
	Equivalent reactance of a series LC circuit	81
	Impedance of a series RL circuit	83
	Impedance of a series RC circuit	85
	Impedance of a series RLC circuit	86
	Impedance of a parallel RL circuit	87
	Impedance of a parallel RC circuit	89
Unit 3	Power in AC Circuits	95
	DISCUSSION OF FUNDAMENTALS	95
	Introduction to active, reactive, and apparent power	95
Ex. 3-1	Active and Reactive Power	97
	DISCUSSION	97
	Active power in a resistor	97
	Reactive power in an inductor	98
	Reactive power in a capacitor	99
	Power Meter	100
	PROCEDURE	101
	Setup and connections	101
	Active power in a resistor	103
	Reactive power in an inductor	105
	Reactive power in a capacitor	107
Ex. 3-2	Apparent Power and the Power Triangle.....	111
	DISCUSSION	111
	Phasor diagrams related to active and reactive power	111
	Phasor diagram related to the active power in a resistor	111
	Phasor diagram related to the reactive power in an inductor ...	112
	Phasor diagram related to the reactive power in a capacitor ...	113
	Apparent power	114
	Power triangle.....	115
	Power factor	115
	PROCEDURE	116
	Setup and connections	116
	Total reactive power in a circuit.....	118
	Apparent power, power factor, and power triangle	120
Unit 4	AC Circuits Analysis.....	127
	DISCUSSION OF FUNDAMENTALS	127
	Introduction to circuit analysis	127
	Circuit analysis methods	127

Table of Contents

Ex. 4-1	Solving Simple AC Circuits Using Circuit Impedance	
	Calculation.....	129
	DISCUSSION.....	129
	Solving simple parallel circuits	129
	Example	130
	Solving simple series circuits	131
	Example	132
	PROCEDURE	133
	Setup and connections	133
	Solving a simple parallel ac circuit	135
	Solving a simple series ac circuit	136
Ex. 4-2	Solving AC Circuits Using the Power Triangle Method	141
	DISCUSSION.....	141
	Solving ac circuits using the power triangle method	141
	Example	143
	PROCEDURE	145
	Setup and connections	145
	Solving an ac circuit using the power triangle method	147
	Appendix A Equipment Utilization Chart.....	155
	Appendix B Glossary of New Terms	157
	Appendix C Impedance Table for the Load Modules	161
	Appendix D Vectorial Calculations	163
	Vectorial division.....	164
	Vectorial multiplication.....	165
	Appendix E Circuit Diagram Symbols	167
	Index of New Terms.....	173
	Bibliography	175
	We Value Your Opinion!.....	177

Preface

The production of energy using renewable natural resources such as wind, sunlight, rain, tides, geothermal heat, etc., has gained much importance in recent years as it is an effective means of reducing greenhouse gas (GHG) emissions. The need for innovative technologies to make the grid smarter has recently emerged as a major trend, as the increase in electrical power demand observed worldwide makes it harder for the actual grid in many countries to keep up with demand. Furthermore, electric vehicles (from bicycles to cars) are developed and marketed with more and more success in many countries all over the world.

To answer the increasingly diversified needs for training in the wide field of electrical energy, Lab-Volt developed the Electric Power Technology Training Program, a modular study program for technical institutes, colleges, and universities. The program is shown below as a flow chart, with each box in the flow chart representing a course.

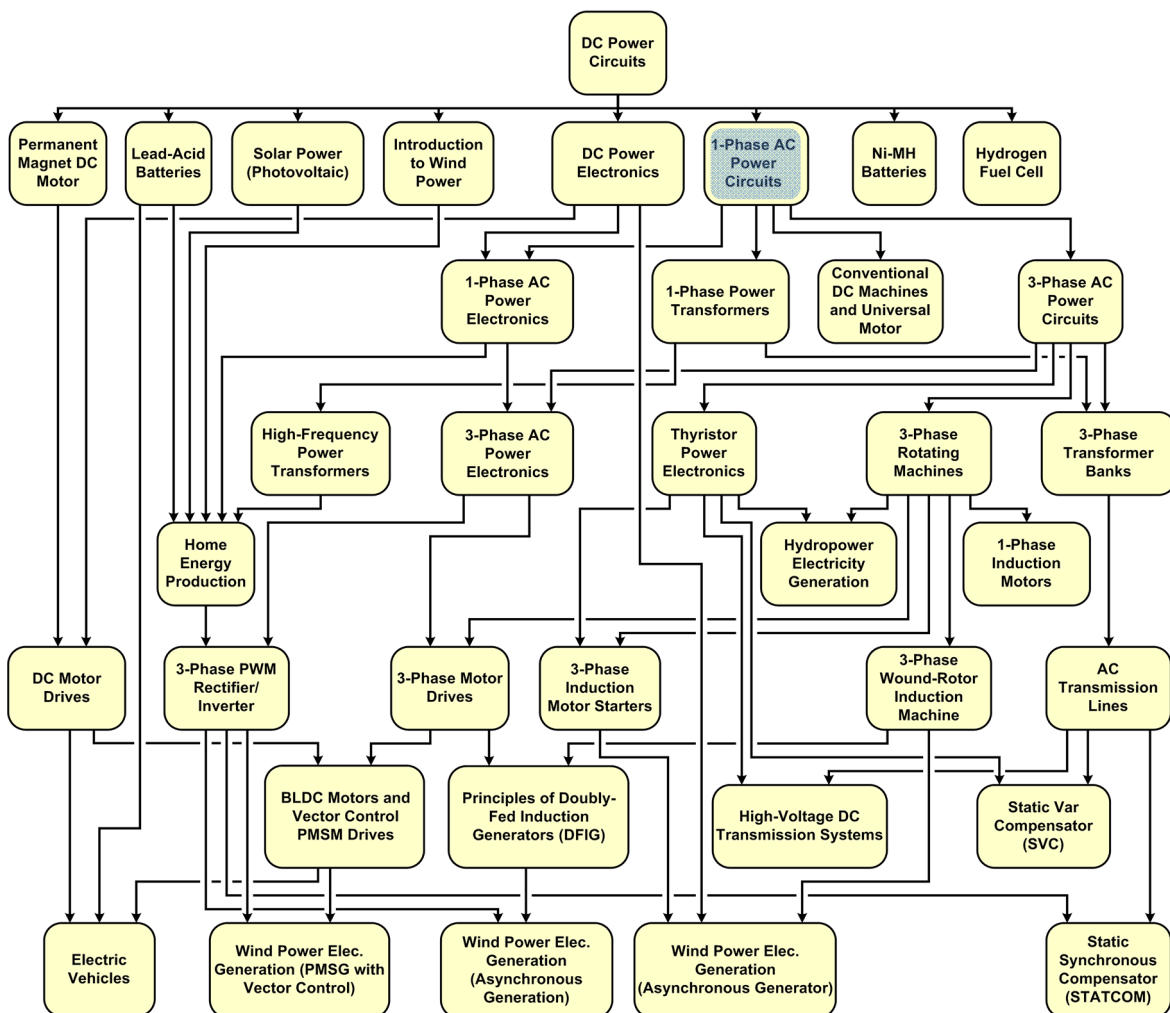

The Lab-Volt Electric Power Technology Training Program.

Preface

The program starts with a variety of courses providing in-depth coverage of basic topics related to the field of electrical energy such as ac and dc power circuits, power transformers, rotating machines, ac power transmission lines, and power electronics. The program then builds on the knowledge gained by the student through these basic courses to provide training in more advanced subjects such as home energy production from renewable resources (wind and sunlight), large-scale electricity production from hydropower, large-scale electricity production from wind power (doubly-fed induction generator [DFIG], synchronous generator, and asynchronous generator technologies), smart-grid technologies (SVC, STATCOM, HVDC transmission, etc.), storage of electrical energy in batteries, and drive systems for small electric vehicles and cars.

About This Manual

Alternating-current (ac) power systems began to develop quickly in the late 19th century, following key developments in the field of electricity, mainly the invention of the polyphase system of electrical distribution by scientist Nikola Tesla, and the development of mathematical analysis of electricity by Charles Steinmetz, James Clerk Maxwell, and William Thomson (Lord Kelvin).

The main advantage of ac power systems is that high amounts of power can be transmitted efficiently over long transmission lines. Step-up transformers are used at the ac power generating point to increase the voltage and decrease the current. The power lost as heat in the resistance of a transmission line increases by the square of the current. Therefore, ac power is transmitted at very high voltages and low currents to reduce power losses in the line resistance to a minimum. At the receiving end of the line, step-down transformers reduce the voltage and increase the current to levels compatible with residential or industrial equipment.

Today ac power systems are used throughout the world for driving motors and powering electric equipment in transport, heating, lighting, communications, and computation.

This course, *Single-Phase AC Power Circuit*, introduces students to the fundamentals of alternating current, such as the sine wave, period and frequency, phase angle and phase shift, instantaneous and average power, etc. Students then become familiar with the inductor and capacitor. The course continues with more advanced topics such as the impedance, active power, reactive power, apparent power, and power triangle. The course concludes by teaching students how to solve ac power circuits using the impedance calculation method or the power triangle method.



Most lighting in urban centers is powered using single-phase alternative current.

About This Manual

Safety considerations



Safety symbols that may be used in this manual and on the Lab-Volt equipment are listed in the Safety Symbols table at the beginning of the manual.

Make sure that you are wearing appropriate protective equipment when performing the tasks requested in hands-on exercises. You should never perform a task if you have any reason to think that a manipulation could be dangerous for you or your teammates.

Reference Material

Refer to the manual titled *Electrical Machines, Drives, and Power Systems* from Wildi, Theodore, as reference textbook.

Prerequisite

To perform the exercises in this manual you should have completed the manual titled *DC Power Circuits* (Lab-Volt P/N 86350).

Systems of units

The values of measured parameters are expressed using the SI system of units followed by the values expressed in the U.S. customary system of units (in parentheses).

Alternating Current

UNIT OBJECTIVE

When you have completed this unit, you will be familiar with alternating current (ac). You will be able to define, calculate, and measure the various parameters of voltage and current sine waves: amplitude, effective or root-mean-square (rms) value, instantaneous value, period, and frequency. You will know how to measure the average power dissipated in a resistive load connected to an ac power source.

DISCUSSION OUTLINE

The Discussion of Fundamentals covers the following points:

- DC circuits versus ac circuits
- Alternating current (ac) and ac voltage
- Alternating current and ac voltage supplied by public power distribution utilities
- Safety rules

DISCUSSION OF FUNDAMENTALS

DC circuits versus ac circuits

In a direct-current (dc) circuit, the current flows only in one direction: from the positive (+) terminal of the dc source to the negative (–) terminal (conventional current direction). This is shown in Figure 1-1a.

In an alternating-current (ac) circuit, the current continuously switches direction because the voltage at the ac source terminals continuously changes polarity with time, alternating between positive and negative. This is shown in Figure 1-1b.

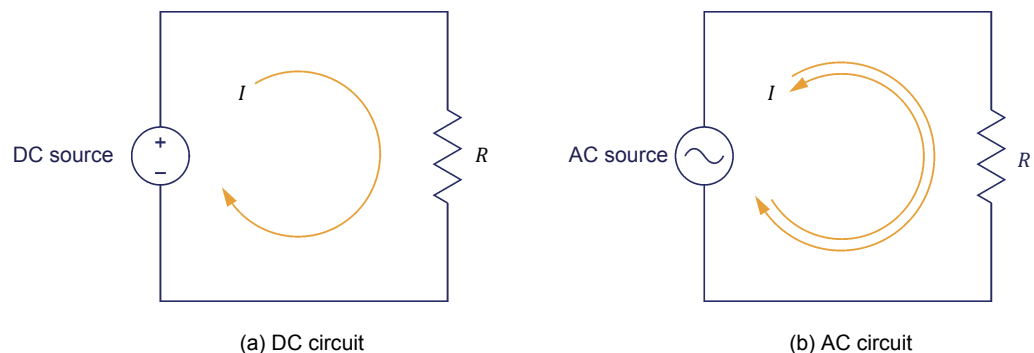

Figure 1-1. DC circuit versus ac circuit.

Alternating current (ac) and ac voltage

Alternating current (ac) changes direction many times each second. Similarly, alternating-current voltage changes polarity many times each second. Figure 1-2 shows three different ac waveforms: a sine wave, a rectangular wave, and a triangular wave.

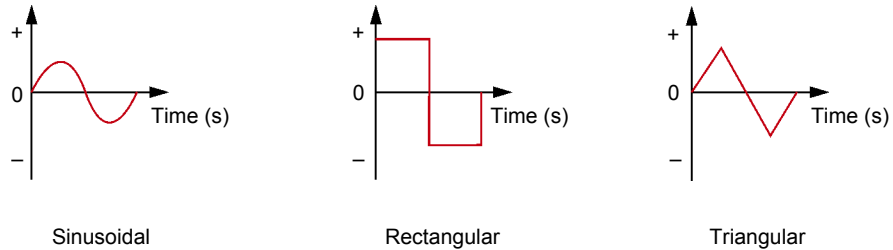

Figure 1-2. Alternating-current (ac) waveforms.

Alternating current and ac voltage supplied by public power distribution utilities

Alternating current is the type of current supplied by public power utilities to houses and factories. Alternating current is produced by rotating machines such as alternators and ac generators. The alternating current and ac voltage produced by alternators and ac generators are both sinusoidal. Figure 1-3 shows a sinusoidal voltage or current graphed over time. The figure illustrates the following characteristics:

- The voltage or current periodically changes from one polarity to the other.
- The value of the voltage or current continuously changes with time. This value passes from a positive maximum to a negative maximum, then to another positive maximum, and so on. The value of the voltage or current changes rapidly near zero values and slowly at the positive and negative maxima.
- The portion of the wave during which the voltage or current is of positive (+) polarity is called the **positive half-wave**. The portion of the wave during which the voltage or current is of negative (–) polarity is called the **negative half-wave**.
- The duration of a positive half-wave, plus the duration of the subsequent negative half-wave form a complete cycle of the waveform.

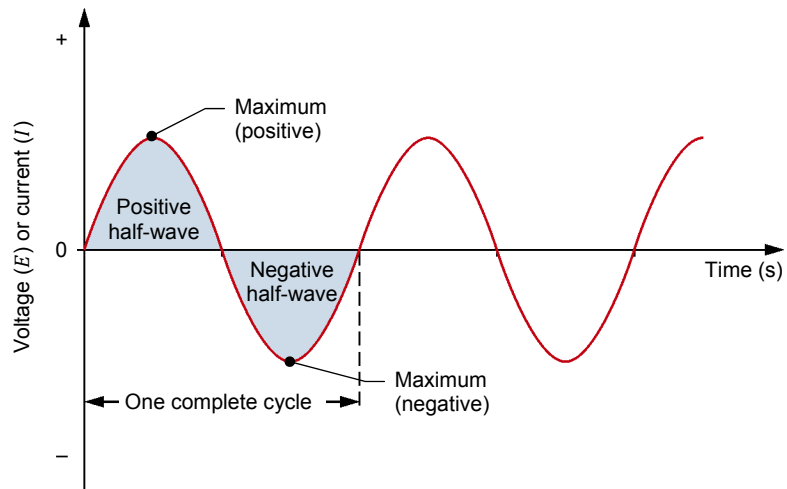

Figure 1-3. Typical sine wave of voltage or current graphed over time.

The number of times that a cycle repeats every second is called the **frequency** f . The frequency is expressed in hertz (Hz). In North America, the frequency of the current supplied by public power distribution utilities is 60 Hz. In Europe, Asia, Africa, Russia, the Middle-East, and Australia, this frequency is usually 50 Hz. In South America and Japan, this frequency can be either 50 Hz or 60 Hz.

As mentioned earlier, ac waves can have shapes other than sinusoidal, for instance rectangular or triangular. However, theory and practice have shown that sine waves are best suited for powering electrical machinery. Sine waves provide the highest efficiency from transformers, motors, and generators, and also result in a quieter operation. Sine waves also simplify voltage and current calculations in electrical circuits. For example, the value of a sinusoidal current or voltage at any instant of the cycle can be calculated by using the sine mathematical function.

Safety rules

Observe the following safety rules when using electrical equipment:

1. Always make sure that the ac power source is disabled when connecting or disconnecting leads or components.
2. Never leave any electrical lead unconnected. Touching the unconnected end of a lead while the ac power source is enabled could give you an electric shock. A short circuit could also occur if the unconnected end of a lead touches a conducting surface.
3. When connecting an electrical circuit, make sure that the contact terminals are free of dirt, oil, and water. Dirt and oil are insulators and impair the connection between two components. Water is a conductor and might make a connection where it is not wanted.

The Sine Wave

EXERCISE OBJECTIVE

When you have completed this exercise, you will be familiar with the notion of a sine wave and how it can be expressed as a phasor rotating around the center of a circle. You will also be familiar with the different parameters of a sine wave, such as its period, frequency, amplitude, and instantaneous values. You will see how to express current and voltage in ac power circuits as sine waves. You will be introduced to the concept of rms (effective) values and know how to calculate the rms value from the amplitude of a voltage or current sine wave.



The hands-on exercises in this manual require you to be familiar with the Lab-Volt computer-based instruments. Refer to the user guides titled “Data Acquisition and Control System” (86716-E0) and “Computer-Based Instruments for EMS” (86718-E0) to become familiar with the operation and use of the Lab-Volt computer-based instruments.

DISCUSSION OUTLINE

The Discussion of this exercise covers the following points:

- Relationship between a rotating phasor and a sine wave
- Period and frequency of a sinusoidal voltage or current
- Amplitude and instantaneous value of a sinusoidal voltage or current
- Effective or root-mean-square (rms) value and heating capacity
- Effective (rms) value of a sinusoidal voltage or current

DISCUSSION

Relationship between a rotating phasor and a sine wave

A direct relationship exists between circular motion and a sine wave. Thus, a sinusoidal voltage or current can be graphed using the vertical-axis deflection as a function of the angular position α of a rotating **phasor**. A phasor is a **vector** having its origin at the center (0, 0) of a cartesian plane. Each cycle of a sinusoidal signal corresponds to one complete revolution (one turn) of the phasor around the circle, which is equal to 360° or 2π radians. Figure 1-4 shows a sine wave graphed using the vertical-axis deflection as a function of the angular position of a rotating phasor.

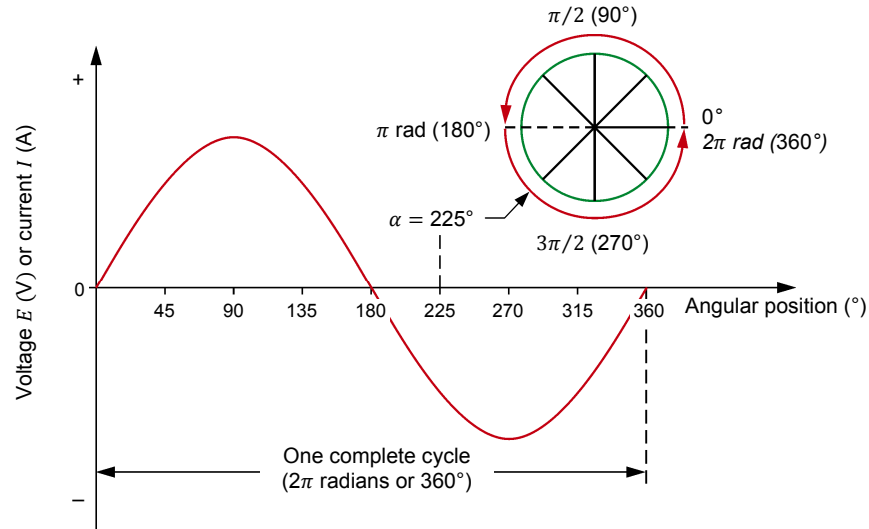

Figure 1-4. Sine wave graphed using the vertical-axis deflection as a function of the angular position of a rotating phasor.

Figure 1-5 shows an example in which a phasor is rotating counterclockwise around the center of a circle at a constant velocity. As the phasor is rotating, the vertical distance between the tip of the phasor and the horizontal axis of the circle continuously varies. A graphical projection of the distance value d , on the XY-plane as a function of the angular position α gives a sine wave. The following can be observed in Figure 1-5:

- Initially, the phasor is at 0° (horizontal position), so the vertical distance d between the phasor and the horizontal axis is null.
- As the phasor is rotating from 0° to 90° , the vertical distance d between the tip of the phasor and the horizontal axis gradually increases from zero to a maximum positive (peak) value.
- As the phasor is rotating from 90° to 180° , the vertical distance d between the tip of the phasor and the horizontal axis gradually decreases from the maximum positive value to zero.
- As the phasor is rotating from 180° to 270° , the vertical distance d between the tip of the phasor and the horizontal axis increases from zero to a maximum negative (peak) value.
- As the phasor is rotating from 270° to 360° , the vertical distance d between the tip of the phasor and the horizontal axis decreases from the maximum negative value to zero.

One complete revolution of the phasor (i.e., 360°) corresponds to one complete cycle of the sine wave.

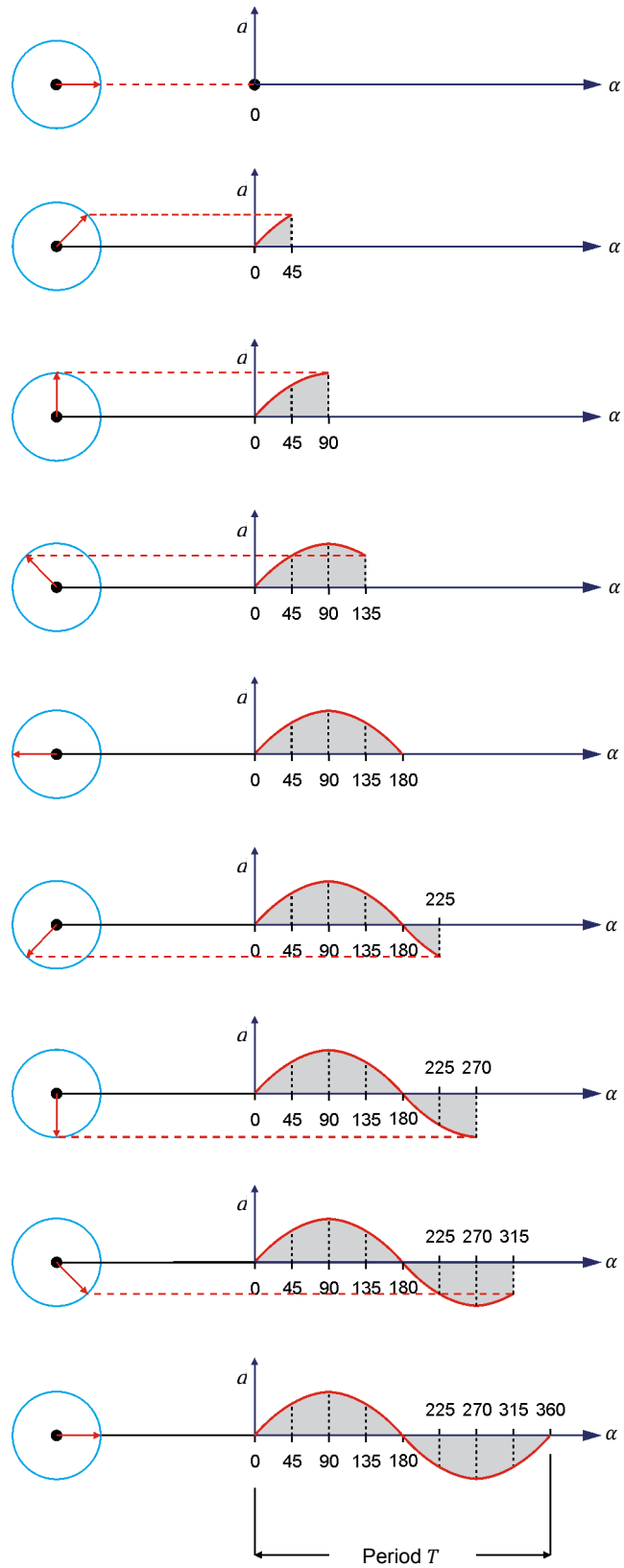

Figure 1-5. Relationship between a rotating phasor and a sine wave.

Period and frequency of a sinusoidal voltage or current

The time required for one complete cycle of a sine wave to occur is called the **period** T . The number of cycles that occur in one second is called the frequency f of the sine wave. Frequency is measured in hertz (Hz), 1 Hz being equal to 1 cycle per second.

The equation used for calculating the frequency is:

$$f = \frac{1}{T} \quad (1-1)$$

where f is the frequency of the sine wave, expressed in hertz (Hz) or cycles per second (c/s).

T is the period of the sine wave, expressed in seconds (s).

The period is the reciprocal of the frequency:

$$T = \frac{1}{f} \quad (1-2)$$

In a 60 Hz ac power system, the cycle of the sinusoidal voltage and current repeats itself 60 times per second. Therefore, the period T of one cycle is $1/60 \text{ s} = 16.7 \text{ ms}$.

In a 50 Hz ac power system, the cycle of the sinusoidal voltage and current repeats itself 50 times per second. Therefore, the period T of one cycle is $1/50 \text{ s} = 20 \text{ ms}$.

Amplitude and instantaneous value of a sinusoidal voltage or current

The equation of a sine wave is:

$$a(t) = A \sin(\alpha(t)) = A \sin(\omega t) \quad (1-3)$$

where $a(t)$ is the instantaneous value of the sine wave at a given instant t .

A is the amplitude of the sine wave.

$\alpha(t)$ is the angular position of the sine wave at a given instant t , expressed in degrees ($^\circ$).

ω is the angular velocity, expressed in radians per second (rad/s) of the rotating phasor. $\omega = 2\pi f$.

t is the time, expressed in seconds (s).

The **amplitude** A is the maximum value reached by the sine wave during its cycle. The maximum value is the same for both the positive and negative half-waves of the cycle, except for the polarity which changes from positive (+) to negative (–).

The general equation of a sine wave can be used to describe a sinusoidal voltage mathematically:

$$E(t) = E_{Max.} \sin(\alpha(t)) = E_{Max.} \sin(\omega t) \quad (1-4)$$

where $E(t)$ is the instantaneous value of the voltage at a given instant t of the cycle, expressed in volts (V).
 $E_{Max.}$ is the amplitude of the sinusoidal voltage, expressed in volts (V).

For example, if the amplitude (maximum voltage) of the voltage $E_{Max.}$ is 100 V, the instantaneous value of the voltage $E(t)$ at angular position $\alpha(t) = 45^\circ$ is:

$$E(t) = 100 \text{ V} \sin 45^\circ = 70.7 \text{ V}$$

Figure 1-6 shows the voltage sine wave graph resulting from Equation (1-4).

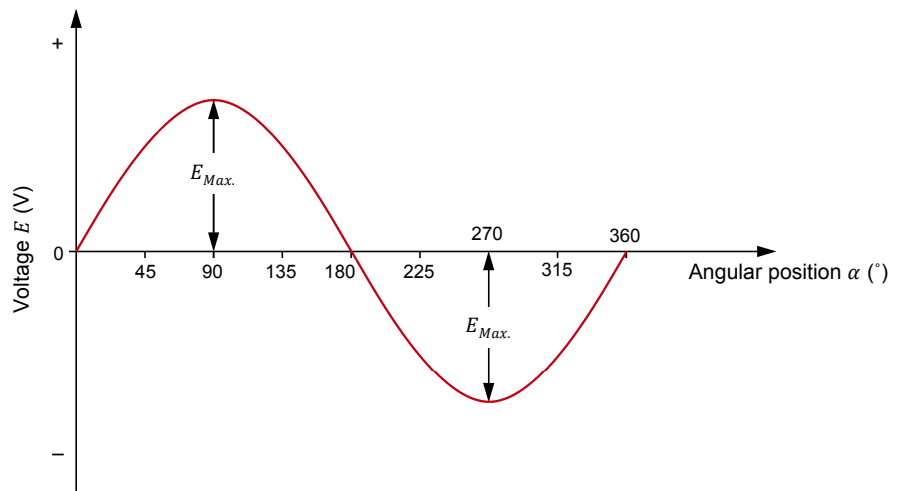

Figure 1-6. Voltage sine wave.

Similarly, the general equation of a sine wave can be used to describe a sinusoidal current mathematically:

$$I(t) = I_{Max.} \sin(\alpha(t)) = I_{Max.} \sin(\omega t) \quad (1-5)$$

where $I(t)$ is the instantaneous value of the current at a given instant t of the cycle, expressed in amperes (A).
 $I_{Max.}$ is the amplitude of the sinusoidal current, expressed in amperes (A).

Effective or root-mean-square (rms) value and heating capacity

The effective (rms) value of an ac voltage is related to the heat produced by a resistive element when supplied with this voltage. For example, consider an ac voltage having an amplitude E_{Max} applied across a load resistor. The applied voltage causes current to flow through the resistor, which has the effect of increasing the resistor's temperature until it stabilizes to a certain level (equilibrium temperature). The rms or effective value of this ac voltage can be found by applying a dc voltage across the load resistor, and adjusting the dc voltage until the resistor stabilizes to the equilibrium temperature previously reached with the ac voltage. The value of this dc voltage corresponds to the rms or effective value of the ac voltage.

Effective (rms) value of a sinusoidal voltage or current

The effective (rms) value of a sinusoidal voltage E_{RMS} is calculated as follows:

$$E_{RMS} = \frac{E_{Max.}}{\sqrt{2}} = 0.707 \cdot E_{Max.} \quad (1-6)$$

Similarly, the effective (rms) value of a sinusoidal current I_{RMS} is calculated as follows:

$$I_{RMS} = \frac{I_{Max.}}{\sqrt{2}} = 0.707 \cdot I_{Max.} \quad (1-7)$$

For example, the effective (rms) value of a sinusoidal voltage having an amplitude $E_{Max.}$ of 100 V is 70.7 V ($0.707 \cdot 100$ V). This means that a sine-wave voltage having an amplitude $E_{Max.}$ of 100 V has the same heating capacity as a dc voltage of 70.7 V.

Figure 1-7 shows the rms value E_{RMS} of a voltage sine wave in comparison to its amplitude $E_{Max.}$ value.

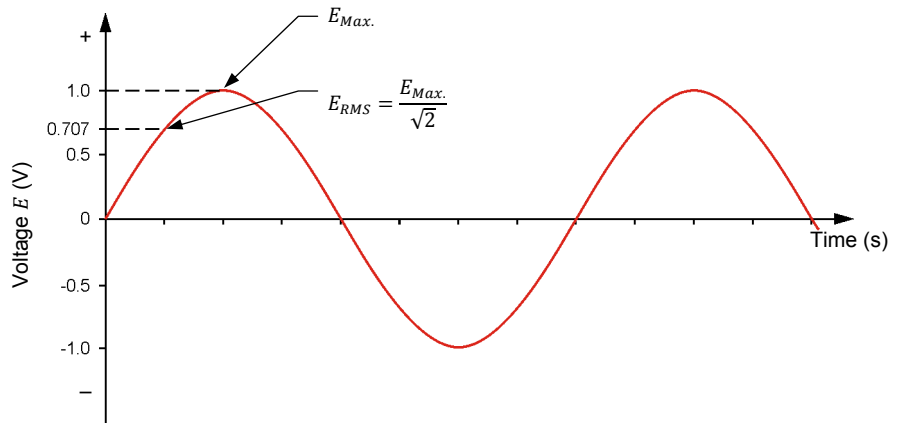

Figure 1-7. Effective, or root-mean-square (rms), value of a sinusoidal voltage.

Standard instruments used to measure ac voltage and current normally indicate the effective (rms) value directly on their display. The rms values of voltage and current are used to calculate electrical power in ac power circuits. The reasoning behind rms values will be explained in more detail in Exercise 1-3.

PROCEDURE OUTLINE

The Procedure is divided into the following sections:

- Setup and connections
- Measuring voltage, current, and frequency in an ac circuit
- Relationship between frequency and period
- Measuring voltage, current, and frequency in a series ac circuit

PROCEDURE



High voltages are present in this laboratory exercise. Do not make or modify any banana jack connections with the power on unless otherwise specified.

Setup and connections

In this section, you will connect an ac circuit containing a resistor and set up the equipment to measure the circuit current and voltage using the LVDAC-EMS software. You will also determine the relationship between the frequency f of a sine wave and its period T .

1. Refer to the Equipment Utilization Chart in Appendix A to obtain the list of equipment required to perform this exercise.

Install the required equipment in the [Workstation](#).

2. Make sure that the main power switch on the **Four-Quadrant Dynamometer/Power Supply** is set to the **O** (off) position, then connect its **Power Input** to an ac power outlet.

Connect the **Power Input** of the **Data Acquisition and Control Interface** to a 24 V ac power supply. Turn the 24 V ac power supply on.

3. Connect the USB port of the **Data Acquisition and Control Interface** to a USB port of the host computer.

Connect the USB port of the **Four-Quadrant Dynamometer/Power Supply** to a USB port of the host computer.

4. Turn the **Four-Quadrant Dynamometer/Power Supply** on, then set the **Operating Mode** switch to **Power Supply**. This setting allows the **Four-Quadrant Dynamometer/Power Supply** to operate as a power supply.

5. Turn the host computer on, then start the **LVDAC-EMS** software.

In the **LVDAC-EMS Start-Up** window, make sure that the **Data Acquisition and Control Interface** and the **Four-Quadrant Dynamometer/Power Supply** are detected. Make sure that the **Computer-Based Instrumentation** function for the **Data Acquisition and Control Interface** is available. Select the network voltage and frequency that correspond to the voltage and frequency of your local ac power network, then click the **OK** button to close the **LVDAC-EMS Start-Up** window.

6. Set up the circuit shown in Figure 1-8. Note the symbol used to indicate a variable-voltage ac source in this circuit. In order to obtain the resistance value indicated next to the resistor in Figure 1-8, make the necessary switch settings on the **Resistive Load**.



*Throughout this manual, keep in mind that the resistance values shown in the figures are equivalent resistances. To obtain a given resistance value with the **Resistive Load**, you may need to connect two or more resistors of a resistor section in parallel as well as to interconnect resistor sections in parallel. Appendix C lists the switch settings to implement on the **Resistive Load** in order to obtain various resistance values.*

Use inputs **I1** and **E1** of the **Data Acquisition and Control Interface** to measure the source current I_S , and the voltage across the resistor E_R .

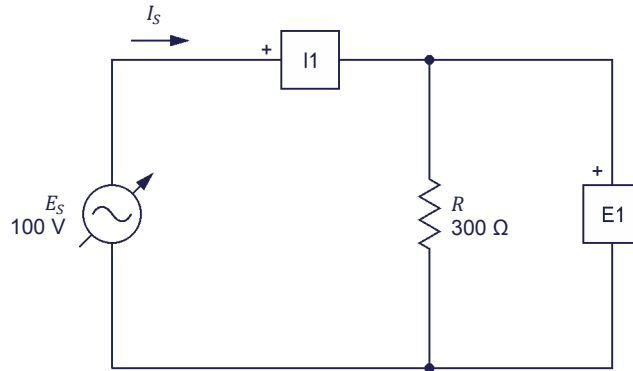

Figure 1-8. AC circuit containing a resistor.

7. In **LVDAC-EMS**, open the **Four-Quadrant Dynamometer/Power Supply** window, then make the following settings:
 - Set the **Function** parameter to **AC Power Source**. This setting makes the internal power source operate as an ac power source (i.e., a source producing a sinusoidal voltage).
 - Make sure that the **Voltage Control** parameter is set to **Knob**. This allows the ac power source to be controlled manually.
 - Set the **No Load Voltage** parameter to 100 V. This sets the no-load effective (rms) voltage of the ac power source to 100 V.
 - Set the **Frequency** parameter to the frequency of your local ac power network. This makes the frequency of the ac power source equal to the frequency of your local ac power network.
 - Leave the other parameters set as they are.
 - Notice that the **Status** parameter is set to **Stopped**. This indicates that the ac power source is disabled (i.e., it produces no output voltage). The ac power source will be enabled in the next section of the procedure.

Measuring voltage, current, and frequency in an ac circuit

In this section, you will measure the rms values of the voltage and current waveforms in the ac circuit. You will then measure the amplitude of these waveforms and calculate the corresponding rms values. You will compare the measured and calculated rms values. Finally, you will compare the shapes of the voltage and current waveforms to confirm that they reach their maximum and null values at the same time.

8. In the **Four-Quadrant Dynamometer/Power Supply** window, enable the ac power source (i.e., set the **Status** parameter to **Started** or click on the **Start/Stop** button). The ac power source now delivers power to the load, R .



In this manual, for brevity purposes, the rms value is implied in the denomination of most parameters that are commonly measured as rms values (e.g., E_S , I_S , E_R , mean $E_{S,rms}$, $I_{S,rms}$, $E_{R,rms}$). A complementary suffix, such as rms or max, is added only when extra clarity and precision are necessary, such as in equations, for example.

9. In **LVDAC-EMS**, open the **Metering** window. Set meters **E1** and **I1** to measure the rms values of the resistor voltage E_R and source current I_S .



*When doing measurements using either the **Metering** window, **Oscilloscope**, or **Phasor Analyzer**, always select the continuous refresh mode. This enables updated data to be seen on screen at all times.*

In the **Four-Quadrant Dynamometer/Power Supply** window, readjust the value of the **No Load Voltage** parameter so that the ac power source voltage E_S (indicated by meter **E1** in the **Metering** window) is equal to 100 V.

Record below the measured values of the resistor voltage E_R and source current I_S (meters **E1** and **I1**, respectively).

Resistor voltage $E_R = \underline{\hspace{2cm}}$ V

Source current $I_S = \underline{\hspace{2cm}}$ A

10. In **LVDAC-EMS**, open the **Oscilloscope** and display E_R (input **E1**) and I_S (input **I1**) on channels 1 and 2, respectively. If necessary, set the time base to display at least two cycles of the sine waves.



*In the **Oscilloscope** settings, you can enable the filtering option to improve the regularity of the displayed waveforms.*

11. On the **Oscilloscope**, select the continuous refresh mode. Change the vertical scales so as to be able to measure the amplitude of the resistor voltage E_R and source current I_S . Record the measured values below.



*The rms value, average value, and frequency of the signals applied to the input channels of the **Oscilloscope** are displayed below the **Oscilloscope** screen.*



*To obtain an accurate measurement, you can use the horizontal cursors of the **Oscilloscope** to measure the amplitude of the voltage and current.*

Resistor voltage $E_{R,max.} = \underline{\hspace{2cm}}$ V

Source current $I_{S,max.} = \underline{\hspace{2cm}}$ A

12. Calculate the rms values of E_R and I_S from the voltage and current amplitudes measured in the previous step.

Resistor voltage $E_R = \underline{\hspace{2cm}}$ V

Source current $I_S = \underline{\hspace{2cm}}$ A

13. Compare the rms values obtained in the previous step with the rms values indicated by the meters (as recorded in step 9). Are they approximately the same?

Yes No

14. Compare the source current waveform with the resistive load voltage waveform. Are they both sine waves?

Yes No

15. What is the instantaneous value of the resistor voltage E_R at the angular position 225° ?

Resistor voltage E_R at $225^\circ = \underline{\hspace{2cm}}$ V

16. Do the waveforms of the resistor voltage E_R and source current I_S reach the maximum positive value, null values, and maximum negative value at the same time?

Yes No



When waveforms reach the maximum and null values at the same time, the waveforms are said to be in phase, which means there is no phase shift between them. This is covered in more detail in Exercise 1-2.

Relationship between frequency and period

In this section, you will determine the relationship between the frequency f and the period T of a sine wave. You will do so by setting the frequency of the ac power source to various values and measuring each time the period of the voltage waveform. You will then calculate the frequency from each measured period and compare it with the ac power source frequency.

17. In the **Four-Quadrant Dynamometer/Power Supply** window, set the **Frequency** parameter to 40 Hz. This changes the frequency of the ac power source to 40 Hz.
18. Using the **Oscilloscope**, measure the period T of the waveform of the resistor voltage E_R . Record the period value in the corresponding cell of Table 1-1 below.



To obtain an accurate measurement, use the vertical cursors of the Oscilloscope to measure the time interval between two points on a waveform.

Table 1-1. Relationship between the frequency f and period T .

Source frequency (Hz)	Period T (ms)	Calculated source frequency (Hz)
40		
50		
60		
70		

19. Repeat steps 17 and 18 for each ac power source frequency indicated in Table 1-1. Record your results in the corresponding cells.
20. Based on the measured period values in Table 1-1, calculate the resulting frequencies. Record your calculated source frequency values in the corresponding row of Table 1-1.
21. Compare the ac power source frequency values to your calculated source frequency values. Are they the same?

Yes No
22. Does this confirm the relationship ($f = 1/T$) between the frequency and period?

Yes No

Measuring voltage, current, and frequency in a series ac circuit

In this section, you will calculate the voltage and current rms values in a circuit containing two resistors in series. You will confirm that Ohm's law applies to ac power circuits by measuring the voltage and current rms values and comparing them with those you calculated. You will also confirm Kirchhoff's law by verifying that $E_{R1} + E_{R2} = E_S$. Finally, you will verify that both the current and voltage waveforms are in phase with each other.

23. In the **Four-Quadrant Dynamometer/Power Supply** window, disable the ac power source (i.e., set the *Status* parameter to *Stopped* or click on the *Start/Stop* button).
24. Set up the circuit shown in Figure 1-9. To obtain the resistor arrangement of Figure 1-9, make the necessary connections and switch settings on the Resistive Load (refer to Appendix C if necessary). Use inputs *I1*, *E1*, *E2*, and *E3* of the **Data Acquisition and Control Interface** to measure the source current I_S , voltage E_{R1} , voltage E_{R2} , and source voltage E_S , respectively.

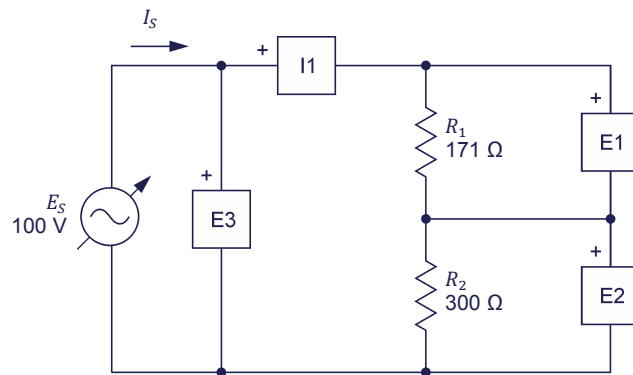

Figure 1-9. AC circuit containing two resistors connected in series.

25. Calculate the equivalent resistance $R_{Equiv.}$ of the circuit resistors. Using Ohm's law, you will then be able to calculate the rms source current I_S .

Equivalent resistance $R_{Equiv.} = R_1 + R_2 = \underline{\hspace{2cm}} \Omega$

Source current $I_S = \frac{E_S}{R_{Equiv.}} = \underline{\hspace{2cm}} \text{ A}$

26. Calculate the resistor voltages E_{R1} and E_{R2} across each resistor by using the source current I_S value obtained in the previous step.

Resistor voltage $E_{R1} = I_S \cdot R_1 = \underline{\hspace{2cm}} \text{ V}$

Resistor voltage $E_{R2} = I_S \cdot R_2 = \underline{\hspace{2cm}} \text{ V}$

27. In the **Four-Quadrant Dynamometer/Power Supply** window, set the **Frequency** parameter back to the frequency of your local ac power network, then enable the ac power source.

In the **Four-Quadrant Dynamometer/Power Supply** window, readjust the value of the **No Load Voltage** parameter so that the ac power source voltage E_S (indicated by meter **E3** in the **Metering** window) is equal to 100 V.

28. In the **Metering** window, set meter **E2** to measure the rms value of the resistor voltage E_{R2} . Record voltages E_{R1} and E_{R2} and the source current I_S .

Resistor voltage $E_{R1} = \underline{\hspace{2cm}}$ V

Resistor voltage $E_{R2} = \underline{\hspace{2cm}}$ V

Source current $I_S = \underline{\hspace{2cm}}$ A

29. Compare voltages E_{R1} and E_{R2} measured in the previous step with the voltages calculated in step 26. Are they approximately the same?

Yes No

Is the sum of the voltages across the resistors ($E_{R1} + E_{R2}$) equal to the source voltage E_S ?

Yes No

30. Compare the source current I_S measured in step 28 with the source current I_S calculated in step 25. Are they approximately the same?

Yes No

31. Calculate and compare the ratio of the voltages measured across the resistors with the ratio of the resistor values. Are they approximately the same?

$$\frac{E_{R1}}{E_{R2}} = \underline{\hspace{2cm}} \qquad \frac{R_1}{R_2} = \underline{\hspace{2cm}}$$

Yes No

32. From the results obtained in the previous steps, can ac circuits be solved by using the same fundamental rules as those used with dc circuits, which are Ohm's law, Kirchhoff's voltage and current laws, and the formulas used to calculate the equivalent resistance?

Yes No

33. On the **Oscilloscope**, display the voltage E_{R1} (input **E1**), voltage E_{R2} (input **E2**), and source current I_S (input **I1**) on channels 1, 2, and 3, respectively. Make sure the time base is set so as to display as least two cycles of the sine waves.
34. Compare the waveforms displayed on the **Oscilloscope**. Do the source current waveform and resistor voltage waveforms reach the maximum positive value, null values, and maximum negative value at the same time, indicating that they are in phase?
- Yes No
35. In the **Four-Quadrant Dynamometer/Power Supply** window, disable the ac power source.
36. Close **LVDAC-EMS**, then turn off all the equipment. Disconnect all leads and return them to their storage location.

CONCLUSION

In this exercise, you were introduced to the sine wave and the way to express a sine wave using a phasor rotating around the center of a circle. You learned how to calculate the different parameters of a sine wave, such as the period, the frequency, the amplitude, and the instantaneous value. You were introduced to the concept of rms value and learned how to calculate the rms value from the amplitude of a sine wave.

REVIEW QUESTIONS

1. A voltage sine wave has an amplitude of 200 V. Calculate its rms value.

2. The period of a sine wave is 0.02 s. Calculate its frequency.

3. What is the effect on the cycle of a sine wave of increasing the frequency?

4. Which angular position (in degrees as well as in radians) on a circle corresponds to the positive maximum value of a voltage sine wave whose cycle begins at the origin?

5. What is the difference between the amplitude and rms value of a voltage sine wave?

Phase Angle and Phase Shift

EXERCISE OBJECTIVE When you have completed this exercise, you will know what a phase angle is and how the phase angle modifies the initial displacement of a sine wave. You will be able to determine the phase shift between two sine waves, either by comparing their phase angles or by determining their separation in time. You will also know how to distinguish a leading phase shift from a lagging phase shift.

DISCUSSION OUTLINE The Discussion of this exercise covers the following points:

- Phase angle
- Phase shift

DISCUSSION

Phase angle

As you have seen in Exercise 1-1, the graphical representation of a sine wave can be expressed by the following equation:

$$a(t) = A \sin(\omega t) \quad (1-8)$$

where $a(t)$ is the instantaneous value of the sine wave at a given instant t .

A is the amplitude of the sine wave.

ω is the angular velocity, expressed in radians per second (rad/s).

t is the time, expressed in seconds (s).

This equation assumes that the sine wave cycle begins at the exact moment when $t = 0$ (as is shown in Figure 1-10). As you will see later, this is not always the case. To represent the initial position of the sine wave, the notion of **phase angle** θ is introduced in the equation below:

$$a(t) = A \sin(\omega t + \theta) \quad (1-9)$$

where θ is the phase angle of the sine wave, expressed in degrees ($^\circ$) or radians (rad).

From Equation (1-9), it is easy to observe that the initial value (i.e., the value at $t = 0$) of the sine wave depends entirely on the phase angle θ because the term ωt equals 0 at $t = 0$. In other words, the phase angle θ determines by how much the value of a sine wave differs from 0 at time $t = 0$, and thus, the position in time of the sine wave.

Figure 1-10 shows a sine wave with a phase angle θ of 0° . The initial value of this sine wave is 0 because $A \sin(\omega \cdot 0 + 0) = 0$. This sine wave is identical to those seen in Exercise 1-1, as a phase angle value of 0° was implied by the absence of θ in the equations given in Exercise 1-1.

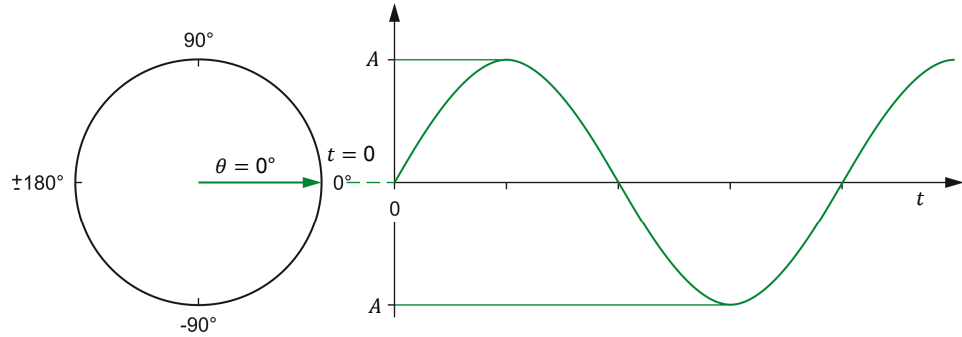

Figure 1-10. Sine wave with a phase angle θ of 0° .

Figure 1-11 shows a sine wave with a phase angle θ of 45° . As you can see from the figure, a positive phase angle (0° to 180°) results in the sine wave having a positive instantaneous value when $t = 0$. In other words, a positive phase angle shifts the sine wave toward the left, i.e., advances the sine wave in time.

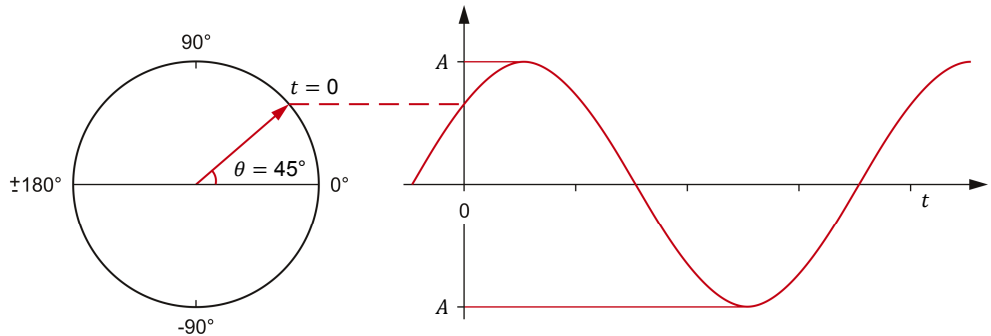

Figure 1-11. Sine wave with a phase angle θ of 45° .

Figure 1-12 shows a sine wave with a phase angle θ of -60° . A negative phase angle (0° to -180°) results in the sine wave having a negative instantaneous value when $t = 0$. In other words, a negative phase angle shifts the sine wave toward the right, i.e., delays the sine wave in time.

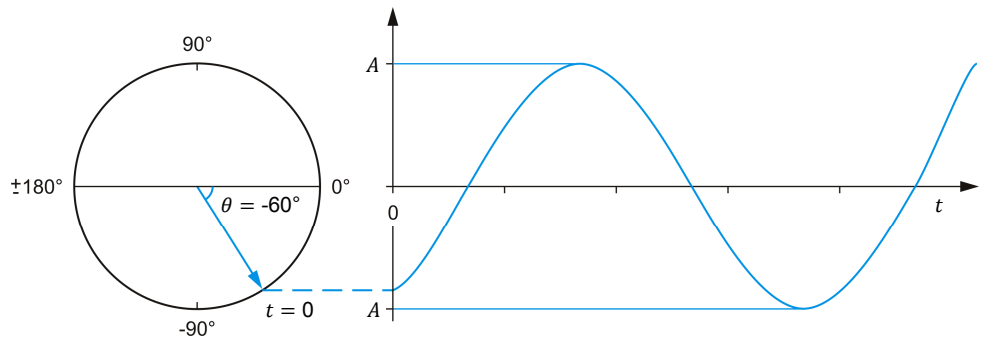

Figure 1-12. Sine wave with a phase angle θ of -60° .

Figure 1-10 to Figure 1-12 also show the phasor representations of the sine waves at time $t = 0$. Notice that, in each figure, the vertical distance between the tip of the rotating phasor representing the sine wave matches the instantaneous value of the sine wave at $t = 0$.

Phase shift

When comparing two sine waves having the same frequency, the difference between their respective phase angles is called the **phase shift** and is expressed in degrees ($^\circ$) or radians (rad). The magnitude of the phase shift indicates the extent of separation in time between the two sine waves, while the polarity of the phase shift (positive or negative) indicates the relationship in time between the two sine waves (**leading** or **lagging**). The sine wave amplitude value has no effect on the phase shift, as it does not change the period nor the frequency of the sine wave. Sine waves with different frequencies and, as an extension, different periods, cannot be compared by using their phase angles as their cycles do not correspond.

The phase shift between two sine waves is expressed as an angle representing a portion of a complete cycle of the sine waves. One of the two sine waves is used as the reference for phase shift measurements. The phase shift is calculated by subtracting the phase angle $\theta_{Ref.}$ of the reference sine wave from the phase angle θ of the sine wave of interest. This is written as an equation below.

$$\text{Phase shift} = \theta - \theta_{Ref.} \quad (1-10)$$

where θ is the phase angle of the sine wave of interest, expressed in degrees ($^\circ$) or radians (rad).
 $\theta_{Ref.}$ is the phase angle of the reference sine wave, expressed in degrees ($^\circ$) or radians (rad).

Figure 1-13 is an example showing how the phase shift between two sine waves (X and Y) can be calculated using their phase angles.

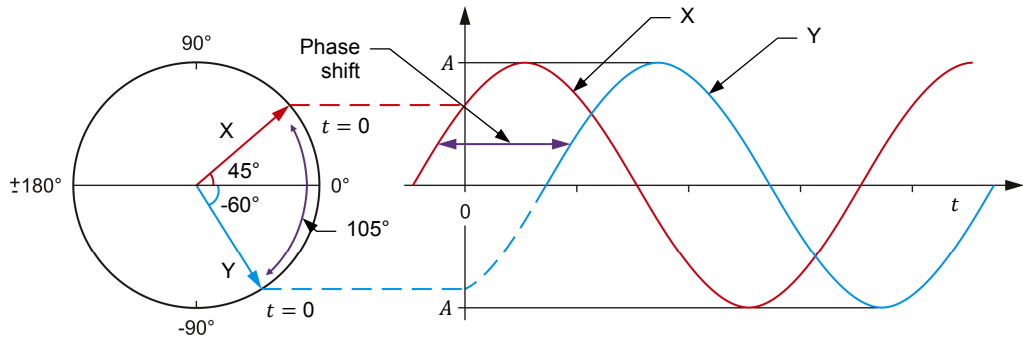

Figure 1-13. Phase shift between two sine waves with phase angles of 45° and -60°.

In the figure, sine wave X has a phase angle θ of 45°, while sine wave Y has a phase angle θ of -60°. Depending on which sine wave is used as the reference, the phase shift can be +105° or -105°. When sine wave X is considered as the reference, the phase shift of sine wave Y with respect to sine wave X is -105° ($-60^\circ - 45^\circ = -105^\circ$). The minus sign in this phase shift value indicates that sine wave Y lags reference sine wave X. For this reason, this phase shift value can also be expressed as 105° lagging. Conversely, when sine wave Y is considered as the reference, the phase shift of sine wave X with respect to sine wave Y is +105° ($45^\circ - (-60^\circ) = +105^\circ$). The plus sign in this phase shift value indicates that sine wave X leads reference sine wave Y. For this reason, this phase shift value can also be expressed as 105° leading. Note that whenever two sine waves have different phase angles, the phase shift value is not zero, and thus, these sine waves are said to be out of phase.

It is possible to determine the phase shift between two sine waves of the same frequency without knowing their respective phase angles θ . The following equation is used:

$$\text{Phase shift} = \frac{d}{T} \times 360^\circ = \frac{d}{T} \times 2\pi \text{ rad} \quad (1-11)$$

where d is the time interval between a given reference point on each of the two sine waves, expressed in seconds (s).

T is the period of the sine waves, expressed in seconds (s).

This equation shows in a concrete way why it is not possible to calculate the phase shift between two sine waves having different frequencies f , as a common period T ($T = 1/f$) is needed for the equation to be valid.

Consider, for example, the sine waves shown in Figure 1-14. Using Equation (1-11), the phase shift between the two sine waves is equal to:

$$\text{Phase shift} = \frac{d}{T} \times 360^\circ = \frac{3.33 \text{ ms}}{20.0 \text{ ms}} \times 360^\circ = 60^\circ$$

When sine wave 1 is used as the reference, the phase shift is lagging because sine wave 2 is delayed with respect to sine wave 1. Conversely, when sine wave 2 is considered as the reference, the phase shift is leading because sine wave 1 is in advance with respect to sine wave 2.

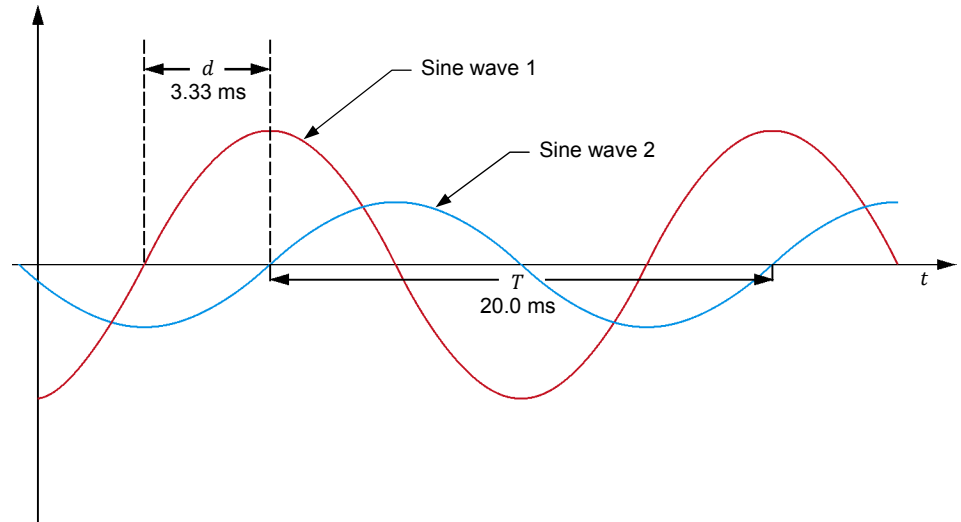

Figure 1-14. Phase shift between two sine waves having the same frequency.

PROCEDURE OUTLINE

The Procedure is divided into the following sections:

- Setup and connections
- Measuring the phase shift between two voltage sine waves in a resistor-inductor (RL) circuit
- Measuring the phase shift between two voltage sine waves in a resistor-capacitor (RC) circuit

PROCEDURE



High voltages are present in this laboratory exercise. Do not make or modify any banana jack connections with the power on unless otherwise specified.

Setup and connections

In this section, you will connect an ac circuit containing an inductor and a resistor in series and set up the equipment to measure the source voltage E_S , as well as the voltage across the resistor E_R .

1. Refer to the Equipment Utilization Chart in Appendix A to obtain the list of equipment required to perform this exercise.

Install the required equipment in the [Workstation](#).

2. Make sure that the main power switch on the **Four-Quadrant Dynamometer/Power Supply** is set to the **O** (off) position, then connect its **Power Input** to an ac power outlet.

Connect the **Power Input** of the **Data Acquisition and Control Interface** to a 24 V ac power supply. Turn the 24 V ac power supply on.

3. Connect the USB port of the **Data Acquisition and Control Interface** to a USB port of the host computer.

Connect the USB port of the **Four-Quadrant Dynamometer/Power Supply** to a USB port of the host computer.

4. Turn the **Four-Quadrant Dynamometer/Power Supply** on, then set the **Operating Mode** switch to **Power Supply**.

5. Turn the host computer on, then start the **LVDAC-EMS** software.

In the **LVDAC-EMS Start-Up** window, make sure that the **Data Acquisition and Control Interface** and the **Four-Quadrant Dynamometer/Power Supply** are detected. Make sure that the **Computer-Based Instrumentation** function for the **Data Acquisition and Control Interface** is available. Select the network voltage and frequency that correspond to the voltage and frequency of your local ac power network, then click the **OK** button to close the **LVDAC-EMS Start-Up** window.

6. Set up the circuit shown in Figure 1-15. This circuit contains a resistor R and an inductor L . Inductors are studied in the next unit of this manual.

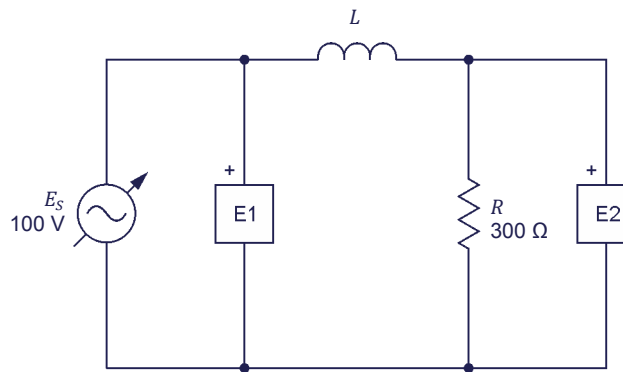

Figure 1-15. AC circuit with a resistor and an inductor.

The value of inductor L in the circuit of Figure 1-15 is referred to as the inductance and is expressed in henries (H). The inductance value to be used depends on the frequency of the ac power source as is indicated in Table 1-2.



As indicated in Appendix A, use the Inductive Load, Model 8321, to obtain the required inductance when the ac power network frequency is 60 Hz. Use the Inductive and Capacitive Loads, Model 8333, to obtain the required inductance when the ac power network frequency is 50 Hz.

Table 1-2. Inductance values for 50 and 60 Hz frequencies.

Power source frequency (Hz)	Inductance (H)
50	0.96
60	0.8

Make the necessary switch settings on the Resistive Load and Inductive Load (or on the Inductive and Capacitive Loads) in order to obtain the resistance and inductance values required.



Appendix C of this manual lists the switch settings to implement on the Resistive Load and Inductive Load in order to obtain various resistance and inductive values.

Use inputs *E1* and *E2* of the Data Acquisition and Control Interface to measure the source voltage E_S and the voltage across the resistor E_R , respectively.

7. In LVDAC-EMS, open the Four-Quadrant Dynamometer/Power Supply window, then make the following settings:
 - Set the *Function* parameter to *AC Power Source*.
 - Make sure that the *Voltage Control* parameter is set to *Knob*. This allows the ac power source to be controlled manually.
 - Set the *No Load Voltage* parameter to 100 V.
 - Set the *Frequency* parameter to the frequency of your local ac power network.
 - Leave the other parameters set as they are.

Measuring the phase shift between two voltage sine waves in a resistor-inductor (RL) circuit

In this section, you will observe the waveforms (sine waves) of the source voltage E_S and the resistor voltage E_R , using the Oscilloscope to determine the phase shift between the two sine wave voltages. Then, using the Phasor Analyzer, you will measure the phase shift between the source voltage phasor and the resistor voltage phasor and compare it to the phase shift determined from the voltage waveforms.



As you will see later, due to the presence of an inductor in the circuit, the circuit current lags behind the source voltage. As a result, the voltage E_R measured across the resistor is out of phase with respect to the source voltage E_S .

8. In LVDAC-EMS, open the **Metering** window. Set meters **E1** and **E2** to measure the rms values of the source voltage E_S and voltage across the resistor E_R , respectively.

In the **Four-Quadrant Dynamometer/Power Supply** window, enable the ac power source. Readjust the value of the **No Load Voltage** parameter so that the ac power source voltage E_S (indicated by meter **E1** in the **Metering** window) is equal to 100 V.

9. In LVDAC-EMS, open the **Oscilloscope** and display E_S (input **E1**) and E_R (input **E2**) on channels 1 and 2, respectively. If necessary, set the time base so as to display at least two cycles of the sine waves. Place the traces of the two channels at the same vertical position.
10. Measure the period T of the source voltage E_S using the **Oscilloscope** then record the value below.



To obtain an accurate measurement, you can use the vertical cursors of the Oscilloscope to measure the period or any other time interval.

Period $T =$ _____ ms

11. Measure the period T of the resistor voltage E_R using the **Oscilloscope** then record the value below.

Period $T =$ _____ ms

12. Compare the period T of the resistor voltage E_R measured in the previous step with the period T of the source voltage E_S recorded in step 10. Are the values close to each other?

Yes No

13. Measure the time interval d between the waveforms of the source voltage E_S and resistor voltage E_R by using the **Oscilloscope**.

Time interval $d =$ _____ ms

14. Using Equation (1-11), calculate the phase shift between the source voltage E_S and the resistor voltage E_R . Consider the source voltage waveform as the reference.

Phase shift = _____ °

15. Is the resistor voltage E_R leading or lagging the source voltage E_S ?
-

16. In LVDAC-EMS, open the Phasor Analyzer and display the source voltage E_S (input E1) and resistor voltage E_R (input E2). Set the Reference Phasor parameter to E1. Measure the phase angles θ_{ES} and θ_{ER} of the voltage phasors.

Phase angle $\theta_{ES} = \underline{\hspace{2cm}}^\circ$

Phase angle $\theta_{ER} = \underline{\hspace{2cm}}^\circ$

From these values, calculate the phase shift between the phasors of the source voltage E_S and resistor voltage E_R , using the source voltage phasor as the reference.

Phase shift = $\underline{\hspace{2cm}}^\circ$

17. Compare the phase shift you determined from the voltage sine waves to the phase shift you measured from the corresponding voltage phasors. Are both values close to each other?

Yes No

Measuring the phase shift between two voltage sine waves in a resistor-capacitor (RC) circuit

In this section, you will replace the inductor used in the previous section by a capacitor. Using the Oscilloscope, you will determine the phase shift between the two voltage sine waves. Then, using the Phasor Analyzer, you will measure the phase shift between the source voltage phasor and the resistor voltage phasor and compare it to the phase shift you determined from the voltage waveforms.



As you will see later, due to the presence of a capacitor in the circuit, the circuit current leads the source voltage. As a result, the resistor voltage E_R is out of phase with respect to the source voltage E_S .

18. In the Four-Quadrant Dynamometer/Power Supply window, disable the ac power source.
19. Modify the circuit so that it is as shown in Figure 1-16 (replace the inductor by a capacitor). This circuit contains a resistor R and a capacitor C . Capacitors are studied in the next unit of this manual.

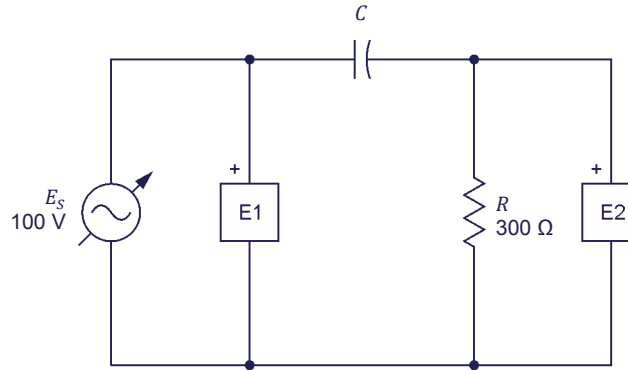

Figure 1-16. AC circuit with a resistor and a capacitor.

The value of capacitor C in the circuit of Figure 1-16 is referred to as the capacitance and is expressed in microfarads (μF). The capacitance value to be used depends on the frequency of the ac power source as is indicated in Table 1-3.



As indicated in Appendix A, use the *Capacitive Load, Model 8331*, to obtain the required capacitance when the ac power network frequency is 60 Hz. Use the *Inductive and Capacitive Loads, Model 8333*, to obtain the required capacitance when the ac power network frequency is 50Hz.

Table 1-3. Capacitance values for 50 and 60 Hz frequencies.

Power source frequency (Hz)	Capacitance (μF)
50	5.3
60	4.4

Make the necessary switch settings on the *Resistive Load* and *Capacitive Load* (or on the *Inductive and Capacitive Loads*) in order to obtain the resistance and capacitance values required.

20. In the *Four-Quadrant Dynamometer/Power Supply* window, enable the ac power source. In the *Four-Quadrant Dynamometer/Power Supply* window, readjust the value of the *No Load Voltage* parameter, if necessary, so that the ac power source voltage E_s (indicated by meter *E1* in the *Metering* window) is equal to 100 V.

21. Measure the period T of the source voltage using the *Oscilloscope* then record the value below.

Period $T =$ _____ ms

22. Measure the period T of the resistor voltage E_R using the **Oscilloscope** then record the value below.

Period $T =$ _____ ms

23. Compare the period T of the resistor voltage E_R measured in the previous step with the period T of the source voltage E_S recorded in step 21. Are the values close to each other?

Yes No

24. Measure the time interval d between the waveforms of the source voltage E_S and resistor voltage E_R .

Time interval $d =$ _____ ms

25. Using Equation (1-11), calculate the phase shift between the source voltage E_S and the resistor voltage E_R . Consider the source voltage waveform as the reference.

Phase shift = _____ °

26. Is the resistor voltage E_R leading or lagging the source voltage E_S ?

27. In the **Phasor Analyzer**, measure the phase angles θ_{ES} and θ_{ER} of the voltage phasors.

Phase angle $\theta_{ES} =$ _____ °

Phase angle $\theta_{ER} =$ _____ °

From these values, calculate the phase shift between the phasors of the source voltage E_S and resistor voltage E_R , using the source voltage phasor as the reference.

Phase shift = _____ °

28. Compare the phase shift you determined from the voltage sine waves to the phase shift you measured from the corresponding voltage phasors. Are both values close to each other?

Yes No

29. In the **Four-Quadrant Dynamometer/Power Supply** window, disable the ac power source.

30. Close LVDAC-EMS, then turn off all the equipment. Disconnect all leads and return them to their storage location.

CONCLUSION

In this exercise, you saw how the phase angle modifies the value of a sine wave at time $t = 0$, and thus, the position in time of the sine wave. You observed the effects of positive and negative phase angles on the relative position in time of a sine wave. You were introduced to the notion of phase shift. You learned how to calculate and measure the phase shift between two sine waves and to differentiate between a lagging and a leading phase shift.

REVIEW QUESTIONS

1. What is the effect of the phase angle on the graphical representation of a sine wave?

2. A sine wave has a phase angle θ of 72° . Will this sine wave reach its maximum value before, after or at the same time as a second waveform having a phase angle θ of -18° ?

3. Given the following two sine wave equations:

$$E(t) = 8 \sin 20t + 78^\circ$$

$$E(t) = 40 \sin 20t + 43^\circ$$

Calculate the phase shift between these two sine waves, considering the first sine wave as the reference. Indicate also whether the second sine wave is lagging or leading the reference sine wave.

4. When calculating the phase shift between two sine waves, which of the following parameters do the two sine waves need to have in common: phase angle, amplitude, frequency, or period? Why?

5. Consider two sine waves with the same frequency. They both have a period T of 50 ms. The second sine wave reaches its maximum positive value 8 ms after the first. Calculate the phase shift between the two sine waves, considering the first one as the reference.

Instantaneous Power and Average Power

EXERCISE OBJECTIVE

When you have completed this exercise, you will know the difference between instantaneous power and average power, and how to calculate them. You will be able to explain and demonstrate the concept of instantaneous power in ac circuits. You will also be able to determine the average power dissipated in a resistor when it is connected to an ac power source. You will be able to demonstrate the relationship between rms values and average power in resistive ac circuits.

DISCUSSION OUTLINE

The Discussion of this exercise covers the following points:

- Instantaneous power
- Average power
- Rationale behind rms values

DISCUSSION

Instantaneous power

When electrical power is supplied to a dc motor, a fraction of the power is converted into mechanical energy and the remainder is converted into heat. When power is supplied to a storage battery during charge, some of the power is converted in chemical energy, while the rest is converted in heat. However, when power is supplied to a resistor, all power is converted into heat. This conversion of electrical power into heat is a very efficient process, and we make use of it every day in electric toasters, stoves, and electrically-heated homes.

In dc circuits, power P is the product of the voltage E and the current I . The same is true for ac circuits. However, in the case of ac circuits, it is important to know the difference between **instantaneous power** and **average power**. From what has been seen so far, it should be clear that the power supplied to a load connected to an ac source varies with time, since the circuit voltage and current are sine waves. Instantaneous power P is equal to the $E \times I$ product calculated at each instant of the sine wave cycle. Figure 1-17 shows an example of a power waveform in relation to the voltage and current sine waves. As you can see, in the first half of their cycle, both the voltage and current sine waves have positive values, while in the second half, they both have negative values. Thus, the $E \times I$ product (i.e., the power waveform) is always positive, whether or not the voltage and current sine waves are in the positive or negative half of the cycle. As a result, the net power delivered to the load is equal to the power delivered during the positive half-wave plus the power delivered during the negative half-wave.

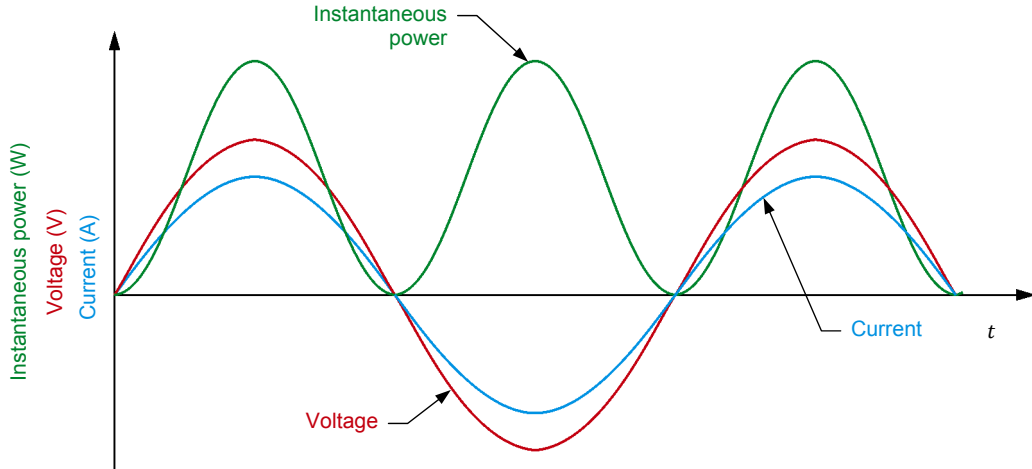

Figure 1-17. Voltage, current, and instantaneous power waveforms for a resistor.

A wattmeter connected to measure the power delivered to the load in a simple resistive ac circuit would thus indicate a concrete power value other than zero, even though the average value over a period of the voltage and current waveforms is zero.

As you can see from the power waveform in Figure 1-17, the frequency of the instantaneous power waveform is twice that of the source. This is due to the fact that when the voltage and current waveforms begin the negative half of their cycles, the power waveform begins another cycle that is identical to the previous one.

Average power

While the instantaneous power varies with time, the average power $P_{Avg.}$ dissipated in the resistor (or average value of the power waveform) remains constant through time and corresponds to the product of the rms voltage E_{RMS} and the rms current I_{RMS} , as shown in the equation below:

$$P_{Avg.} = E_{RMS} \times I_{RMS} \tag{1-12}$$

where $P_{Avg.}$ is the average power, expressed in watts (W).

E_{RMS} is the rms voltage, expressed in volts (V).

I_{RMS} is the rms current, expressed in amperes (A).

Figure 1-18 shows the comparison between the instantaneous power waveform and the average power graphical representation. Note that this relationship is only valid for purely resistive ac circuits.

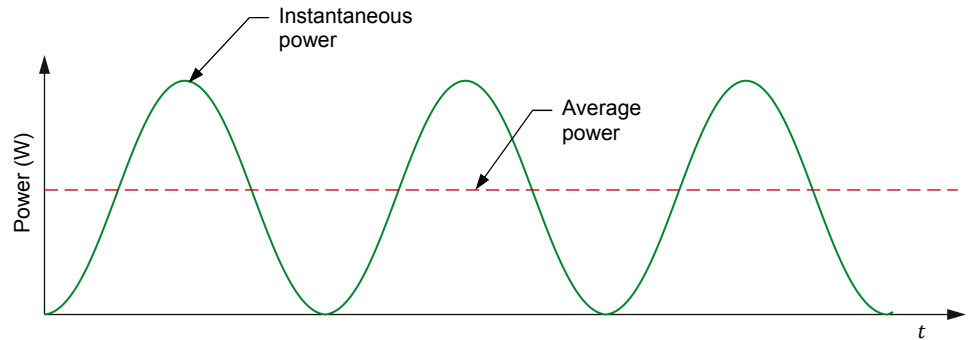

Figure 1-18. Instantaneous power and average power.

Rationale behind rms values

In Exercise 1-1, the concept of rms values was first introduced without a full explanation of the rationale behind it. Using the concept of average power, we can now better understand the relationship between the rms voltage measured in an ac circuit and the voltage measured in a dc circuit.

Consider the ac circuit shown in Figure 1-19a. In this circuit, the ac power source delivers a given amount of average power $P_{Avg.}$ to a resistor. Now, to deliver that same amount of power P_{DC} to the same resistor in the dc circuit shown in Figure 1-19b, the dc power source needs to be set to a particular voltage E_{DC} . This voltage E_{DC} is equal to the rms voltage E_{RMS} of the ac power source. In other words, when the power delivered to a resistive load by an ac power source is equal to the power delivered to an equivalent resistive load by a dc power source ($P_{Avg.} = P_{DC}$), the rms voltage of the ac power source is equal to the voltage of the dc power source ($E_{RMS} = E_{DC}$). Note that, for reasons that will be seen later, this relationship is only true in the case of resistive loads and is not valid when other components (e.g., inductors and capacitors) are introduced in a circuit.

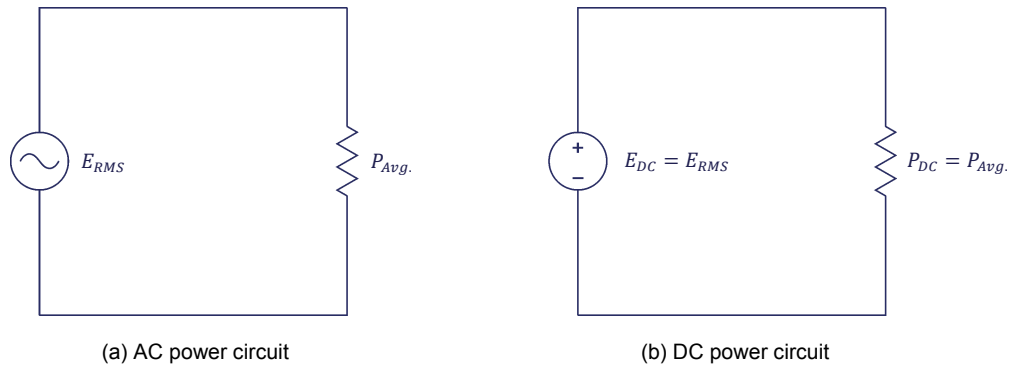

Figure 1-19. Equivalent ac and dc circuits supplying the same voltage and delivering the same power.

The above rationale also applies to the rms values of current in an ac circuit. Thus, when the current I_{DC} of a dc power source is equal to the rms value of the current I_{RMS} in an ac circuit, then the power P_{DC} dissipated in the resistor in the dc circuit is equal to the average power $P_{Avg.}$ dissipated in the same resistor in the ac circuit.

PROCEDURE OUTLINE

The Procedure is divided into the following sections:

- Setup and connections
- Average power measurements
- Rationale behind rms values

PROCEDURE



High voltages are present in this laboratory exercise. Do not make or modify any banana jack connections with the power on unless otherwise specified.

Setup and connections

In this section, you will connect an ac circuit containing a resistor and set up the equipment to measure the source voltage E_S , source current I_S , and power P_S delivered to the resistor by the source.

1. Refer to the Equipment Utilization Chart in Appendix A to obtain the list of equipment required to perform this exercise.

Install the required equipment in the [Workstation](#).

2. Make sure that the main power switch on the [Four-Quadrant Dynamometer/Power Supply](#) is set to the **O** (off) position, then connect its [Power Input](#) to an ac power outlet.

Connect the [Power Input](#) of the [Data Acquisition and Control Interface](#) to a 24 V ac power supply. Turn the 24 V ac power supply on.

3. Connect the USB port of the [Data Acquisition and Control Interface](#) to a USB port of the host computer.

Connect the USB port of the [Four-Quadrant Dynamometer/Power Supply](#) to a USB port of the host computer.

4. Turn the [Four-Quadrant Dynamometer/Power Supply](#) on, then set the [Operating Mode](#) switch to [Power Supply](#).

5. Turn the host computer on, then start the [LVDAC-EMS](#) software.

In the [LVDAC-EMS Start-Up](#) window, make sure that the [Data Acquisition and Control Interface](#) and the [Four-Quadrant Dynamometer/Power Supply](#) are detected. Make sure that the [Computer-Based Instrumentation](#) function for the [Data Acquisition and Control Interface](#) is available. Select the network voltage and frequency that correspond to the voltage and frequency of your local ac power network, then click the **OK** button to close the [LVDAC-EMS Start-Up](#) window.

6. Set up the circuit shown in Figure 1-20.

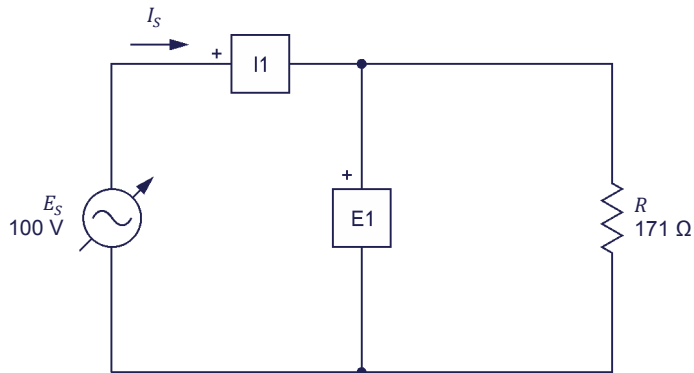

Figure 1-20. AC circuit containing a resistor, as well as a voltmeter and an ammeter for voltage, current, and power measurements.

Make the necessary switch settings on the [Resistive Load](#) in order to obtain the resistance value required.

Use inputs *E1* and *I1* of the [Data Acquisition and Control Interface](#) to measure the source voltage E_S and the source current I_S , respectively.

7. In [LVDAC-EMS](#), open the [Four-Quadrant Dynamometer/Power Supply](#) window, then make the following settings:
- Set the *Function* parameter to [AC Power Source](#).
 - Make sure that the *Voltage Control* parameter is set to [Knob](#). This allows the ac power source to be controlled manually.
 - Set the *No Load Voltage* parameter to 100 V.
 - Set the *Frequency* parameter to the frequency of your local ac power network.
 - Leave the other parameters set as they are.

Average power measurements

In this section, you will observe the waveforms of the source voltage E_S , source current I_S , and power P_S which the ac power source delivers to the resistor in the ac power circuit you set-up in the previous section. You will measure the average source power $P_{S,avg.}$, as well as the rms values of the source voltage E_S and source current I_S . You will then calculate the source power P_S from the measured rms values of the source voltage E_S and current I_S and compare the result with the measured source power P_S .

8. In **LVDAC-EMS**, open the **Metering** window. Set meters **E1** and **I1** to measure the rms values of the ac power source voltage E_S and source current I_S , respectively.

In the **Four-Quadrant Dynamometer/Power Supply** window, enable the ac power source. Readjust the value of the **No Load Voltage** parameter so that the ac power source voltage E_S (indicated by meter **E1** in the **Metering** window) is equal to 100 V.

9. In **LVDAC-EMS**, open the **Oscilloscope** and set the parameters to display the source voltage E_S , source current I_S , and power P_S which the ac power source delivers to the resistor on channels 1, 2, and 3, respectively. Ensure that the time base is adjusted to show at least two complete cycles of the waveforms and select convenient vertical scales.
10. On the **Oscilloscope**, determine the period T of the waveforms of the source voltage E_S and source current I_S , then calculate the source frequency f from the measured period T .

Period $T =$ _____ ms Frequency $f = \frac{1}{T} =$ _____ Hz

11. On the **Oscilloscope**, determine the period T of the waveform of instantaneous power P_S , then calculate the source frequency f from the measured period T .

Period $T =$ _____ ms Frequency $f = \frac{1}{T} =$ _____ Hz

12. How does the frequency f of the waveform of instantaneous power P_S obtained in the previous step compare with the frequency of the current I_S and voltage E_S recorded in step 10?

13. Observe that the polarity of the waveform of instantaneous power P_S is always positive. Explain why.

14. On the **Oscilloscope**, record the average value $P_{S,avg.}$ of the waveform of the source power P_S .

Average power $P_{S,avg.} = \underline{\hspace{2cm}}$ W

15. Record below the rms values of the source voltage E_S and source current I_S , indicated by meters **E1** and **I1** in the **Metering** window, respectively.

Source voltage $E_S = \underline{\hspace{2cm}}$ V Source current $I_S = \underline{\hspace{2cm}}$ A

16. Calculate the power P_S which the source delivers to the load resistor using the rms values of E_S and I_S measured in the previous step.

Power $P_S = I_S \times E_S = \underline{\hspace{2cm}}$ W

17. Compare the power P_S calculated in the previous step with the average power $P_{S,avg.}$ recorded in step 14. Are the values close to each other?

Yes No

18. Does this confirm that the average power dissipated in a resistor connected to an ac power source is equal to the product of the rms values of the resistor voltage and current?

Yes No

Rationale behind rms values

In this section, you will set the Four-Quadrant Dynamometer/Power Supply so that it operates as a dc power source. You will then adjust the dc source voltage until you obtain a power P_{DC} that is equal to the average power $P_{S,avg}$ obtained previously using the ac power source. This will allow you to determine the relationship between the dc voltage value and the rms voltage value when the same amount of power is delivered to a resistive load.

19. In the **Four-Quadrant Dynamometer/Power Supply** window, set the **Function** parameter to **DC Voltage Source**. This changes the ac power source to a dc power source and automatically sets the status of the **Four-Quadrant Dynamometer/Power Supply** to **Stopped**.

The circuit is now set-up as shown in Figure 1-21.

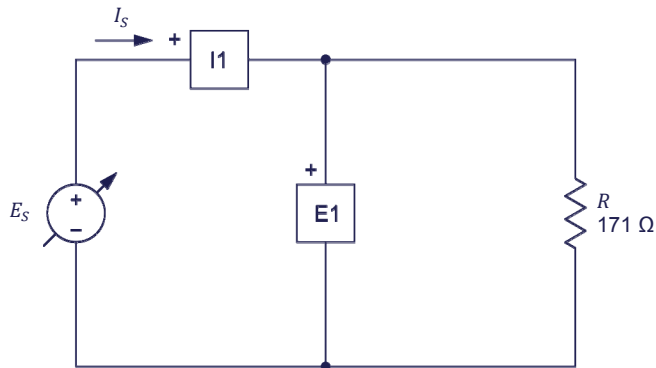

Figure 1-21. DC circuit containing a resistor, as well as a voltmeter and an ammeter for voltage, current, and power measurements.

20. In the **Four-Quadrant Dynamometer/Power Supply** window, enable the dc power source, then adjust the voltage of the dc power source so that the power P_{DC} delivered to the resistor (see the average value of the power waveform in channel 3 indicated under the **Oscilloscope** display) is equal to the average power $P_{S,avg}$ delivered by the ac power source in the previous section (recorded in step 14). Record the dc source voltage E_{DC} below:

DC source voltage $E_{DC} = \underline{\hspace{2cm}}$ V

21. Compare the measured dc source voltage E_{DC} to the rms voltage E_S of the ac power source used in the previous section (recorded in step 15). Are the values close to each other?

Yes No

22. What can you conclude about the rms value of the voltage (or current) in ac circuits containing a resistive load?

23. In the [Four-Quadrant Dynamometer/Power Supply](#) window, disable the dc power source.

24. Close [LVDAC-EMS](#), then turn off all the equipment. Disconnect all leads and return them to their storage location.

CONCLUSION

In this exercise, you were introduced to the notion of instantaneous power and average power and saw how to differentiate between them. You saw how to calculate the instantaneous power in an ac circuit as well as how to represent instantaneous power graphically. You learned how to determine the average power dissipated in an ac circuit. You also learned the relationship between rms voltage values and dc voltage values in circuits containing resistive loads.

REVIEW QUESTIONS

1. What is the difference between the average power and the instantaneous power in an ac circuit?

2. How is it possible to calculate the average power dissipated in an ac circuit?

3. What is the frequency of a power waveform compared to the corresponding voltage and current sine waves? Explain why.

4. What is the average power $P_{s,avg}$ dissipated by a $100\ \Omega$ resistor when it is connected to an ac source having an amplitude of $141\ \text{V}$?

5. A sinusoidal voltage having a period T of $20.0\ \text{ms}$ is applied to a resistive load. What is the frequency of the power waveform at the resistor?

Unit Test

1. What is the period of a sine wave?
 - a. The time between the positive and negative half-waves of the sine wave.
 - b. The number of times its cycle repeats itself in a second.
 - c. The time between the maximum positive value and the maximum negative value.
 - d. The time it takes for the sine wave to complete one cycle.
2. What is the period of a sine wave whose frequency is 120 Hz?
 - a. 120 ms
 - b. 8.3 ms
 - c. 33.4 ms
 - d. 16.7 ms
3. AC power produces a current which changes direction periodically and alternates between maximum positive and negative values.
 - a. True
 - b. False
 - c. It depends on the frequency f .
 - d. None of the above.
4. What is the phase shift between the voltage and current in a circuit containing only a resistive load?
 - a. 180°
 - b. 90°
 - c. There is no phase shift.
 - d. It depends on the power dissipated in the load.
5. Given the following ac voltage equations: $E(t) = 15 \sin(30t + 25)$ and $E(t) = 5 \sin(30t - 55)$, calculate the phase shift between them. Consider the second one as the reference.
 - a. -30°
 - b. 80°
 - c. -80°
 - d. It is impossible to calculate their phase shift as they do not have the same frequency.
6. The phase angle of a sine wave determines the:
 - a. frequency of the sine wave.
 - b. initial value of the sine wave.
 - c. maximum positive and negative values of the sine wave.
 - d. duration of the positive and negative half-waves of the sine wave.

7. In a given circuit containing only a resistor, an ac power source will dissipate more power than a dc power source having a voltage equal to the amplitude of the ac voltage sine wave.
 - a. True
 - b. False, because the ac power source average power value is zero over a complete period.
 - c. False, because the amplitude of an ac voltage sine wave is greater than its rms voltage value.
 - d. True, because power equals the product of the rms voltage and current values.

8. The instantaneous power waveform in a dc circuit is the same as in an ac circuit.
 - a. True
 - b. False, the instantaneous power in a dc circuit is constant.
 - c. True, if they have the same frequency.
 - d. False, instantaneous power does not exist in dc circuits.

9. The maximum positive and negative values of a sine wave are determined by the:
 - a. phase angle.
 - b. period.
 - c. frequency.
 - d. amplitude.

10. What is the amplitude of a voltage sine wave if it produces the same average power in a resistor as a dc voltage of 50 V?
 - a. 70.5 V
 - b. 141 V
 - c. 50 V
 - d. 35.5 V

Resistance, Reactance, and Impedance

UNIT OBJECTIVE

When you have completed this unit, you will know what an inductor and a capacitor are. You will be able to calculate the inductive reactance of an inductor from its inductance and the capacitive reactance of a capacitor from its capacitance. You will be familiar with the relationship between the source frequency and the reactance of an inductor or a capacitor. You will also know the effects of introducing an inductor and a capacitor in an ac circuit on the voltage and current waveforms.

DISCUSSION OUTLINE

The Discussion of Fundamentals covers the following points:

- Introduction to inductors and capacitors
- Distinction between resistance, reactance, and impedance

DISCUSSION OF FUNDAMENTALS

Introduction to inductors and capacitors

Most circuits studied so far contained only resistive components. Typical ac circuits, however, contain two other fundamental types of components: **inductors** and **capacitors**. In Exercise 1-2, you used an inductor and a capacitor to produce a phase shift between the voltage and current sine waves in an ac circuit. This unit covers inductors and capacitors in more detail.

Inductors are widely used in ac circuits. In fact, the windings of transformers and ac motors are fundamentally inductors, which means that the windings have the same effect as an inductor when introduced in an ac circuit. Inductors can also be deliberately added to ac circuits in order to modify the circuit characteristics. Figure 2-1 shows some of the many types of inductors available. An inductor consists essentially of a conducting wire shaped as a coil. Current flowing through the wire creates a strong magnetic field inside the coil.



Figure 2-1. Various types of inductors.

Capacitors, like inductors, are added to ac circuits in order to modify the circuit's basic characteristics. For instance, a capacitor can be connected to the windings of certain single-phase induction motors in order to allow the motors to start without external assistance when power is turned on. Capacitors generally have the opposite effect of inductors in ac circuits. Figure 2-2 shows some capacitors of different sizes and shapes.



Figure 2-2. Various types of capacitors.

Distinction between resistance, reactance, and impedance

Like resistors, inductors and capacitors oppose current flow in electrical circuits. However, while the opposition to current flow produced by resistors is called resistance, the opposition to current flow caused by inductors and capacitors is referred to as **reactance**. Like resistance, reactance is expressed in ohms (Ω). The reactance of an inductor is known as **inductive reactance** while the

reactance of a capacitor is known as **capacitive reactance**. Reactance is studied in detail in the first two exercises of this unit.

The total opposition to current flow in an ac circuit, i.e., the opposition to current flow due to all resistors, inductors, and capacitors in the circuit, is referred to as the **impedance**. Impedance, like resistance and reactance, is expressed in ohms (Ω). Impedance is studied in the third exercise of this unit.

Inductive Reactance

EXERCISE OBJECTIVE

When you have completed this exercise, you will know what an inductor is. You will be able to calculate the inductive reactance of an inductor from its inductance. You will know the relationship between the source frequency and the inductive reactance of an inductor. You will also know the effect of introducing an inductor in an ac circuit on the voltage and current waveforms.

DISCUSSION OUTLINE

The Discussion of this exercise covers the following points:

- Inductors and inductive reactance
- Inductive phase shift

DISCUSSION

Inductors and inductive reactance

An inductor consists basically of a coil of wire with or without an iron core. Inductors store energy in the magnetic field that is produced when current flows through the coil. As a result, inductors oppose current changes.

The fundamental characteristic of an inductor is the **inductance** L , which is expressed in henries (H). Inductance is one of the main factors that determine the opposition to current flow of an inductor, i.e., the inductive reactance X_L . As for resistance, inductive reactance is expressed in ohms (Ω). The equation for inductive reactance is given below:

$$X_L = 2\pi fL \quad (2-1)$$

where X_L is the inductive reactance of the inductor, expressed in ohms (Ω).

f is the frequency of the ac power source, expressed in hertz (Hz).

L is the inductance of the inductor, expressed in henries (H).

Equation (2-1) shows that the inductive reactance X_L of an inductor is directly proportional to the inductance L of the inductor and the frequency f of the ac power source.

The current flowing in a resistor is equal to E/R . Notice the similarity with the equation for the current flowing in an inductor.

Ohm's law states that the current I flowing in an inductor is equal to E/X_L . Therefore, the higher the inductive reactance of the inductor, the lower the inductor current.

Inductive phase shift

Another fundamental characteristic of an inductor is that the sine wave of the current flowing in the inductor lags the sine wave of the voltage across the inductor by 90° . Figure 2-3 shows the typical voltage and current waveforms related to an inductor and the corresponding phasors.

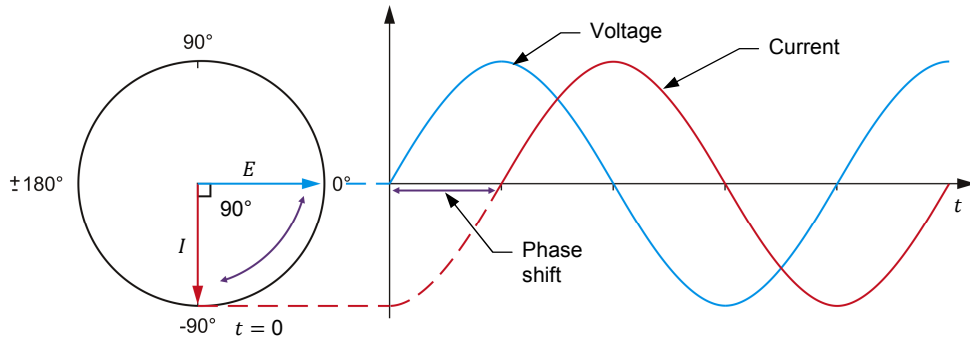

Figure 2-3. Voltage and current waveforms related to an inductor and corresponding phasors.

The 90° phase shift between the voltage and current sine waves related to an inductor is only true for ideal inductors. For actual inductors, the current lags the voltage by a little less than 90° . This is because the wire of the inductor coil itself has a certain resistance. This resistance adds to the opposition to current flow produced by the inductor, i.e., the total opposition to current flow created by the inductor is equal to the inductive reactance plus the resistance of the wire coil. The exact relationship between inductance and resistance is explained in Exercise 2-3 of this manual.

PROCEDURE OUTLINE

The Procedure is divided into the following sections:

- Setup and connections
- Inductance and inductive reactance
- Effect of frequency on the inductive reactance
- Measuring the inductive phase shift

PROCEDURE



High voltages are present in this laboratory exercise. Do not make or modify any banana jack connections with the power on unless otherwise specified.

Setup and connections

In this section, you will connect an ac circuit containing an inductor and set up the equipment to measure the voltage E_L across the inductor and the current I_L flowing through the inductor.

1. Refer to the Equipment Utilization Chart in Appendix A to obtain the list of equipment required to perform this exercise.

Install the required equipment in the [Workstation](#).

2. Make sure that the main power switch on the [Four-Quadrant Dynamometer/Power Supply](#) is set to the O (off) position, then connect its *Power Input* to an ac power outlet.

Connect the *Power Input* of the [Data Acquisition and Control Interface](#) to a 24 V ac power supply. Turn the 24 V ac power supply on.

3. Connect the USB port of the [Data Acquisition and Control Interface](#) to a USB port of the host computer.

Connect the USB port of the [Four-Quadrant Dynamometer/Power Supply](#) to a USB port of the host computer.

4. Turn the [Four-Quadrant Dynamometer/Power Supply](#) on, then set the *Operating Mode* switch to *Power Supply*.

5. Turn the host computer on, then start the [LVDAC-EMS](#) software.

In the [LVDAC-EMS Start-Up](#) window, make sure that the [Data Acquisition and Control Interface](#) and the [Four-Quadrant Dynamometer/Power Supply](#) are detected. Make sure that the *Computer-Based Instrumentation* function for the [Data Acquisition and Control Interface](#) is available. Select the network voltage and frequency that correspond to the voltage and frequency of your local ac power network, then click the **OK** button to close the [LVDAC-EMS Start-Up](#) window.

6. Set up the circuit shown in Figure 2-4.

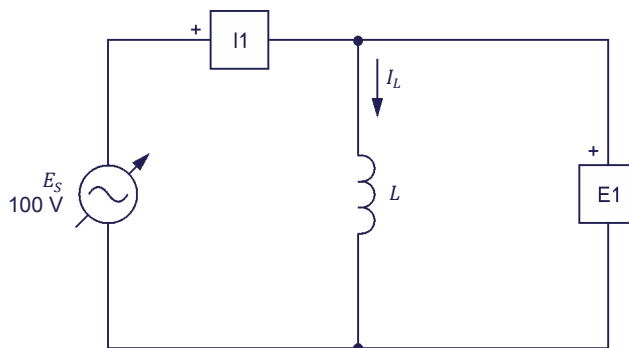

Figure 2-4. AC circuit containing an inductor.

The value of the inductance L to be used in the circuit of Figure 2-4 depends on the frequency of the ac power source, as indicated in Table 2-1.

Table 2-1. First and second inductance values for frequencies of 50 Hz and 60 Hz.

Power source frequency (Hz)	Inductance L (H)	
	First value	Second value
50	0.96	1.92
60	0.80	1.60

Use inputs $E1$ and $I1$ of the Data Acquisition and Control Interface to measure the inductor voltage E_L and current I_L , respectively.

7. In LVDAC-EMS, open the Four-Quadrant Dynamometer/Power Supply window, then make the following settings:
 - Set the *Function* parameter to *AC Power Source*.
 - Make sure that the *Voltage Control* parameter is set to *Knob*. This allows the ac power source to be controlled manually.
 - Set the *No Load Voltage* parameter to 100 V.
 - Set the *Frequency* parameter to the frequency of your local ac power network.
 - Leave the other parameters set as they are.

Make the necessary switch settings on the Inductive Load (or on the Inductive and Capacitive Loads) in order to obtain the first inductance value required (refer to Table 2-1).

Inductance and inductive reactance

In this section, you will calculate the inductive reactance X_L of the inductor for the first value of inductance L in Table 2-1. You will measure the inductor voltage E_L and current I_L . You will then determine the inductive reactance X_L of the inductor from the measured inductor voltage E_L and current I_L and compare the result to the calculated inductive reactance X_L . You will double the value of inductance L to determine the effect on the inductive reactance X_L of the inductor.

8. Calculate the inductive reactance X_L of the inductor for the first value of inductance L in Table 2-1 and record the result below.

Calculated inductive reactance $X_L = \underline{\hspace{2cm}} \Omega$

9. In the Four-Quadrant Dynamometer/Power Supply window, enable the ac power source.

10. In LVDAC-EMS, open the **Metering** window. Set meters **E1** and **I1** to measure the rms values of the inductor voltage E_L and current I_L , respectively.

In the **Four-Quadrant Dynamometer/Power Supply** window, readjust the value of the **No Load Voltage** parameter so that the ac power source voltage (indicated by meter **E1** in the **Metering** window) is equal to 100 V.

Record below the measured values of the inductor voltage E_L and current I_L (meters **E1** and **I1**, respectively).

Inductor voltage $E_L = \underline{\hspace{2cm}}$ V Inductor current $I_L = \underline{\hspace{2cm}}$ A

11. Calculate the inductive reactance X_L of the inductor using the inductor voltage E_L and current I_L measured in the previous step.

Inductive reactance $X_L = \underline{\hspace{2cm}}$ Ω

12. Compare the inductive reactance X_L obtained in the previous step with the calculated inductive reactance X_L recorded in step 8. Are the values close to each other?

Yes No

13. Set the inductance L of the inductor to the second value indicated in Table 2-1 by making the necessary switch settings on the **Inductive Load**.

14. Calculate the inductive reactance X_L of the inductor for the second value of inductance L in Table 2-1 and record the result in the second column in Table 2-2 (see next procedure section).

Indicate the frequency (50 or 60 Hz) of your local ac power network in the first column in Table 2-2.

15. In the **Metering** window, measure the rms values of the inductor voltage E_L and current I_L . Record the values in the proper cells of the third and fourth columns in Table 2-2.

16. Calculate the inductive reactance X_L of the inductor using the inductor voltage E_L and current I_L measured in the previous step. Record the result in the fifth column in Table 2-2.

17. Compare the inductive reactance X_L obtained in the previous step with the calculated inductive reactance X_L recorded in step 14. Are the values close to each other?

Yes No

18. Compare the inductive reactance X_L of the inductor for the first inductance value to the inductive reactance X_L for the second inductance value. What happened to the inductive reactance X_L of the inductor when you doubled the inductance L ? Describe the relationship between the inductance L and the inductive reactance X_L of an inductor.

Effect of frequency on the inductive reactance

In this section, you will calculate the inductive reactance X_L of the inductor using the second value of inductance L in Table 2-1, for ac power source frequencies of 40 Hz and 70 Hz. For each of these two frequencies, you will measure the inductor voltage E_L and current I_L , calculate the inductive reactance X_L of the inductor from the measured voltage and current, and compare it with the corresponding calculated inductive reactance X_L . Using the inductive reactance values calculated from the measured inductor voltages and currents, you will determine the relationship between the source frequency f and the inductive reactance X_L .

19. Calculate the inductive reactance X_L of the inductor (using the second value of inductance L indicated in Table 2-1) at frequencies of 40 and 70 Hz. Record the results in the proper cells of the second column in Table 2-2.

Table 2-2. Calculated inductive reactance and measured voltage E_L , current I_L , and inductive reactance for various frequencies.

Power source frequency (Hz)	Calculated inductive reactance X_L (Ω)	Inductor voltage E_L (V)	Inductor current I_L (A)	Inductive reactance X_L (Ω)
40				
50 or 60				
70				

20. In the **Four-Quadrant Dynamometer/Power Supply** window, set the **Frequency** parameter to 40 Hz.
21. In the **Metering** window, measure the rms values of the inductor voltage E_L and current I_L and record the values in the proper cells of the third and fourth columns in Table 2-2.
22. Calculate the inductive reactance X_L of the inductor from the inductor voltage E_L and current I_L measured in the previous step. Record the result in the proper cell of the fifth column in Table 2-2.

23. In the [Four-Quadrant Dynamometer/Power Supply](#) window, set the [Frequency](#) parameter to 70 Hz, then repeat steps 21 and 22.
24. Determine the relationship between the inductive reactance X_L of an inductor and the ac power source frequency using the values recorded in Table 2-2.
-
-

Measuring the inductive phase shift

In this section, you will observe the waveforms of the inductor voltage and current using the Oscilloscope to determine the phase shift between these parameters. Then, using the Phasor Analyzer, you will measure the phase shift between the inductor voltage phasor and the inductor current phasor, and compare the result to the phase shift you determined from the voltage and current waveforms.

25. In the [Four-Quadrant Dynamometer/Power Supply](#) window, set the [Frequency](#) parameter to the frequency of your local ac power network.
26. In [LVDAC-EMS](#), open the [Oscilloscope](#) and display the inductor voltage and current on channels 1 and 2, respectively. If necessary, set the time base to display at least two cycles of the waveforms. Select channel 1 (inductor voltage) as the trigger source then set the trigger level to 0 V.

Notice that the amplitude of the inductor voltage waveform is equivalent to the rms value of the inductor voltage E_L indicated in the [Metering](#) window. Also notice that the amplitude of the inductor current waveform is equivalent to the rms value of the inductor current I_L indicated in the [Metering](#) window.

27. Does the sine wave of the inductor current lag the sine wave of the inductor voltage?

Yes No

28. Using the [Oscilloscope](#), determine the period T of the waveforms of the inductor voltage and the inductor current. Record the value below.

Period T = _____ ms

29. Using the **Oscilloscope**, determine the time interval d between the inductor voltage and the inductor current, then calculate the phase shift between the two waveforms.

Consider the inductor voltage waveform as the reference.

Time interval $d =$ _____ ms

Phase shift $= \frac{d}{T} \times 360 =$ _____ °

30. In **LVDAC-EMS**, open the **Phasor Analyzer** and display the inductor voltage E_L (input **E1**) and current I_L (input **I1**). Set the **Reference Phasor** parameter to the inductor voltage E_L (input **E1**). Record the phase shift between the inductor voltage phasor and inductor current phasor below. Knowing that phasors rotate counterclockwise, indicate whether the phasor of the inductor current I_L leads or lags the phasor of the inductor voltage E_L .



*Notice how the length of the inductor voltage phasor and inductor current phasor corresponds to the voltage and current values indicated in the **Metering** window.*

Phase shift = _____ °

31. Compare the phase shift you determined from the inductor voltage and current waveforms with the phase shift measured from the corresponding phasors of the inductor voltage and current. Are both values close to each other?

Yes No

32. In the **Four-Quadrant Dynamometer/Power Supply** window, disable the ac power source.
33. Close **LVDAC-EMS**, then turn off all the equipment. Disconnect all leads and return them to their storage location.

CONCLUSION

In this exercise, you learned what an inductor is. You also learned how to calculate the inductive reactance of an inductor from its inductance. You saw the relationship between the source frequency and the inductive reactance of an inductor. You verified the phase shift between the voltage and current related to an inductor.

REVIEW QUESTIONS

1. An ac power circuit containing an inductor has a source voltage E_S of 150 V and a source current I_S of 0.5 A. Calculate the inductive reactance X_L of the inductor.

2. Consider an ac power circuit having a source frequency f and containing a single inductor. What happens to the inductive reactance X_L of the inductor when the source frequency f decreases to half the initial value?

3. How does inductive reactance X_L vary with inductance L ?

4. Consider an ac power circuit containing an ideal inductor. Determine the phase shift between the waveforms of the inductor voltage and current. Consider the inductor voltage as the reference.

5. How does the resistance of the wire coil in an actual inductor affect the phase shift between the inductor voltage and current?

Capacitive reactance

EXERCISE OBJECTIVE

When you have completed this exercise, you will know what a capacitor is. You will be able to calculate the capacitive reactance of a capacitor from its capacitance. You will know the relationship between the source frequency and the capacitive reactance of a capacitor. You will also know the effect of introducing a capacitor in an ac circuit on the voltage and current waveforms.

DISCUSSION OUTLINE

The Discussion of this exercise covers the following points:

- Capacitors and capacitive reactance
- Capacitive phase shift

DISCUSSION

Capacitors and capacitive reactance

Notice the differences: inductors store energy in a magnetic field and oppose current changes. Capacitors store energy in an electric field and oppose voltage changes.

A capacitor consists basically of two plates of a conductive material (generally a metal) separated by an insulating material. A pair of terminals on the capacitor provides access to the metal plates. When current flows through a capacitor, the capacitor stores energy in the electric field that builds up between the metal plates. As a result, capacitors oppose voltage changes.

The fundamental characteristic of any capacitor is the **capacitance** C , which is expressed in farads (F). Capacitance is one of the main factors that determine the opposition to current flow of the capacitor, i.e., the **capacitive reactance** X_C . Like resistance and inductive reactance, capacitive reactance is expressed in ohms (Ω). The equation for capacitive reactance is given below:

In practice, the capacitance C of a capacitor is generally expressed in μF .
 $1 \mu\text{F} = 0.000001 \text{ F}$.

$$X_C = \frac{1}{2\pi f C} \quad (2-2)$$

where X_C is the capacitive reactance of the capacitor, expressed in ohms (Ω).
 f is the frequency of the ac power source, expressed in hertz (Hz).
 C is the capacitance of the capacitor, expressed in farads (F).

Equation (2-2) shows that the capacitive reactance X_C of a capacitor is inversely proportional to the capacitance C and the frequency f of the ac power source.

Ohm's law states that the current I flowing in a capacitor is equal to E/X_C . Therefore, the higher the capacitive reactance of the capacitor, the lower the capacitor current.

Capacitive phase shift

Another fundamental characteristic of a capacitor is that the sine wave of the current flowing in the capacitor leads the sine wave of the voltage across the capacitor by 90° . Figure 2-5 shows the typical voltage and current waveforms related to a capacitor and the corresponding phasors.

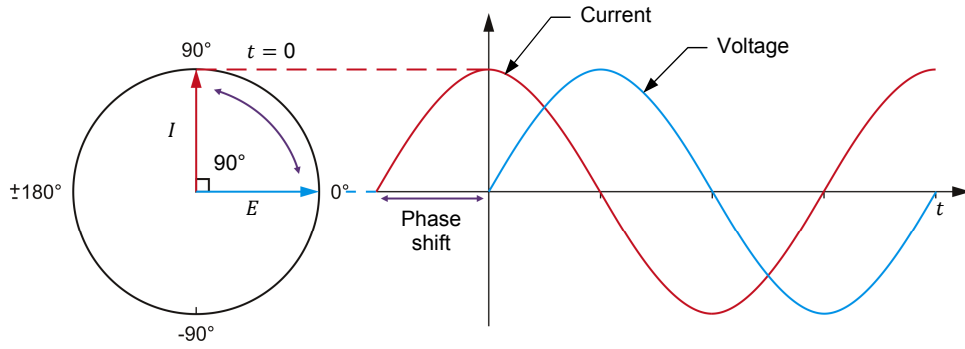

Figure 2-5. Voltage and current waveforms related to a capacitor and corresponding phasors.

Contrary to inductors, the difference between ideal and actual capacitors is negligible. This is because the resistance of the plates and terminals composing a capacitor is very low and has little influence on the phase shift between the capacitor voltage and current waveforms. The actual phase shift between the capacitor voltage and current waveforms is thus very close to 90° .

PROCEDURE OUTLINE

The Procedure is divided into the following sections:

- Setup and connections
- Capacitance and capacitive reactance
- Effect of the frequency on the capacitive reactance
- Measuring the capacitive phase shift

PROCEDURE



High voltages are present in this laboratory exercise. Do not make or modify any banana jack connections with the power on unless otherwise specified.

Setup and connections

In this section, you will connect an ac circuit containing a capacitor and set up the equipment to measure the voltage E_C across the capacitor and the current I_C flowing through the capacitor.

1. Refer to the Equipment Utilization Chart in Appendix A to obtain the list of equipment required to perform this exercise.

Install the required equipment in the [Workstation](#).

2. Make sure that the main power switch on the **Four-Quadrant Dynamometer/Power Supply** is set to the **O** (off) position, then connect its **Power Input** to an ac power outlet.

Connect the **Power Input** of the **Data Acquisition and Control Interface** to a 24 V ac power supply. Turn the 24 V ac power supply on.

3. Connect the USB port of the **Data Acquisition and Control Interface** to a USB port of the host computer.

Connect the USB port of the **Four-Quadrant Dynamometer/Power Supply** to a USB port of the host computer.

4. Turn the **Four-Quadrant Dynamometer/Power Supply** on, then set the **Operating Mode** switch to **Power Supply**.

5. Turn the host computer on, then start the **LVDAC-EMS** software.

In the **LVDAC-EMS Start-Up** window, make sure that the **Data Acquisition and Control Interface** and the **Four-Quadrant Dynamometer/Power Supply** are detected. Make sure that the **Computer-Based Instrumentation** function for the **Data Acquisition and Control Interface** is available. Select the network voltage and frequency that correspond to the voltage and frequency of your local ac power network, then click the **OK** button to close the **LVDAC-EMS Start-Up** window.

6. Set up the circuit shown in Figure 2-6.

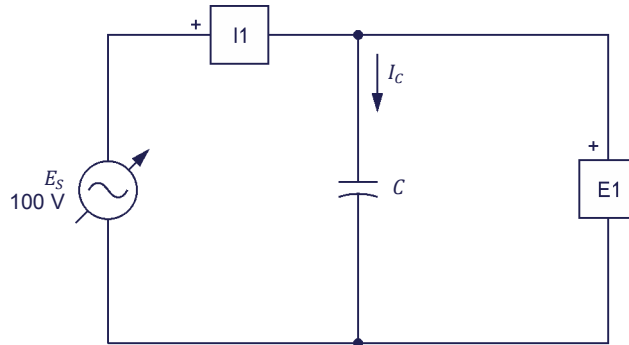

Figure 2-6. AC circuit containing a capacitor.

The value of the capacitance C to be used in the circuit of Figure 2-6 depends on the frequency of the ac power source, as indicated in Table 2-3.

Table 2-3. First and second capacitance values for frequencies of 50 Hz and 60 Hz.

Power source frequency (Hz)	Capacitance C (μF)	
	First value	Second value
50	10.6	5.3
60	8.8	4.4

Use inputs $E1$ and $I1$ of the Data Acquisition and Control Interface to measure the capacitor voltage E_C and current I_C , respectively.

7. In LVDAC-EMS, open the Four-Quadrant Dynamometer/Power Supply window, then make the following settings:
 - Set the *Function* parameter to *AC Power Source*.
 - Make sure that the *Voltage Control* parameter is set to *Knob*. This allows the ac power source to be controlled manually.
 - Set the *No Load Voltage* parameter to 100 V.
 - Set the *Frequency* parameter to the frequency of your local ac power network.
 - Leave the other parameters set as they are.

Make the necessary switch settings on the Capacitive Load (or on the Inductive and Capacitive Loads) in order to obtain the first capacitance value required (refer to Table 2-3).

Capacitance and capacitive reactance

In this section, you will calculate the capacitive reactance X_C of the capacitor for the first value of capacitance C in Table 2-3. You will measure the capacitor voltage E_C and current I_C . You will then determine the capacitive reactance X_C of the capacitor from the measured capacitor voltage E_C and current I_C and compare the result to the calculated capacitive reactance X_C . You will decrease the capacitance C to half its initial value to determine the effect on the capacitive reactance X_C of the capacitor.

8. Calculate the capacitive reactance X_C of the capacitor for the first value of capacitance C in Table 2-3 and record the result below.

Calculated capacitive reactance $X_C = \underline{\hspace{2cm}} \Omega$

9. In the Four-Quadrant Dynamometer/Power Supply window, enable the ac power source.

10. In LVDAC-EMS, open the **Metering** window. Set meters **E1** and **I1** to measure the rms values of the capacitor voltage E_C and current I_C , respectively.

In the **Four-Quadrant Dynamometer/Power Supply** window, readjust the value of the **No Load Voltage** parameter so that the ac power source voltage E_S (indicated by meter **E1** in the **Metering** window) is equal to 100 V.

Record below the measured values of the capacitor voltage E_C and current I_C (meters **E1** and **I1**, respectively).

Capacitor voltage $E_C =$ _____ V

Capacitor current $I_C =$ _____ A

11. Calculate the capacitive reactance X_C of the capacitor using the capacitor voltage E_C and current I_C measured in the previous step.

Capacitive reactance $X_C =$ _____ Ω

12. Compare the capacitive reactance X_C obtained in the previous step with the calculated capacitive reactance X_C recorded in step 8. Are the values close to each other?

Yes No

13. Set the capacitance C of the capacitor to the second value indicated in Table 2-3 by making the necessary switch settings on the **Capacitive Load**.

In the **Four-Quadrant Dynamometer/Power Supply** window, readjust the value of the **No Load Voltage** parameter, if necessary, so that the ac power source voltage E_S (indicated by meter **E1** in the **Metering** window) is equal to 100 V.

14. Calculate the capacitive reactance X_C of the capacitor for the second value of capacitance C in Table 2-3 and record the result in the proper cell of the second column in Table 2-4 (see next procedure section).

15. In the **Metering** window, measure the rms values of the capacitor voltage E_C and current I_C . Record the values in the proper cells of the third and fourth columns in Table 2-4.

16. Calculate the capacitive reactance X_C of the capacitor using the capacitor voltage E_C and current I_C measured in the previous step. Record the result in the proper cell of the fifth column in Table 2-4.

17. Compare the capacitive reactance X_C obtained in the previous step with the calculated capacitive reactance X_C recorded in step 14. Are the values close to each other?

Yes No

18. Compare the capacitive reactance X_C of the capacitor obtained with the first capacitance value to the capacitive reactance X_C obtained with the second capacitance value. What happened to the capacitive reactance X_C of the capacitor when you decreased the capacitance C to half its initial value? Describe the relationship between the capacitance C and the capacitive reactance X_C of a capacitor.

Effect of the frequency on the capacitive reactance

In this section, you will calculate the capacitive reactance X_C of the capacitor using the second value of capacitance C in Table 2-3, for ac power source frequencies of 40 Hz and 70 Hz. For each of these two frequencies, you will measure the capacitor voltage E_C and current I_C , calculate from these measured values the capacitive reactance X_C of the capacitor, and compare the results with the corresponding calculated capacitive reactance X_C . Using the capacitive reactance values calculated from the measured capacitive voltages and currents, you will determine the relationship between the source frequency f and the capacitive reactance X_C .

19. Calculate the capacitive reactance X_C of the capacitor (using the second value of capacitance C indicated in Table 2-3) at frequencies of 40 and 70 Hz. Record the results in the proper cells of the second column in Table 2-4.

Table 2-4. Calculated capacitive reactance and measured voltage E_C , current I_C , and capacitive reactance for various frequencies.

Power source frequency (Hz)	Calculated capacitive reactance X_C (Ω)	Capacitor voltage E_C (V)	Capacitor current I_C (A)	Capacitive reactance X_C (Ω)
40				
50 or 60				
70				

20. In the **Four-Quadrant Dynamometer/Power Supply** window, set the **Frequency** parameter to 40 Hz.

21. In the **Metering** window, measure the rms values of the capacitor voltage E_C and current I_C and record the values in the proper cells of the third and fourth columns in Table 2-4.
 22. Calculate the capacitive reactance X_C of the capacitor from the capacitor voltage E_C and current I_C measured in the previous step. Record the result in the proper cell of the fifth column in Table 2-4.
 23. In the **Four-Quadrant Dynamometer/Power Supply** window, set the **Frequency** parameter to 70 Hz, then repeat steps 21 and 22.
 24. Determine the relationship between the capacitive reactance X_C of a capacitor and the ac power source frequency using the values recorded in Table 2-4.
-
-

Measuring the capacitive phase shift

In this section, you will observe the waveforms of the capacitor voltage and current using the Oscilloscope to determine the phase shift between these parameters. Then, using the Phasor Analyzer, you will measure the phase shift between the capacitor voltage phasor and the capacitor current phasor, and compare the result to the phase shift you determined from the voltage and current waveforms.

25. In the **Four-Quadrant Dynamometer/Power Supply** window, set the **Frequency** parameter to the frequency of your local ac power network.
26. In **LVDAC-EMS**, open the **Oscilloscope** and display the capacitor voltage and current on channels 1 and 2, respectively. If necessary, set the time base to display at least two cycles of the waveforms. Select channel 1 (capacitor voltage) as the trigger source then set the trigger level to 0 V.

Notice that the amplitude of the capacitor voltage waveform is equivalent to the rms value of the capacitor voltage E_C indicated in the **Metering** window. Also notice that the amplitude of the capacitor current waveform is equivalent to the rms value of the capacitor current I_C indicated in the **Metering** window.

27. Does the sine wave of the capacitor current lead the sine wave of the capacitor voltage?

Yes No

28. Using the **Oscilloscope**, determine the period T of the waveforms of the capacitor voltage and the capacitor current. Record the value below.

Period $T =$ _____ ms

29. Using the **Oscilloscope**, determine the time interval d between the capacitor voltage and the capacitor current, then calculate the phase shift between the two waveforms.

Consider the capacitor voltage waveform as the reference.

Time interval $d =$ _____ ms

Phase shift $= \frac{d}{T} \times 360 =$ _____ °

30. In **LVDAC-EMS**, open the **Phasor Analyzer** and display the capacitor voltage E_C (input **E1**) and current I_C (input **I1**). Set the **Reference Phasor** parameter to the capacitor voltage E_C (input **E1**). Record the phase shift between the capacitor voltage phasor and capacitor current phasor below. Indicate whether the phasor of the capacitor current I_C leads or lags the phasor of the capacitor voltage E_C .

Phase shift = _____ °

31. Compare the phase shift you determined from the capacitor voltage and current waveforms with the phase shift measured from the corresponding phasors of the capacitor voltage and current. Are both values close to each other?

Yes No

32. In the **Four-Quadrant Dynamometer/Power Supply** window, disable the ac power source.

33. Close **LVDAC-EMS**, then turn off all the equipment. Disconnect all leads and return them to their storage location.

CONCLUSION

In this exercise, you learned what a capacitor is. You also learned how to calculate the capacitive reactance of a capacitor from its capacitance. You saw the relationship between the source frequency and the capacitive reactance of a capacitor. You verified the phase shift between the voltage and current related to a capacitor.

REVIEW QUESTIONS

1. An ac power circuit containing a capacitor ($C = 12 \mu\text{F}$) has a source frequency f of 60 Hz. Calculate the capacitive reactance X_C of the capacitor.

2. Consider an ac power circuit having a source frequency f and containing a single capacitor. What happens to the capacitive reactance X_C of the capacitor when the source frequency f decreases to half its initial value?

3. How does capacitive reactance X_C vary with capacitance C ?

4. Consider an ac power circuit containing a capacitor. Determine the phase shift between the waveforms of the capacitor voltage and current. Consider the capacitor voltage as the reference.

5. An ac power circuit containing a capacitor has a source voltage E_S of 120 V, a source current I_S of 1.5 A, and a power source frequency f of 60 Hz. Calculate the capacitance C of the capacitor.

Impedance

EXERCISE OBJECTIVE

When you have completed this exercise, you will be familiar with the phasor diagrams related to a resistor, an inductor, and a capacitor. You will be able to calculate the equivalent reactance of reactive components in series ac circuits and represent the equivalent reactance on a phasor diagram. You will also know how to calculate the impedance of series and parallel ac circuits and represent the equivalent impedance on a phasor diagram.

DISCUSSION OUTLINE

The Discussion of this exercise covers the following points:

- Phasor diagrams related to resistors, inductors, and capacitors
- Equivalent reactance of series-connected reactive components
- Impedance of resistors, inductors, and capacitors connected in series
- Impedance of resistors, inductors, and capacitors connected in parallel

DISCUSSION

Phasor diagrams related to resistors, inductors, and capacitors

Each parameter in an ac power circuit (e.g., voltage, current, power, etc.) can be represented as a phasor, i.e., a vector having its beginning at the origin (0, 0) of a cartesian plane. The length of the phasor is determined by the magnitude of the parameter that the phasor represents, while the angular position (direction) of the phasor is determined by the phase angle of the parameter. The horizontal axis of the plane is called the real-number axis, while the vertical axis of the plane is called the imaginary-number axis. The phasor diagrams related to basic components, i.e., the resistor, inductor, and capacitor, are introduced below.

Phasor diagram related to a resistor

The current flowing in a resistor is in phase with the voltage across the resistor (see Figure 1-17 in Exercise 1-3). Consequently, the resistance of a resistor ($R = E_R/I_R$) can be represented as a phasor that is in phase with the voltage and current phasors related to the resistor, as shown in Figure 2-7.



Vectorial calculations related to phasors are explained in more detail in Appendix D.

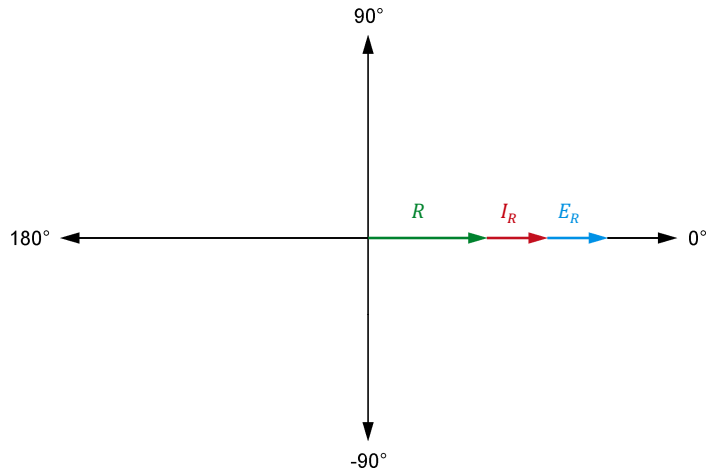

Figure 2-7. Phasor diagram of the voltage E_R , current I_R , and resistance R related to a resistor.

Phasor diagram related to an inductor

The current flowing in an ideal inductor lags the voltage across the inductor by 90° (as seen in Exercise 2-1). The inductive reactance of an inductor can be determined using vectorial calculation to solve the equation $X_L = E_L / I_L$. The result of this calculation (i.e., the inductive reactance X_L) is a phasor that leads the phasor of the inductor voltage E_L by 90° and that is 180° out of phase with respect to the phasor of the inductor current I_L , as shown in Figure 2-8.

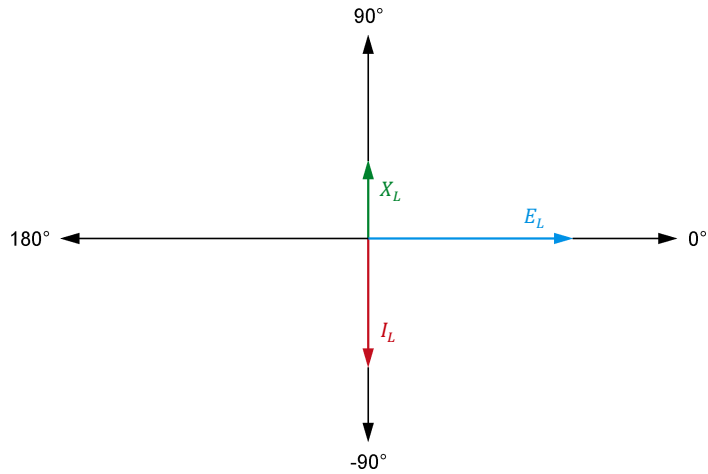

Figure 2-8. Phasor diagram of the voltage E_L , current I_L , and inductive reactance X_L related to an inductor.

Phasor diagram related to a capacitor

The current flowing in a capacitor leads the voltage across the capacitor by 90° (as seen in Exercise 2-2). The capacitive reactance of a capacitor can be determined using vectorial calculation to solve the equation $X_C = E_C/I_C$. The result of this calculation (i.e., the capacitive reactance X_C) is a phasor that lags the phasor of the capacitor voltage E_C by 90° and that is 180° out of phase with respect to the phasor of the capacitor current I_C , as shown in Figure 2-9.

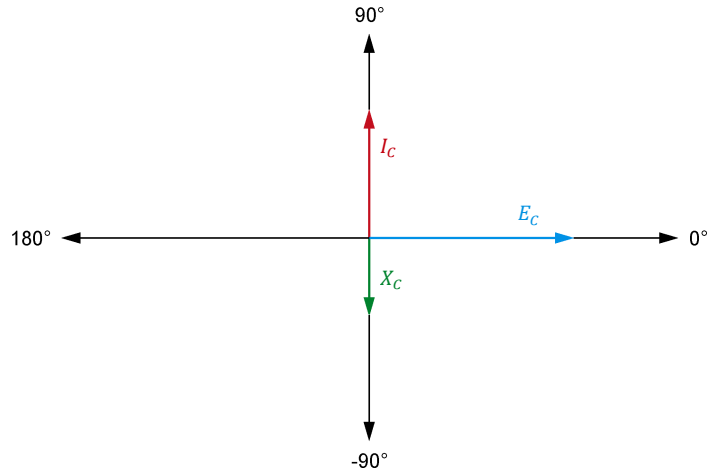

Figure 2-9. Phasor diagram of the voltage E_C , current I_C , and capacitive reactance X_C related to a capacitor.

Equivalent reactance of series-connected reactive components

The main difference between the phasor diagram related to an inductor and the phasor diagram related to a capacitor is the direction of the reactance phasor. Inductive reactance X_L and capacitive reactance X_C are both on the imaginary-number axis (vertical axis of diagram) but of opposite polarity. Consequently, when an inductor is in series with a capacitor in an ac power circuit, the inductive and capacitive reactance values cancel each other. The equivalent reactance $X_{Equi.}$ of an inductor and a capacitor in series is thus determined by the following equation:

$$X_{Equi.} = X_L - X_C \quad (2-3)$$

where $X_{Equi.}$ is the equivalent reactance of the inductor and the capacitor, expressed in ohms (Ω).

X_L is the inductive reactance of the inductor, expressed in ohms (Ω).

X_C is the capacitive reactance of the capacitor, expressed in ohms (Ω).

Equation (2-3) shows that, in a series ac circuit containing an inductor and a capacitor, if the inductive reactance X_L of the inductor has a higher value than the capacitive reactance X_C of the capacitor, then the equivalent reactance $X_{Equi.}$ of the inductor and capacitor is positive and said to be inductive. Consider, for example, a series ac circuit containing an inductor ($X_L = 300 \Omega$) and a capacitor ($X_C = 100 \Omega$). The equivalent reactance $X_{Equi.}$ of the inductor and capacitor is $+200 \Omega$ ($300 \Omega - 100 \Omega$), or 200Ω inductive, which means that the inductor and capacitor connected in series are equivalent to a single inductor having an inductive reactance X_L of 200Ω . The sine wave of the current I_X flowing through the reactive components thus lags the sine wave of the voltage E_X across the reactive components by 90° . Figure 2-10 shows the phasor diagram related to a series ac circuit containing an inductor and a capacitor, and having an inductive equivalent reactance.

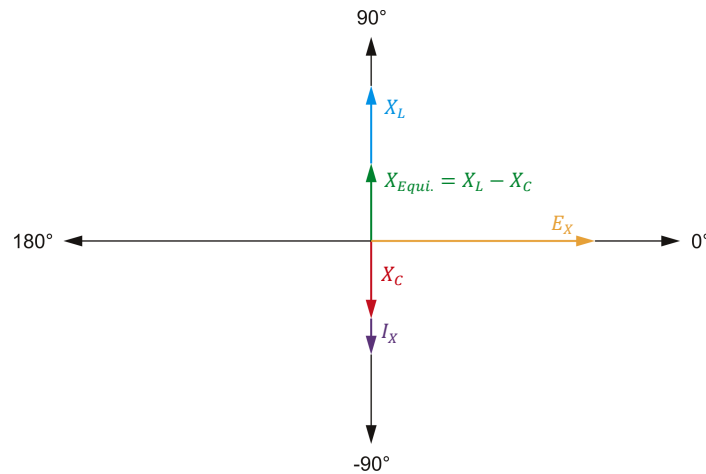

Figure 2-10. Phasor diagram related to a series ac circuit containing an inductor and a capacitor, and having an inductive equivalent reactance.

Conversely, Equation (2-3) shows that, in a series ac circuit containing an inductor and a capacitor, if the capacitive reactance X_C of the capacitor is higher than the inductive reactance X_L of the inductor, then the equivalent reactance $X_{Equi.}$ of the inductor and capacitor is negative and is said to be capacitive. Consider, for example, a series ac circuit containing an inductor ($X_L = 150 \Omega$) and a capacitor ($X_C = 250 \Omega$). The equivalent reactance $X_{Equi.}$ of the inductor and capacitor is -100Ω ($150 \Omega - 250 \Omega$), or 100Ω capacitive, which means that the inductor and capacitor connected in series are equivalent to a single capacitor having a capacitive reactance X_C of 100Ω . The sine wave of the current I_X flowing through the reactive components thus leads the sine wave of the voltage E_X across the reactive components by 90° . Figure 2-11 shows the phasor diagram related to a series ac circuit containing an inductor and a capacitor, and having a capacitive equivalent reactance.

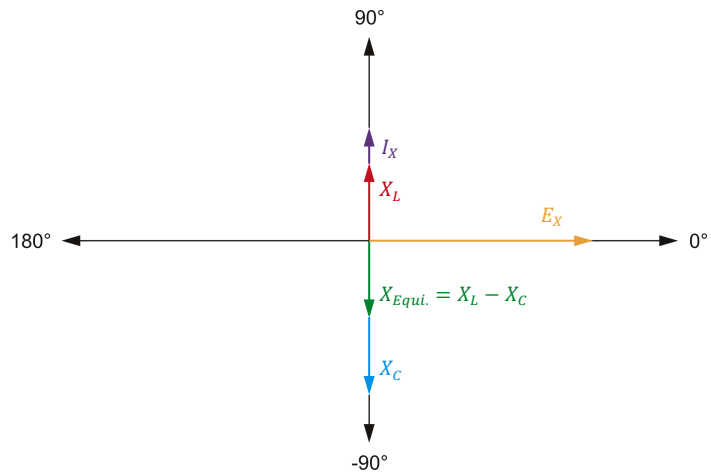

Figure 2-11. Phasor diagram related to a series ac circuit containing an inductor and a capacitor, and having a capacitive equivalent reactance.

Impedance of resistors, inductors, and capacitors connected in series

When a resistor and a reactive component (inductor or capacitor) are connected in series, the total opposition to current flow in the circuit, which is known as the impedance Z , is equal to the vectorial sum of the resistance R of the resistor and the reactance X of the reactive component. Figure 2-12 shows the phasor diagram related to the impedance Z of a resistor and an inductor connected in series.

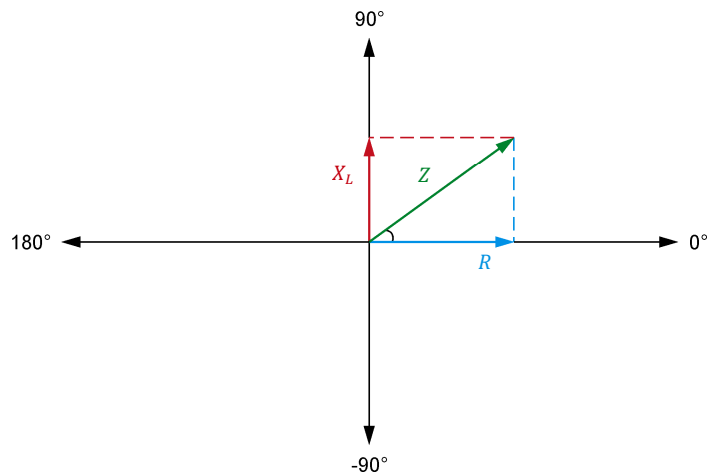

Figure 2-12. Phasor diagram showing the impedance Z of a resistor and an inductor connected in series.

Figure 2-12 clearly shows that the impedance Z results from the addition of the phasor of resistance R to the phasor of inductive reactance X_L . In fact, the phasor of impedance Z is the diagonal of the rectangle formed by the phasors of the resistance R and inductive reactance X_L . Therefore, following the Pythagorean Theorem, the impedance Z of a resistor in series with a reactive component can be calculated using the following equation:

$$Z = \sqrt{R^2 + X^2} \tag{2-4}$$

where Z is the impedance of the resistor and reactive component connected in series, expressed in ohms (Ω).

R is the resistance of the resistor, expressed in ohms (Ω).

X is the reactance of the reactive component, expressed in ohms (Ω).

Equation (2-4) is valid for inductors and capacitors. Figure 2-13 shows an example of the impedance Z resulting from a resistor and a capacitor connected in series.

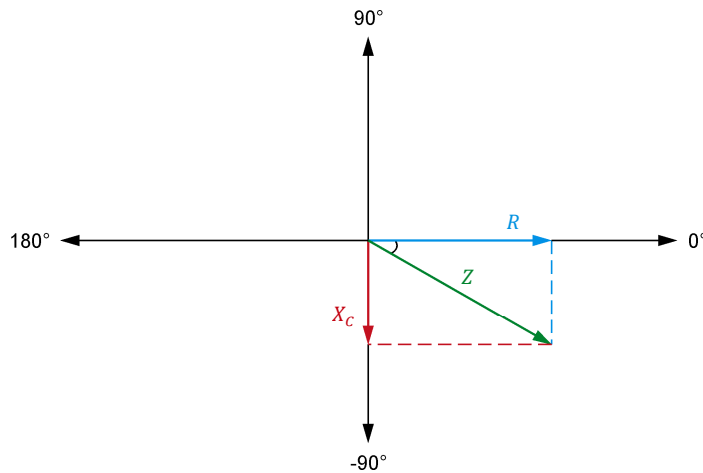
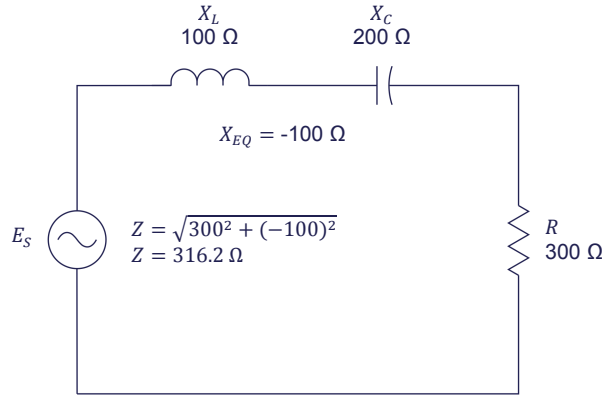
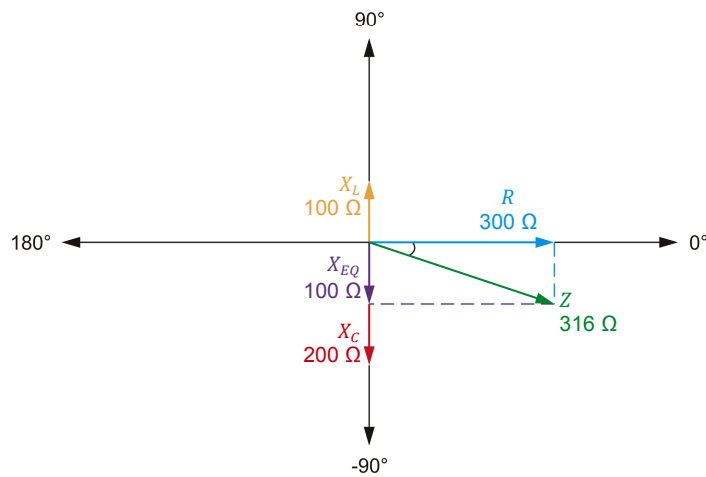

Figure 2-13. Phasor diagram showing the impedance Z of a resistor and a capacitor connected in series.

When more than one reactive component is connected in series with a resistor, it is necessary to calculate the equivalent circuit reactance $X_{Equi.}$ before calculating the impedance Z using Equation (2-4). Consider for example the ac circuit shown in Figure 2-14a. The equivalent reactance $X_{Equi.}$ of the inductor and the capacitor is -100Ω ($100 \Omega - 200 \Omega$). The impedance Z is thus equal to 316Ω ($\sqrt{300^2 + (-100)^2}$). Figure 2-14b shows the corresponding phasor diagram.



(a) AC circuit containing a resistor, an inductor, and a capacitor connected in series.



(b) Phasor diagram related to the impedance Z of an ac circuit containing a resistor, an inductor, and a capacitor.

Figure 2-14. Series ac circuit containing a resistor, an inductor, and a capacitor, and the resulting phasor diagram.

Impedance of resistors, inductors, and capacitors connected in parallel

The equivalent resistance $R_{Equi.}$ of two resistors in parallel is equal to:

$$R_{Equi.} = \frac{R_1 \cdot R_2}{R_1 + R_2} \quad (2-5)$$

Equation (2-5) can also be used to calculate the impedance of a resistor in parallel with a reactive component. The equation for calculating the impedance Z thus becomes: $Z = (R \cdot X)/(R + X)$. However, since the resistance R of the resistor and the reactance X of the reactive component are both phasors, the vectorial sum of R and X (i.e., the term $[R + X]$) in Equation (2-5) must be replaced by the term $\sqrt{R^2 + X^2}$. The resulting equation for calculating the

impedance Z of resistive and reactive components connected in parallel is given below:

$$Z = \frac{R \cdot X}{\sqrt{R^2 + X^2}} \quad (2-6)$$

where Z is the impedance of the resistor and reactive component connected in parallel, expressed in ohms (Ω).

For example, consider the ac circuit containing a resistor and an inductor shown in Figure 2-15. The impedance Z of this circuit is equal to:

$$Z = \frac{R \cdot X}{\sqrt{R^2 + X^2}} = \frac{250 \cdot 400}{\sqrt{250^2 + 400^2}} = 212 \Omega$$

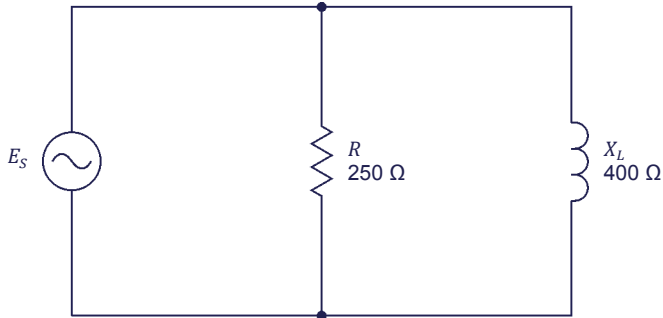

Figure 2-15. Parallel ac circuit containing a resistor and an inductor.

PROCEDURE OUTLINE

The Procedure is divided into the following sections:

- Setup and connections
- Equivalent reactance of a series LC circuit
- Impedance of a series RL circuit
- Impedance of a series RC circuit
- Impedance of a series RLC circuit
- Impedance of a parallel RL circuit
- Impedance of a parallel RC circuit

PROCEDURE



High voltages are present in this laboratory exercise. Do not make or modify any banana jack connections with the power on unless otherwise specified.

Setup and connections

In this section, you will connect a series ac circuit containing an inductor and a capacitor and set up the equipment to measure the voltage E_x and current I_x related to these components.

1. Refer to the Equipment Utilization Chart in Appendix A to obtain the list of equipment required to perform this exercise.

Install the required equipment in the [Workstation](#).

2. Make sure that the main power switch on the [Four-Quadrant Dynamometer/Power Supply](#) is set to the **O** (off) position, then connect its *Power Input* to an ac power outlet.

Connect the *Power Input* of the [Data Acquisition and Control Interface](#) to a 24 V ac power supply. Turn the 24 V ac power supply on.

3. Connect the USB port of the [Data Acquisition and Control Interface](#) to a USB port of the host computer.

Connect the USB port of the [Four-Quadrant Dynamometer/Power Supply](#) to a USB port of the host computer.

4. Turn the [Four-Quadrant Dynamometer/Power Supply](#) on, then set the *Operating Mode* switch to *Power Supply*.

5. Turn the host computer on, then start the [LVDAC-EMS](#) software.

In the [LVDAC-EMS Start-Up](#) window, make sure that the [Data Acquisition and Control Interface](#) and the [Four-Quadrant Dynamometer/Power Supply](#) are detected. Make sure that the *Computer-Based Instrumentation* function for the [Data Acquisition and Control Interface](#) is available. Select the network voltage and frequency that correspond to the voltage and frequency of your local ac power network, then click the **OK** button to close the [LVDAC-EMS Start-Up](#) window.

6. Set up the circuit shown in Figure 2-16.

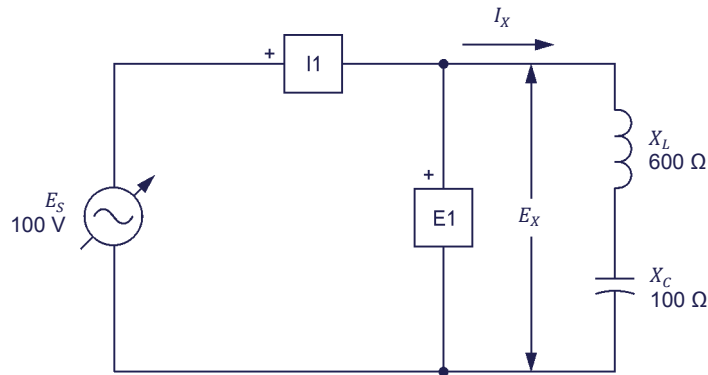

Figure 2-16. Series ac circuit containing an inductor and a capacitor.

Make the necessary switch settings on the [Inductive Load](#) and [Capacitive Load](#) (or on the [Inductive and Capacitive Loads](#)) in order to obtain the inductive and capacitive reactance values required. The voltage E_X is the voltage across the inductor and capacitor and the current I_X is the current flowing through the inductor and capacitor.

Use inputs $E1$ and $I1$ of the [Data Acquisition and Control Interface](#) to measure the voltage E_X and current I_X , respectively.

7. In [LVDAC-EMS](#), open the [Four-Quadrant Dynamometer/Power Supply](#) window, then make the following settings:
- Set the [Function](#) parameter to [AC Power Source](#).
 - Make sure that the [Voltage Control](#) parameter is set to [Knob](#). This allows the ac power source to be controlled manually.
 - Set the [No Load Voltage](#) parameter to 100 V.
 - Set the [Frequency](#) parameter to the frequency of your local ac power network.
 - Leave the other parameters set as they are.

Equivalent reactance of a series LC circuit

In this section, you will calculate the equivalent reactance $X_{Equi.}$ of the reactive components in the circuit of Figure 2-16. You will measure the voltage E_X and current I_X and calculate the equivalent reactance $X_{Equi.}$ from these values. Using the Oscilloscope, you will determine the phase relationship between the voltage E_X and current I_X and whether the equivalent reactance is inductive or capacitive. You will then interchange the inductive and capacitive reactance values in the circuit and repeat the previous manipulations. You will determine the relationship between the polarity of the equivalent reactance $X_{Equi.}$ of the reactive components and the nature of the equivalent reactance (inductive or capacitive).

8. Calculate the equivalent reactance $X_{Equi.}$ of the reactive components.

Equivalent reactance $X_{Equi.} = \underline{\hspace{2cm}} \Omega$

9. In the **Four-Quadrant Dynamometer/Power Supply** window, enable the ac power source.

10. In **LVDAC-EMS**, open the **Metering** window. Set meters **E1** and **I1** to measure the rms values of the voltage E_X and current I_X , respectively.

In the **Four-Quadrant Dynamometer/Power Supply** window, readjust the value of the **No Load Voltage** parameter so that the ac power source voltage E_S (indicated by meter **E1** in the **Metering** window) is equal to 100 V.

Record below the rms values of the voltage E_X and current I_X (meters **E1** and **I1**, respectively).

Voltage $E_X = \underline{\hspace{2cm}} \text{ V}$

Current $I_X = \underline{\hspace{2cm}} \text{ A}$

11. Calculate the equivalent reactance $X_{Equi.}$ of the inductor and capacitor using the voltage E_X and current I_X measured in the previous step.

Equivalent reactance $X_{Equi.} = \underline{\hspace{2cm}} \Omega$

12. Compare the equivalent reactance $X_{Equi.}$ obtained in the previous step with the calculated equivalent reactance $X_{Equi.}$ recorded in step 8. Are the values equal?

Yes No

13. In **LVDAC-EMS**, open the **Oscilloscope** and display the voltage E_X and current I_X on channels 1 and 2, respectively. Set the time base to display at least two cycles of the waveforms. Select channel 1 (voltage E_X) as the trigger source then set the trigger level to 0 V.

14. Using the **Oscilloscope**, determine the phase relationship between the voltage E_x and current I_x . Is the equivalent reactance $X_{Equi.}$ of the inductor and capacitor inductive or capacitive?

15. In the **Four-Quadrant Dynamometer/Power Supply** window, disable the ac power source.

16. Make the necessary switch settings on the **Inductive Load** and **Capacitive Load** (or on the **Inductive and Capacitive Loads**) in order to obtain the values of inductive reactance X_L and capacitive reactance X_C indicated in the circuit of Figure 2-17.

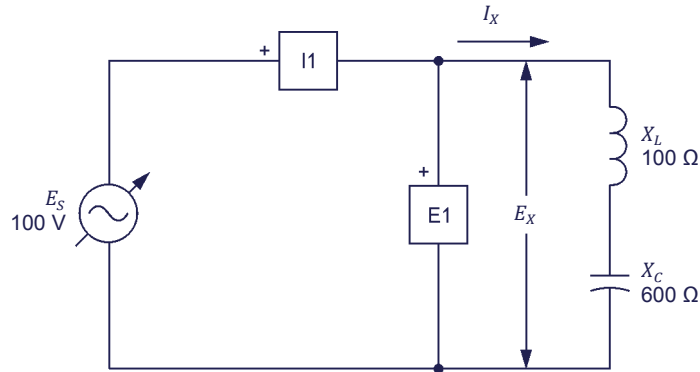

Figure 2-17. Series ac circuit containing an inductor and a capacitor.

17. Calculate the equivalent reactance $X_{Equi.}$ of the inductor and capacitor.

Equivalent reactance $X_{Equi.} = \underline{\hspace{2cm}} \Omega$

18. In the **Four-Quadrant Dynamometer/Power Supply** window, enable the ac power source.

In the **Four-Quadrant Dynamometer/Power Supply** window, readjust the value of the **No Load Voltage** parameter so that the ac power source voltage E_S (indicated by meter **E1** in the **Metering** window) is equal to 100 V.

19. In the **Metering** window, measure the rms values of the voltage E_x and current I_x , and record the values below.

Voltage $E_x = \underline{\hspace{2cm}} \text{ V}$

Current $I_x = \underline{\hspace{2cm}} \text{ A}$

20. Calculate the equivalent reactance $X_{E_{\text{equi.}}}$ of the inductor and capacitor using the voltage E_X and current I_X measured in the previous step.

Equivalent reactance $X_{E_{\text{equi.}}} = \underline{\hspace{2cm}} \Omega$

21. Compare the equivalent reactance $X_{E_{\text{equi.}}}$ obtained in the previous step with the calculated equivalent reactance $X_{E_{\text{equi.}}}$ recorded in step 17. Are the values virtually equal?

Yes No

22. Using the **Oscilloscope**, determine the phase relationship between the voltage E_X and current I_X . Is the equivalent reactance $X_{E_{\text{equi.}}}$ of the inductor and capacitor inductive or capacitive?

23. Do your observations in this section confirm the relationship between the polarity of the calculated equivalent reactance $X_{E_{\text{equi.}}}$ and the nature of the equivalent reactance (inductive or capacitive) observed? Explain.

Impedance of a series RL circuit

In this section, you will set up a series ac circuit containing a resistor and an inductor. You will calculate the impedance Z of the resistor and inductor. You will then measure the voltage E_Z and current I_Z related to these components. You will calculate the impedance Z of the resistor and inductor from the measured voltage and current then compare the result with the calculated impedance Z .

24. In the **Four-Quadrant Dynamometer/Power Supply** window, disable the ac power source.

25. Set up the circuit shown in Figure 2-18.

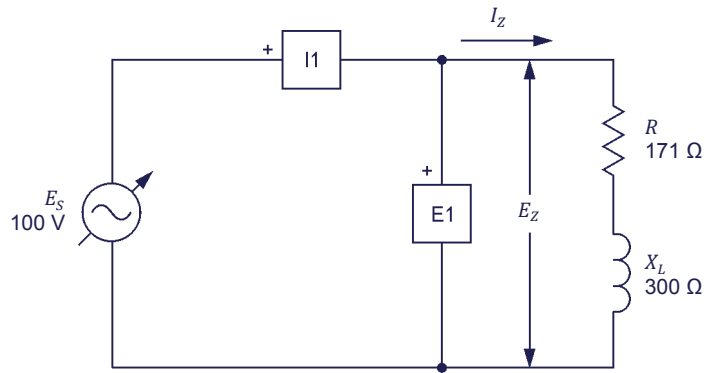

Figure 2-18. Series ac circuit containing a resistor and an inductor.

Make the necessary switch settings on the **Resistive Load** and **Inductive Load** (or on the **Inductive and Capacitive Loads**) in order to obtain the resistance and inductive reactance values required.

Use inputs **E1** and **I1** of the **Data Acquisition and Control Interface** to measure the voltage E_Z and current I_Z , respectively.

26. Calculate the impedance Z of the resistor and inductor.

Impedance $Z = \underline{\hspace{2cm}} \Omega$

27. In the **Four-Quadrant Dynamometer/Power Supply** window, enable the ac power source.

In the **Four-Quadrant Dynamometer/Power Supply** window, readjust the value of the **No Load Voltage** parameter so that the ac power source voltage E_S (indicated by meter **E1** in the **Metering** window) is equal to 100 V.

28. In the **Metering** window, measure the rms values of the voltage E_Z and current I_Z , and record the values below.

Voltage $E_Z = \underline{\hspace{2cm}} \text{ V}$ Current $I_Z = \underline{\hspace{2cm}} \text{ A}$

29. Calculate the impedance Z of the resistor and inductor using the voltage E_Z and current I_Z measured in the previous step.

Impedance $Z = \underline{\hspace{2cm}} \Omega$

30. Compare the impedance Z obtained in the previous step with the calculated impedance Z recorded in step 26. Are both values close to each other?

Yes No

Impedance of a series RC circuit

In this section, you will set up a series ac circuit containing a resistor and a capacitor. You will calculate the impedance Z of the resistor and capacitor. You will then measure the voltage E_Z and current I_Z related to these components. You will calculate the impedance Z of the resistor and capacitor from the measured voltage and current then compare the result with the calculated impedance Z .

31. In the **Four-Quadrant Dynamometer/Power Supply** window, disable the ac power source.

32. Set up the circuit shown in Figure 2-19.

Make the necessary switch settings on the **Resistive Load** and **Capacitive Load** (or on the **Inductive and Capacitive Loads**) in order to obtain the resistance and capacitive reactance values required.

Use inputs **E1** and **I1** of the **Data Acquisition and Control Interface** to measure the voltage E_Z and current I_Z , respectively.

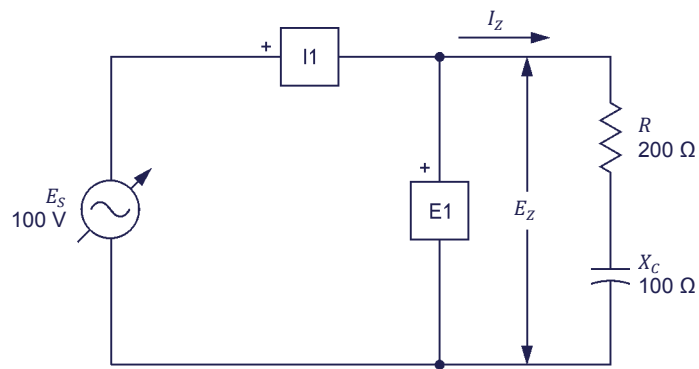

Figure 2-19. Series ac circuit containing a resistor and a capacitor.

33. Calculate the impedance Z of the resistor and capacitor.

Impedance $Z = \underline{\hspace{2cm}} \Omega$

34. In the **Four-Quadrant Dynamometer/Power Supply** window, enable the ac power source.

In the **Four-Quadrant Dynamometer/Power Supply** window, readjust the value of the **No Load Voltage** parameter so that the ac power source voltage E_S (indicated by meter **E1** in the **Metering** window) is equal to 100 V.

35. In the **Metering** window, measure the rms values of the voltage E_Z and current I_Z , and record the values below.

Voltage $E_Z = \underline{\hspace{2cm}} \text{ V}$

Current $I_Z = \underline{\hspace{2cm}} \text{ A}$

36. Calculate the impedance Z of the resistor and capacitor using the voltage E_Z and current I_Z measured in the previous step.

Impedance $Z = \underline{\hspace{2cm}} \Omega$

37. Compare the impedance Z obtained in the previous step with the calculated impedance Z recorded in step 33. Are both values close to each other?

Yes No

Impedance of a series RLC circuit

In this section, you will set up a series ac circuit containing a resistor, an inductor, and a capacitor. You will calculate the impedance Z of the resistor, inductor, and capacitor. You will then measure the voltage E_Z and current I_Z related to these components. You will calculate the impedance Z of the resistor, inductor, and capacitor from the measured voltage and current then compare the result with the calculated impedance Z .

38. In the **Four-Quadrant Dynamometer/Power Supply** window, disable the ac power source.

39. Set up the circuit shown in Figure 2-20.

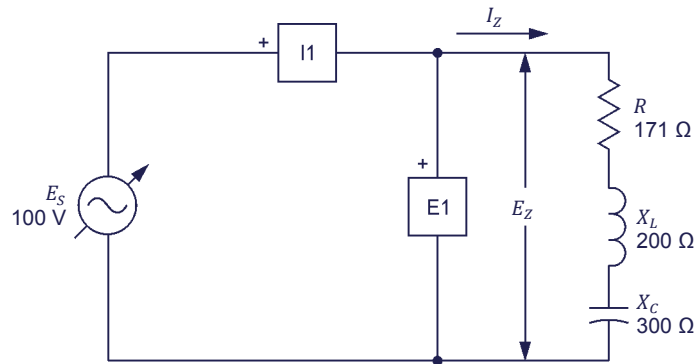

Figure 2-20. Series ac circuit containing a resistor, an inductor, and a capacitor.

Make the necessary switch settings on the **Resistive Load**, and on the **Inductive Load** and **Capacitive Load** (or on the **Inductive and Capacitive Loads**) in order to obtain the resistance, inductive reactance, and capacitive reactance values required.

Use inputs **E1** and **I1** of the **Data Acquisition and Control Interface** to measure the voltage E_Z and current I_Z , respectively.

40. Calculate the impedance Z of the resistor, inductor, and capacitor.

Impedance $Z =$ _____ Ω

41. In the **Four-Quadrant Dynamometer/Power Supply** window, enable the ac power source.

In the **Four-Quadrant Dynamometer/Power Supply** window, readjust the value of the **No Load Voltage** parameter so that the ac power source voltage E_s (indicated by meter **E1** in the **Metering** window) is equal to 100 V.

42. In the **Metering** window, measure the rms values of the voltage E_Z and current I_Z , and record the values below.

Voltage $E_Z =$ _____ V

Current $I_Z =$ _____ A

43. Calculate the impedance Z of the resistor, inductor, and capacitor using the voltage E_Z and current I_Z measured in the previous step.

Impedance $Z =$ _____ Ω

44. Compare the impedance Z obtained in the previous step with the calculated impedance Z recorded in step 40. Are both values close to each other?

Yes No

Impedance of a parallel RL circuit

In this section, you will set up a parallel ac circuit containing a resistor and an inductor. You will calculate the impedance Z of the resistor and inductor. You will then measure the voltage E_Z and current I_Z related to these components. You will calculate the impedance Z of the resistor and inductor from the measured voltage and current then compare the result with the calculated impedance Z .

45. In the **Four-Quadrant Dynamometer/Power Supply** window, disable the ac power source.

46. Set up the circuit shown in Figure 2-21.

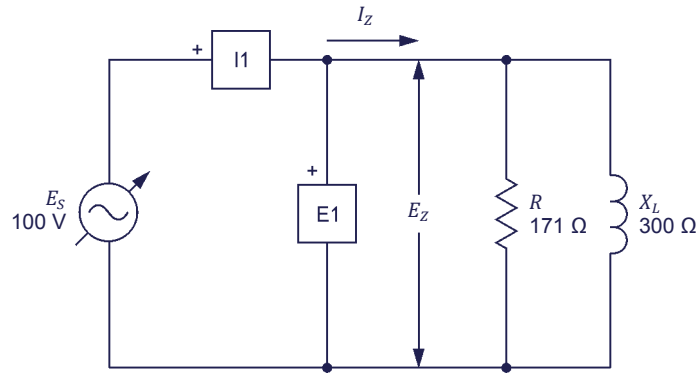

Figure 2-21. Parallel ac circuit containing a resistor and an inductor.

Make the necessary switch settings on the **Resistive Load** and **Inductive Load** (or on the **Inductive and Capacitive Loads**) in order to obtain the resistance and inductive reactance values required.

Use inputs **E1** and **I1** of the **Data Acquisition and Control Interface** to measure the voltage E_Z and current I_Z , respectively.

47. Calculate the impedance Z of the resistor and inductor.

Impedance $Z = \underline{\hspace{2cm}} \Omega$

48. In the **Four-Quadrant Dynamometer/Power Supply** window, enable the ac power source.

In the **Four-Quadrant Dynamometer/Power Supply** window, readjust the value of the **No Load Voltage** parameter so that the ac power source voltage E_S (indicated by meter **E1** in the **Metering** window) is equal to 100 V.

49. In the **Metering** window, measure the rms values of the voltage E_Z and current I_Z , and record the values below.

Voltage $E_Z = \underline{\hspace{2cm}} \text{ V}$

Current $I_Z = \underline{\hspace{2cm}} \text{ A}$

50. Calculate the impedance Z of the resistor and inductor using the voltage E_Z and current I_Z measured in the previous step.

Impedance $Z = \underline{\hspace{2cm}} \Omega$

51. Compare the impedance Z obtained in the previous step to the calculated impedance Z recorded in step 47. Are both values close to each other?

Yes No

Impedance of a parallel RC circuit

In this section, you will set up a parallel ac circuit containing a resistor and a capacitor. You will calculate the impedance Z of the resistor and capacitor. You will then measure the voltage E_Z and current I_Z related to these components. You will calculate the impedance Z of the resistor and capacitor from the measured voltage and current then compare the result with the calculated impedance Z .

52. In the **Four-Quadrant Dynamometer/Power Supply** window, disable the ac power source.

53. Set up the circuit shown in Figure 2-22.

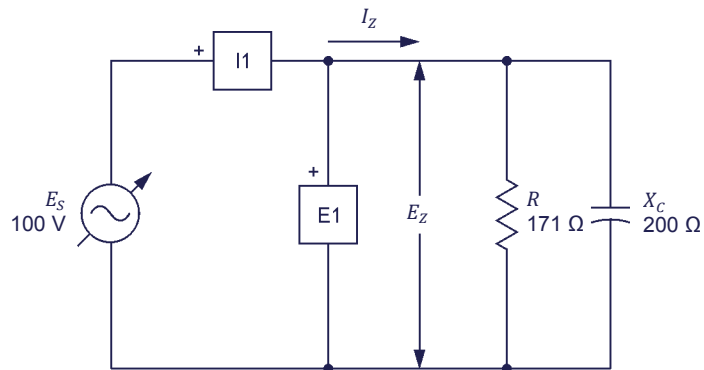

Figure 2-22. Parallel ac circuit containing a resistor and a capacitor.

Make the necessary switch settings on the **Resistive Load** and **Capacitive Load** (or on the **Inductive and Capacitive Loads**) in order to obtain the resistance and capacitive reactance values required.

Use inputs **E1** and **I1** of the **Data Acquisition and Control Interface** to measure the voltage E_Z and current I_Z , respectively.

54. Calculate the impedance Z of the resistor and capacitor.

Impedance $Z = \underline{\hspace{2cm}} \Omega$

55. In the **Four-Quadrant Dynamometer/Power Supply** window, enable the ac power source.

In the **Four-Quadrant Dynamometer/Power Supply** window, readjust the value of the **No Load Voltage** parameter so that the ac power source voltage E_S (indicated by meter **E1** in the **Metering** window) is equal to 100 V.

56. In the **Metering** window, measure the rms values of the voltage E_Z and current I_Z , and record the values below.

Voltage $E_Z =$ _____ V

Current $I_Z =$ _____ A

57. Calculate the impedance Z of the resistor and capacitor using the voltage E_Z and current I_Z measured in the previous step.

Impedance $Z =$ _____ Ω

58. Compare the impedance Z obtained in the previous step to the calculated impedance Z recorded in step 54. Are both values close to each other?

Yes No

59. In the **Four-Quadrant Dynamometer/Power Supply** window, disable the ac power source.

60. Close **LVDAC-EMS**, then turn off all the equipment. Disconnect all leads and return them to their storage location.

CONCLUSION

In this exercise, you became familiar with the phasor diagrams related to a resistor, an inductor, and a capacitor. You learned how to calculate the equivalent reactance of reactive components in series ac circuits and represent the equivalent reactance on a phasor diagram. You also learned how to calculate the impedance of series and parallel ac circuits and represent the impedance on a phasor diagram.

REVIEW QUESTIONS

1. Define impedance.

2. Consider a series ac circuit containing an inductor and a capacitor. Knowing that the equivalent reactance X_{Equi} of the reactive components has a negative value, determine the phase relationship between the source voltage and current. Is the equivalent reactance inductive or capacitive?

3. Determine the total impedance Z of a series ac circuit containing a resistor ($R = 250 \Omega$), an inductor ($X_L = 150 \Omega$), and a capacitor ($X_C = 200 \Omega$).

4. Determine the total impedance Z of an ac circuit containing a resistor ($R = 350 \Omega$) connected in parallel with two reactive components connected in series: an inductor ($X_L = 300 \Omega$) and a capacitor ($X_C = 150 \Omega$).

5. In an ac circuit containing a reactive component, what is the phase relationship between the phasor of the reactance X and the phasor of the source current I_S ?

Unit Test

- In an ac circuit containing an ideal inductor, the inductor current:
 - lags the inductor voltage by 90° .
 - leads the inductor voltage by 180° .
 - lags the inductor voltage by 180° .
 - leads the inductor voltage by 90° .
- Given a parallel ac circuit containing a resistor ($R = 200 \Omega$) and an inductor ($X_C = 350 \Omega$), calculate the impedance Z of the circuit.
 - $Z = 127 \Omega$
 - $Z = 403 \Omega$
 - $Z = 265 \Omega$
 - $Z = 174 \Omega$
- The inductance L of an inductor is directly proportional to the:
 - ac power source frequency f and inductance L .
 - current I and voltage E .
 - impedance Z of the circuit and inductance L .
 - ac power source frequency f and voltage E .
- Which equation determines the reactance X_C of a capacitor?
 - $X_C = E/2\pi I$
 - $X_C = 2\pi f C$
 - $X_C = 1/2\pi f C$
 - $X_C = \sqrt{R^2 + C^2}$
- In an ac circuit containing a capacitor, the capacitor current:
 - lags the capacitor voltage by 90° .
 - leads the capacitor voltage by 180° .
 - lags the capacitor voltage by 180° .
 - leads the capacitor voltage by 90° .
- The impedance Z of an ac circuit determines:
 - The equivalent reactance X_{EQ} of the circuit.
 - The total opposition to voltage changes of the circuit.
 - The total opposition to current flow of the circuit.
 - All of the above.

7. Given a series ac circuit containing an inductor ($X_L = 250 \Omega$) and a capacitor ($X_C = 150 \Omega$), calculate the equivalent reactance $X_{Equi.}$ of the circuit.
- $X_{Equi.} = -100 \Omega$
 - $X_{Equi.} = 400 \Omega$
 - $X_{Equi.} = 100 \Omega$
 - $X_{Equi.} = -400 \Omega$
8. In an ac circuit containing an ideal inductor, the phasor of the inductor current:
- leads the phasor of inductive reactance by 90° .
 - lags the phasor of inductive reactance by 180° .
 - lags the phasor of inductive reactance by 90° .
 - leads the phasor of inductive reactance by 180° .
9. Given a series ac circuit containing a resistor ($R = 400 \Omega$) and a capacitor ($X_C = 250 \Omega$), calculate the impedance Z of the circuit.
- $Z = 150 \Omega$
 - $Z = 316 \Omega$
 - $Z = 650 \Omega$
 - $Z = 472 \Omega$
10. Which equation determines the reactance X_L of an inductor?
- $X_L = E/2\pi L$
 - $X_L = 2\pi fL$
 - $X_L = 1/2\pi fL$
 - $X_L = \sqrt{R^2 + L^2}$

Power in AC Circuits

UNIT OBJECTIVE

When you have completed this unit, you will know what active, reactive, and apparent power are and how to calculate their value. You will be familiar with phasor diagrams related to the active, reactive, and apparent power in a circuit. You will be able to calculate the total reactive power in a circuit containing more than one reactive element. You will know what the power factor of a circuit is and how to calculate its value. You will also be able to draw the power triangle of a circuit.

DISCUSSION OUTLINE

The Discussion of Fundamentals covers the following points:

- Introduction to active, reactive, and apparent power

DISCUSSION OF FUNDAMENTALS

Introduction to active, reactive, and apparent power

In Exercise 1-3, you saw that the voltage and current waveforms related to a resistor are in phase. You also saw that the waveform of the power dissipated in a resistor has a frequency that is twice the source frequency and is always positive, the mean value of this power waveform corresponding to the amount of power dissipated in the resistor. You will see later in this unit that the power dissipated in resistors is referred to as **active power**.

In Unit 2, you saw that there is a phase shift of 90° between the voltage and current waveforms related to a reactive component. You will see later in this unit that the waveform of the power related to a reactive component also has a frequency of twice the source frequency but has a null average value, meaning that power is not dissipated in the reactive component but simply exchanged with the source. You will see that the power related to reactive components is referred to as **reactive power**. Finally, you will learn that vectorial summation of the active power and reactive power in a circuit allows the **apparent power** in the circuit to be determined. You will see in Unit 4 that calculating the active, reactive, and apparent power in a circuit (i.e., determining the **power triangle** of the circuit) is often necessary to solve complex ac circuits.

Active and Reactive Power

EXERCISE OBJECTIVE When you have completed this exercise, you will know what active power and reactive power are. You will also know how to calculate active power and reactive power in the components of an ac circuit.

DISCUSSION OUTLINE The Discussion of this exercise covers the following points:

- Active power in a resistor
- Reactive power in an inductor
- Reactive power in a capacitor
- Power Meter

DISCUSSION

Active power in a resistor

Figure 3-1 displays the voltage, current, instantaneous power, and average power related to a resistor.

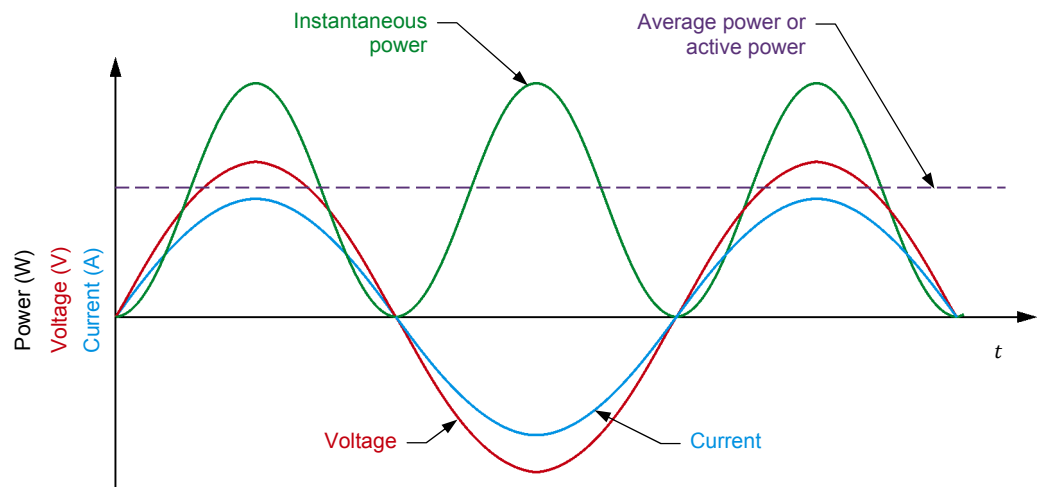

Figure 3-1. Voltage, current, instantaneous power, and average power related to a resistor.

Figure 3-1 shows that the power waveform related to a resistor never changes polarity, i.e., it is always positive. This indicates that the resistor receives power from the ac power source and uses all this power to produce heat. In other words, the resistor receives power from the source without returning any power to the source.

The power used by a resistor to produce heat is referred to as the active power P (expressed in watts [W]) because it is used to perform work (the production of heat is a form of work). The amount of active power P dissipated in

a resistor is equal to the average value of the power waveform and can be determined from the rms values of the voltage across the resistor and the current flowing in the resistor. The equation for calculating the active power dissipated in a resistor is given below:

$$P = E_R \times I_R \tag{3-1}$$

where P is the active power dissipated in the resistor, expressed in watts (W).

E_R is the rms value of the voltage across the resistor, expressed in volts (V).

I_R is the rms value of the current flowing in the resistor, expressed in amperes (A).

Reactive power in an inductor

Figure 3-2 displays the voltage, current, instantaneous power, and average power related to an inductor.

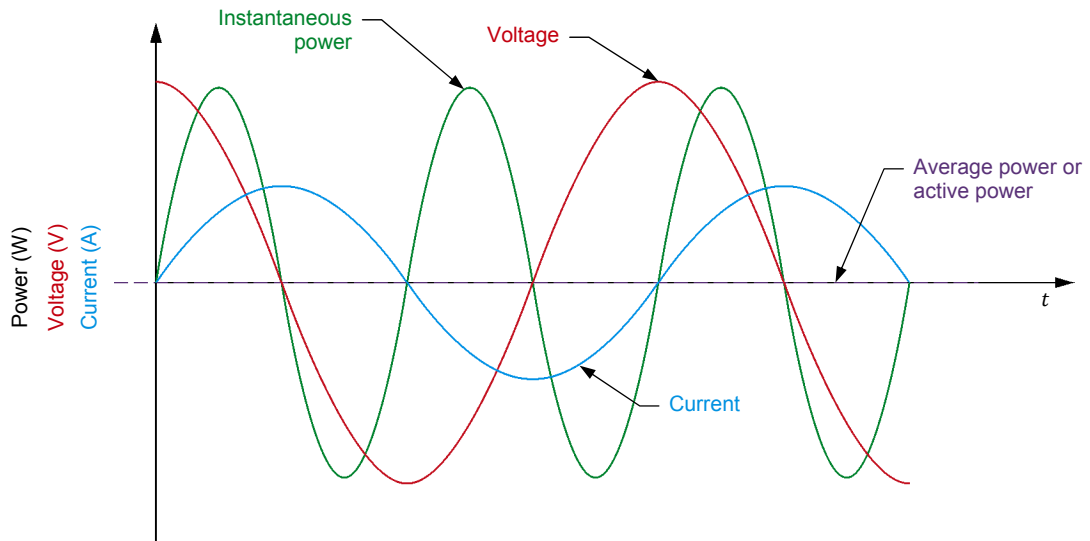

Figure 3-2. Voltage, current, instantaneous power, and average power related to an inductor.

Figure 3-2 shows that the power waveform related to an inductor is a sine wave having twice the frequency of the ac power source, which is similar to the power waveform related to a resistor. However, the polarity of the power waveform related to an inductor alternates, i.e., it is positive half of the time and negative the other half of the time. When the polarity of the power waveform is positive, the source delivers power to the inductor. Conversely, when the polarity of the power waveform is negative, it is the inductor that delivers power to the source, i.e., the inductor returns the received power to the source. Therefore, no power is dissipated in an ideal inductor and no work is done. In other words, the active power in an ideal inductor is null. This is confirmed by the fact that the average value of the power waveform related to an inductor (see Figure 3-2) is equal to 0.

The power in an inductor is referred to as the reactive power Q_L (expressed in reactive volt-amperes [var]) because this power is not used to perform work. Reactive power simply indicates that power is exchanged between the source and the inductor.

Like the active power P dissipated in a resistor, the reactive power Q_L in an inductor can be determined from the rms values of the voltage across the inductor and the current flowing in the inductor. The equation for calculating the reactive power Q_L in an inductor is given below:

$$Q_L = E_L \times I_L \quad (3-2)$$

where Q_L is the reactive power in the inductor, expressed in reactive volt-amperes (var).

E_L is the rms value of the voltage across the inductor, expressed in volts (V).

I_L is the rms value of the current flowing in the inductor, expressed in amperes (A).

This relationship is true only for ideal inductors. In actual inductors, a small amount of active power is dissipated in the wire of the inductor coil and thus, not returned to the source. Because of this, the measured amount of reactive power in an actual inductor is slightly lower than the value of the reactive power Q_L in the inductor calculated using Equation (3-2).

Reactive power in a capacitor

Figure 3-3 displays the voltage, current, instantaneous power, and average power related to a capacitor.

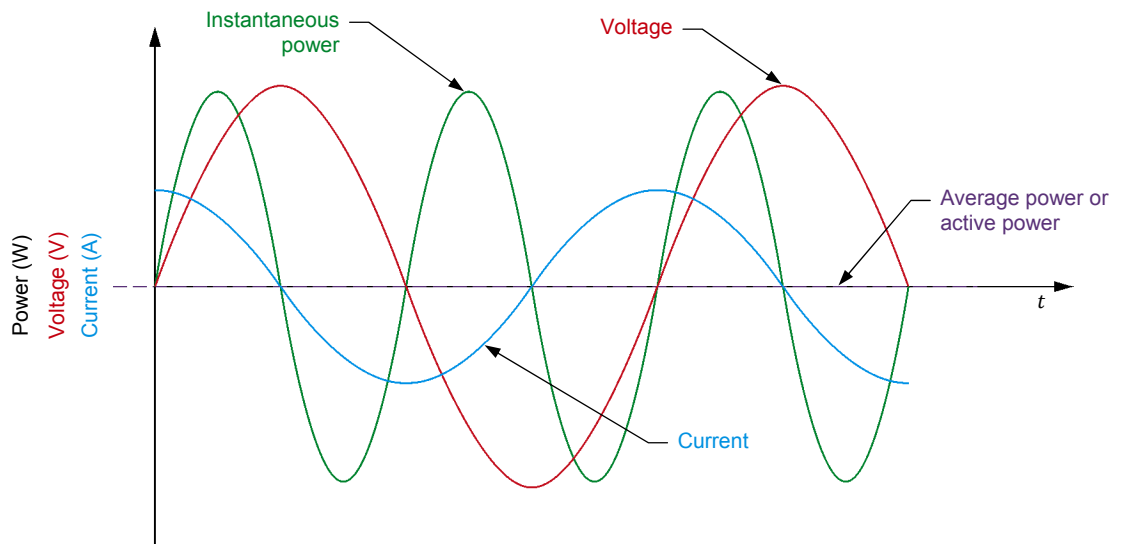

Figure 3-3. Voltage, current, instantaneous power, and average power related to a capacitor.

Figure 3-3 shows that the power waveform related to a capacitor is very similar to the power waveform related to an inductor. Therefore, all observations about the power in an inductor also apply to the power in a capacitor. The equation for calculating the reactive power Q_C in a capacitor is given below:

$$Q_C = E_C \times I_C \quad (3-3)$$

where Q_C is the reactive power in the capacitor, expressed in reactive volt-amperes (var).

E_C is the rms value of the voltage across the capacitor, expressed in volts (V).

I_C is the rms value of the current flowing in the capacitor, expressed in amperes (A).

Power Meter

Commercial instruments are available to measure active power and reactive power directly. These instruments are referred to as power meters. A selector on the power meter usually allows the unit to measure active or reactive power. A power meter determines power by measuring the voltage across a component and the current flowing in the component. All power meters thus generally have at least a voltage input and a current input to measure the circuit voltage and current. Figure 3-4 shows the typical connections of a power meter.

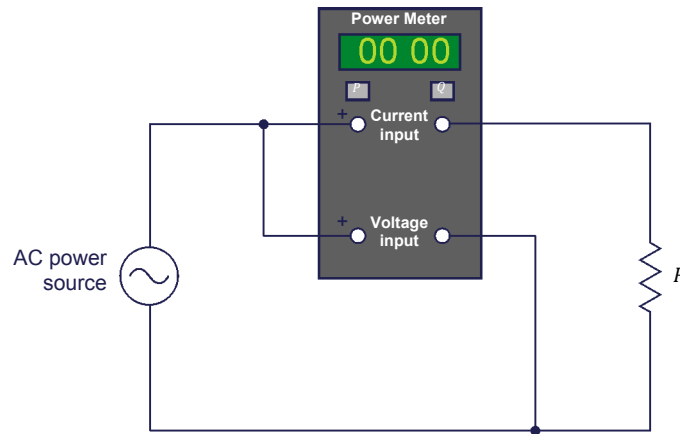

Figure 3-4. AC circuit diagram showing the connections of a power meter.

PROCEDURE OUTLINE

The Procedure is divided into the following sections:

- Setup and connections
- Active power in a resistor
- Reactive power in an inductor
- Reactive power in a capacitor

PROCEDURE



High voltages are present in this laboratory exercise. Do not make or modify any banana jack connections with the power on unless otherwise specified.

Setup and connections

In this section, you will connect an ac circuit containing a resistor and set up the equipment to measure the voltage E_R across the resistor and the current I_R flowing in the resistor.

1. Refer to the Equipment Utilization Chart in Appendix A to obtain the list of equipment required to perform this exercise.

Install the required equipment in the [Workstation](#).

2. Make sure that the main power switch on the [Four-Quadrant Dynamometer/Power Supply](#) is set to the **O** (off) position, then connect its *Power Input* to an ac power outlet.

Connect the *Power Input* of the [Data Acquisition and Control Interface](#) to a 24 V ac power supply. Turn the 24 V ac power supply on.

3. Connect the USB port of the [Data Acquisition and Control Interface](#) to a USB port of the host computer.

Connect the USB port of the [Four-Quadrant Dynamometer/Power Supply](#) to a USB port of the host computer.

4. Turn the [Four-Quadrant Dynamometer/Power Supply](#) on, then set the *Operating Mode* switch to *Power Supply*.

5. Turn the host computer on, then start the LVDAC-EMS software.

In the LVDAC-EMS Start-Up window, make sure that the **Data Acquisition and Control Interface** and the **Four-Quadrant Dynamometer/Power Supply** are detected. Make sure that the **Computer-Based Instrumentation** function for the **Data Acquisition and Control Interface** is available. Select the network voltage and frequency that correspond to the voltage and frequency of your local ac power network, then click the **OK** button to close the LVDAC-EMS Start-Up window.

6. Set up the circuit shown in Figure 3-5.

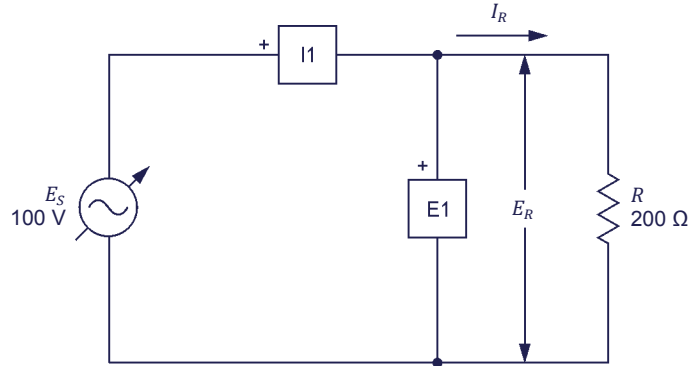

Figure 3-5. AC circuit containing a resistor and set up for power measurements.

Make the necessary switch settings on the **Resistive Load** in order to obtain the resistance value required.

Use inputs **E1** and **I1** of the **Data Acquisition and Control Interface** to measure the resistor voltage E_R and current I_R , respectively.

7. In LVDAC-EMS, open the **Four-Quadrant Dynamometer/Power Supply** window, then make the following settings:
 - Set the **Function** parameter to **AC Power Source**.
 - Make sure that the **Voltage Control** parameter is set to **Knob**. This allows the ac power source to be controlled manually.
 - Set the **No Load Voltage** parameter to 100 V.
 - Set the **Frequency** parameter to the frequency of your local ac power network.
 - Leave the other parameters set as they are.

Active power in a resistor

*In this section, you will calculate the active power P dissipated in the resistor. Using the **Oscilloscope**, you will observe the waveforms of the resistor voltage, current, and power. You will record the average value of the power waveform and compare it with the calculated active power P . You will also determine the active power P in the resistor from the rms values of the resistor voltage E_R and current I_R measured on the **Oscilloscope** and in the **Metering** window, and compare the result with the calculated active power P . Finally, you will measure the reactive power in the resistor to verify that there is virtually no reactive power in a resistor.*

- Calculate the active power P dissipated in the resistor of the circuit shown in Figure 3-5.

Active power $P = \underline{\hspace{2cm}}$ W

- In **LVDAC-EMS**, open the **Metering** window. Set meters **E1** and **I1** to measure the rms values of the resistor voltage E_R (**E1**) and current I_R (**I1**), respectively.

In the **Four-Quadrant Dynamometer/Power Supply** window, enable the ac power source. Readjust the value of the **No Load Voltage** parameter so that the ac power source voltage E_S (indicated by meter **E1** in the **Metering** window) is equal to 100 V.

- In **LVDAC-EMS**, open the **Oscilloscope** and display the resistor voltage, current, and power on channels 1, 2, and 3, respectively. If necessary, set the time base to display at least two cycles of the sine waves.

- Observe the power waveform displayed on the **Oscilloscope**. Is the polarity of the power waveform always positive? Explain why.

- Record the average value of the power waveform indicated on the **Oscilloscope**.

Average power $P_{Avg.} = \underline{\hspace{2cm}}$ W

- Compare the average power $P_{Avg.}$ obtained in the previous step with the calculated active power P recorded in step 8. Are both values close to each other?

Yes No

14. Record the rms values of the resistor voltage E_R and current I_R indicated on the Oscilloscope.

Resistor voltage $E_R =$ _____ V Resistor current $I_R =$ _____ A

15. Calculate the active power P dissipated in the resistor from the rms values of the resistor voltage E_R and current I_R measured in the previous step.

Active power $P =$ _____ W

16. Compare the active power P obtained in the previous step with the calculated active power P recorded in step 8. Are both values close to each other?

Yes No

17. In the Metering window, set a meter to measure the active power P in the resistor from the rms values of the resistor voltage E_R (input $E1$) and current I_R (input $I1$). Record the active power P indicated by the meter below.

Active power $P =$ _____ W

18. Compare the active power P obtained in the previous step with the calculated active power P recorded in step 8. Are both values close to each other?

Yes No

19. In the Metering window, set a meter to measure the reactive power Q in the resistor from the rms values of the resistor voltage E_R and current I_R . Record the reactive power Q indicated by the meter below.

Reactive power $Q =$ _____ var

20. Do the values of the reactive power Q obtained in the previous step and the active power P recorded in step 17 confirm that virtually all the power supplied to a resistor is dissipated in the resistor and does not return to the source (i.e., that there is only active power in a resistor)?

Yes No

Reactive power in an inductor

In this section, you will set up an ac circuit containing an inductor. You will calculate the reactive power Q_L in the inductor. Using the Oscilloscope, you will observe the waveforms of the inductor voltage, current, and power, and confirm that the power waveform has a virtually null average value. You will determine the reactive power Q_L in the inductor from the rms values of the inductor voltage E_L and current I_L measured on the Oscilloscope and in the Metering window, and compare the result with the calculated reactive power Q_L . Finally, you will measure the active power P in the inductor to verify that the active power in an inductor has a virtually null value.

21. In the **Four-Quadrant Dynamometer/Power Supply** window, disable the ac power source.

22. Set up the circuit shown in Figure 3-6.

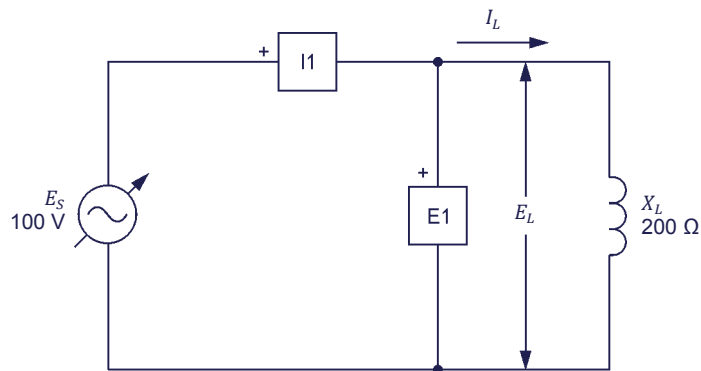

Figure 3-6. AC circuit containing an inductor and set up for power measurements.

Make the necessary switch settings on the **Inductive Load** (or on the **Inductive and Capacitive Loads**) in order to obtain the inductive reactance value required.

Use inputs **E1** and **I1** of the **Data Acquisition and Control Interface** to measure the voltage E_L across the inductor and current I_L flowing through the inductor, respectively.

23. Calculate the reactive power Q_L in the inductor.

Reactive power $Q_L = \underline{\hspace{2cm}}$ var

24. In the **Four-Quadrant Dynamometer/Power Supply** window, enable the ac power source.

In the **Four-Quadrant Dynamometer/Power Supply** window, readjust the value of the **No Load Voltage** parameter so that the ac power source voltage E_S (indicated by meter **E1** in the **Metering** window) is equal to 100 V.

25. Observe the inductor power waveform displayed on the [Oscilloscope](#). Is the polarity of the power waveform alternating? Explain why.

26. Has the inductor power waveform a virtually null average value? Explain why.

27. Record the rms values of the inductor voltage E_L and current I_L indicated on the [Oscilloscope](#).

Inductor voltage $E_L =$ _____ V Inductor current $I_L =$ _____ A

28. Calculate the reactive power Q_L in the inductor from the rms values of the inductor voltage E_L and current I_L measured in the previous step.

Reactive power $Q_L =$ _____ var

29. Compare the reactive power Q_L obtained in the previous step with the calculated reactive power Q_L recorded in step 23. Are both values close to each other?

Yes No

30. In the [Metering](#) window, set a meter to measure the active power P in the inductor from the rms values of the inductor voltage E_L (input $E1$) and current I_L (input $I1$). Record the active power P indicated by the meter.

Active power $P =$ _____ W

31. In the [Metering](#) window, set a meter to measure the reactive power Q_L in the inductor from the rms values of the inductor voltage E_L and current I_L . Record the reactive power Q_L indicated by the meter.

Reactive power $Q_L =$ _____ var

32. Do the values of the reactive power Q_L obtained in the previous step and the active power P recorded in step 30 confirm that virtually all the power supplied to an inductor is returned to the source and that very little power is dissipated in the inductor (i.e., that there is mainly reactive power in an inductor)?

Yes No

Reactive power in a capacitor

In this section, you will set up an ac circuit containing a capacitor. You will calculate the reactive power Q_C in the capacitor. Using the Oscilloscope, you will observe the waveforms of the capacitor voltage, current, and power, and confirm that the average value of the power waveform is null. You will calculate the reactive power Q_C in the capacitor from the rms values of the capacitor voltage E_C and current I_C measured on the Oscilloscope and in the Metering window, and compare the result with the calculated reactive power Q_C . Finally, you will measure the active power P in the capacitor to verify that the active power in a capacitor has a virtually null value.

33. In the **Four-Quadrant Dynamometer/Power Supply** window, disable the ac power source.

34. Set up the circuit shown in Figure 3-7.

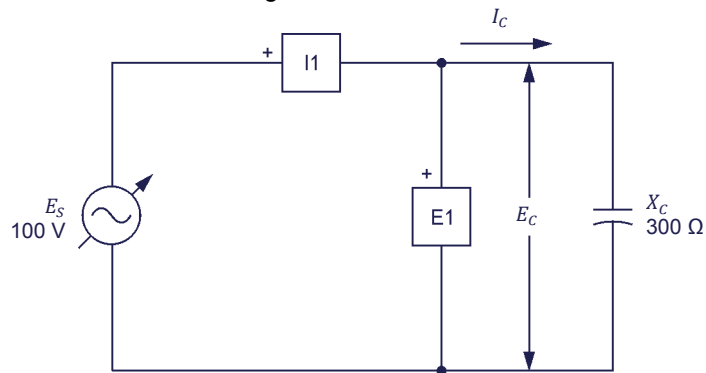

Figure 3-7. AC circuit containing a capacitor and set up for power measurements.

Make the necessary switch settings on the **Capacitive Load** (or on the **Inductive and Capacitive Loads**) in order to obtain the capacitive reactance value required.

Use inputs **E1** and **I1** of the **Data Acquisition and Control Interface** to measure the voltage E_C across the capacitor and current I_C flowing through the capacitor, respectively.

35. Calculate the reactive power Q_C in the capacitor.

Reactive power $Q_C = \underline{\hspace{2cm}}$ var

36. In the **Four-Quadrant Dynamometer/Power Supply** window, enable the ac power source.

In the **Four-Quadrant Dynamometer/Power Supply** window, readjust the value of the **No Load Voltage** parameter so that the ac power source voltage E_s (indicated by meter **E1** in the **Metering** window) is equal to 100 V.

37. Observe the capacitor power waveform displayed on the **Oscilloscope**. Is the polarity of the power waveform alternating?

Yes No

38. Is the average value of the capacitor power waveform null? Explain why?

39. Record the rms values of the capacitor voltage E_C and current I_C indicated on the **Oscilloscope**.

Capacitor voltage $E_C =$ _____ V

Capacitor current $I_C =$ _____ A

40. Calculate the reactive power Q_C in the capacitor from the rms values of the capacitor voltage E_C and current I_C measured in the previous step.

Reactive power $Q_C =$ _____ var

41. Compare the reactive power Q_C obtained in the previous step with the calculated reactive power Q_C recorded in step 35. Are both values close to each other?

Yes No

42. In the **Metering** window, set a meter to measure the active power P in the capacitor from the rms values of the capacitor voltage E_C (input **E1**) and current I_C (input **I1**). Record the active power P indicated by the meter.

Active power $P =$ _____ W

43. In the **Metering** window, set a meter to measure the reactive power Q_C in the capacitor from the rms values of the capacitor voltage E_C and current I_C . Record the reactive power Q_C indicated by the meter.

Reactive power $Q_C = \underline{\hspace{2cm}}$ var

44. Do the values of the reactive power Q_C obtained in the previous step and the active power P recorded in step 42 confirm that virtually all the power supplied to a capacitor is returned to the source and that very little power is dissipated in the capacitor (i.e., that there is only reactive power in a capacitor)?

Yes No

45. In the **Four-Quadrant Dynamometer/Power Supply** window, disable the ac power source.

46. Close **LVDAC-EMS**, then turn off all the equipment. Disconnect all leads and return them to their storage location.

CONCLUSION

In this exercise, you learned what active power and reactive power are. You also learned how to calculate the active and reactive power in the components of an ac circuit.

REVIEW QUESTIONS

1. What is the main difference between active and reactive power.

2. What is the difference between the power waveform related to a resistor (active power waveform) and the power waveform (reactive power waveform) related to a reactive component?

3. Consider an ac circuit containing a capacitor ($X_C = 300 \Omega$) and having a source voltage E_S of 100 V. Calculate the reactive power Q_C in the capacitor.

4. Consider an ac circuit containing an inductor ($X_L = 200 \Omega$). Calculate the source voltage E_S , knowing that the reactive power Q_L in the inductor is equal to 70 var.

5. Consider an ac circuit containing a resistor and having a source voltage E_S of 100 V. Calculate the resistance R of the resistor, knowing that the active power P dissipated in the resistor is equal to 75 W.

Apparent Power and the Power Triangle

EXERCISE OBJECTIVE When you have completed this exercise, you will be familiar with phasor diagrams showing the active power, reactive power, and apparent power in a circuit. You will know what the power factor of a circuit is and how to calculate its value. You will also know how to calculate the total reactive power and the apparent power in a circuit. You will be able to represent the active, reactive, and apparent power in a circuit as a power triangle.

DISCUSSION OUTLINE The Discussion of this exercise covers the following points:

- Phasor diagrams related to active and reactive power
- Apparent power
- Power triangle
- Power factor

DISCUSSION

Phasor diagrams related to active and reactive power

Phasor diagram related to the active power in a resistor

When a resistor is connected to an ac power source, the current flowing in the resistor is in phase with the voltage across the resistor (see Figure 3-8). The active power P dissipated in the resistor can be determined using vectorial calculation to solve the equation $P = E_R \angle 0^\circ \times I_R \angle 0^\circ$. The result of this calculation is a phasor having twice the frequency of the ac power source and a phase angle of 0° as shown in the figure below.

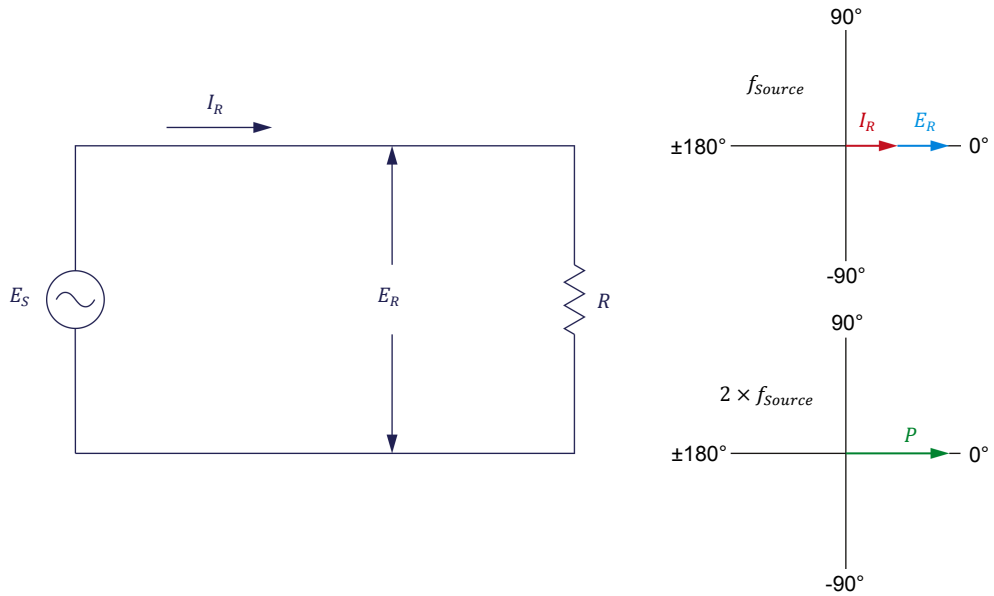

Figure 3-8. AC circuit containing a resistor and corresponding phasor diagrams showing the resistor voltage E_R , current I_R , and active power P .

Phasor diagram related to the reactive power in an inductor

When an ideal inductor is connected to an ac power source, the current flowing in the inductor lags the voltage across the inductor by 90° (see Figure 3-9). The reactive power Q_L in the inductor can be determined using vectorial calculation to solve the equation $Q_L = E_L \angle 0^\circ \times I_L \angle -90$. The result of this calculation is a phasor having twice the frequency of the ac power source and a phase of -90° as shown in the figure below.

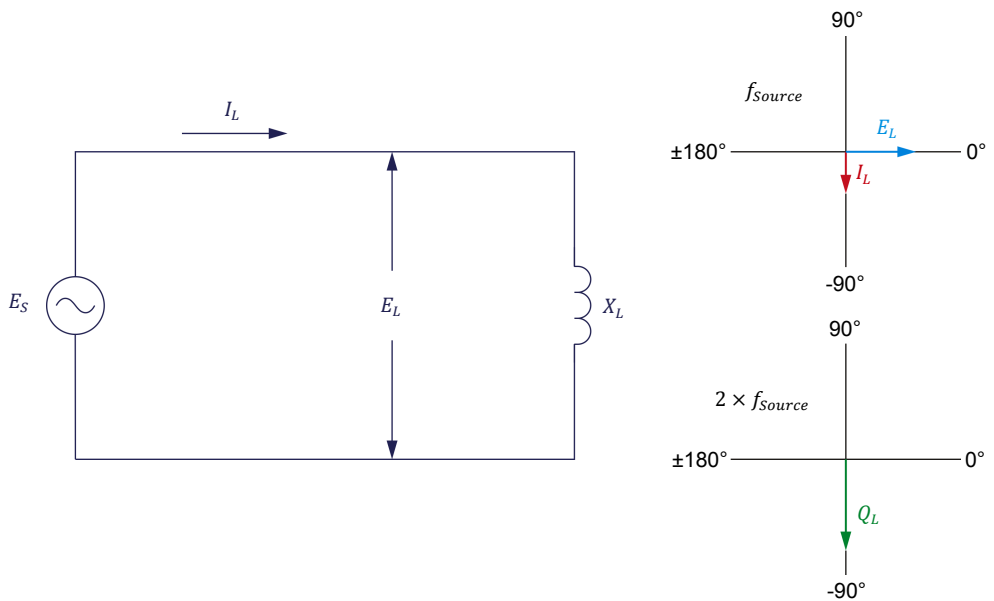

Figure 3-9. AC circuit containing an inductor and corresponding phasor diagrams showing the inductor voltage E_L , current I_L , and reactive power Q_L .

Phasor diagram related to the reactive power in a capacitor

Similarly, when a capacitor is connected to an ac power source, the current flowing in the capacitor leads the voltage across the capacitor by 90° (see Figure 3-10). As for inductors, the reactive power Q_C in a capacitor can be determined using vectorial calculation to solve the equation $Q_C = E_C \angle 0^\circ \times I_C \angle 90^\circ$. The result of the calculation is a phasor having twice the frequency of the ac power source and a phase angle of 90° as shown in the figure below.

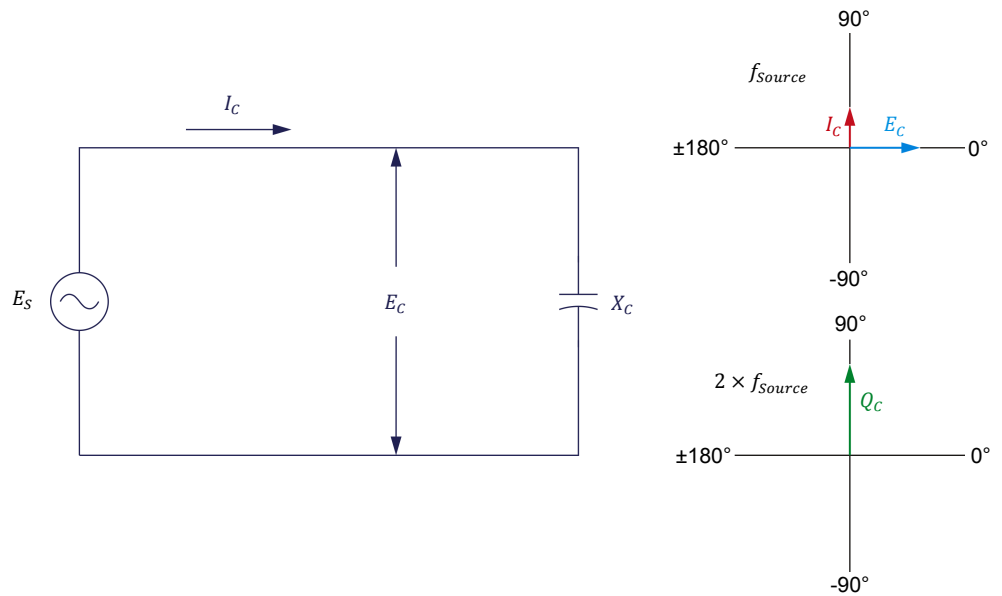

Figure 3-10. AC circuit containing a capacitor and corresponding phasor diagrams showing the capacitor voltage E_C , current I_C , and reactive power Q_C .

Comparing Figure 3-9 and Figure 3-10 shows that the phasor of the reactive power Q_L in an inductor is 180° out of phase with respect to the phasor of the reactive power Q_C in a capacitor. Therefore, when an inductor and a capacitor are both present in an ac circuit, the total reactive power Q in the circuit is equal to $Q_L - Q_C$. This relationship is valid whether the reactive components are connected in series or in parallel. The total reactive power Q is in fact the reactive power that the source exchanges with the inductor and capacitor. When Q_L has a higher value than Q_C , the total reactive power Q is positive. Conversely, when Q_C has a higher value than Q_L , the total reactive power Q is negative. Figure 3-11 shows an example of the total reactive power Q when the reactive power Q_L exceeds the reactive power Q_C in an ac circuit containing an inductor and a capacitor.

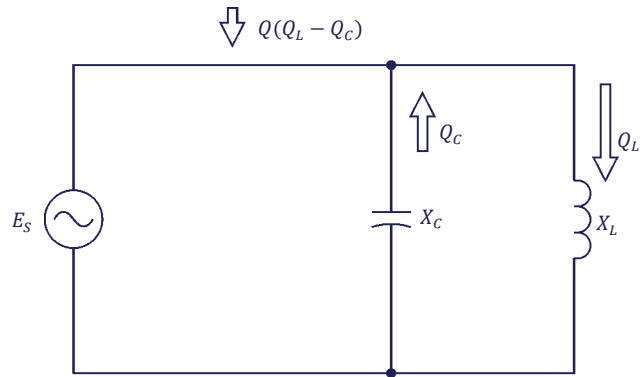

Figure 3-11. Total reactive power Q in an ac circuit containing an inductor and a capacitor ($Q_L > Q_C$).

Apparent power

When an ac power source is connected to a circuit containing a resistor and reactive components, the source delivers active power P to the resistor and exchanges reactive power Q with the reactive components. This is illustrated in Figure 3-12.

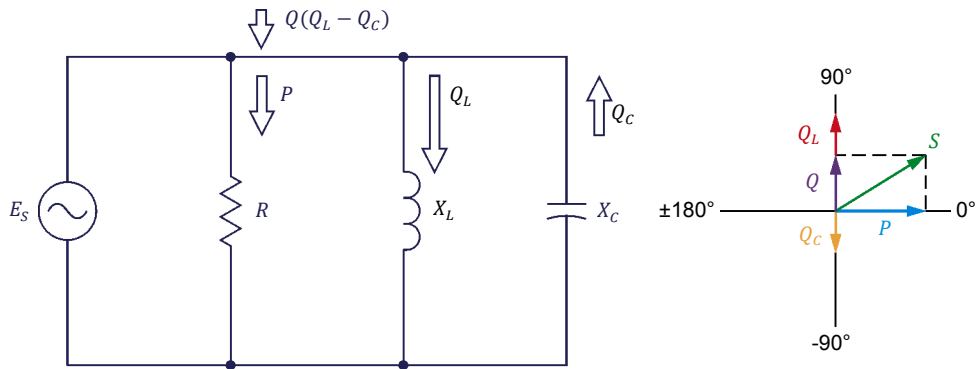

Figure 3-12. AC circuit containing a resistor, an inductor, and a capacitor, and corresponding phasor diagram showing the active, reactive, and apparent power in the circuit.

The phasor diagram in Figure 3-12 shows that the apparent power S , which corresponds to the total power in an ac circuit, is equal to the vectorial sum of the active power P in the resistor and the total reactive power Q in the reactive components. Therefore, following the Pythagorean theorem, the apparent power S in a circuit can be calculated using the following equation:

$$S = \sqrt{P^2 + Q^2} \quad (3-4)$$

where S is the apparent power or total power in the circuit, expressed in volt-amperes (VA).

P is the total active power dissipated in the circuit, expressed in watts (W).

Q is the total reactive power in the circuit, expressed in reactive volt-amperes (var).

Equation (3-4) is valid for parallel circuits (as in Figure 3-12), series circuits, and series-parallel circuits. The apparent power S in an ac circuit can also be determined by multiplying the rms values of the source voltage E_S and current I_S , as shown in the following equation:

$$S = E_S \times I_S \quad (3-5)$$

Power triangle

The phasors representing the active power P , the reactive power Q , and the apparent power S in an ac circuit form a triangle. This triangle is known as the power triangle. An example of a power triangle is given in Figure 3-13.

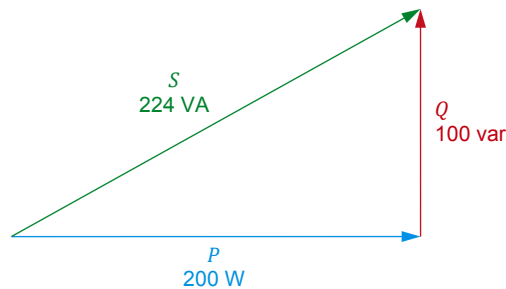

Figure 3-13. Power triangle.

Power factor

When analyzing a circuit, it is often important to know what portion of the current flowing in the circuit is used to perform actual work (i.e., to carry active power) and what portion of the current flowing in the circuit is simply used for the exchange of power between the reactive components and the source. These portions can be evaluated by determining the **power factor** of the circuit.

The power factor PF of a circuit is the ratio of the active power P to the apparent power S in the circuit. It can thus be determined using the following equation:

$$PF = P/S \quad (3-6)$$

where PF is the power factor of the circuit.

The power factor is a ratio between two terms expressed in units of power (1 W = 1 VA). Therefore, it is a dimensionless quantity.

The power factor PF of a circuit can vary between 0 (purely reactive circuit) and 1 (purely resistive circuit). The higher the value of the power factor, the more efficient a circuit is in using electrical power to do useful work (heating, propelling a vehicle, etc.). This means that, for the same amount of active power supplied to a load, a circuit having a low power factor will draw more current (more reactive power will be exchanged in the circuit) than a circuit having a high power factor. An electric power system having a low power factor requires larger wires and loses more energy in the distribution system to perform the same amount of work as an electric power system having a high power factor.

PROCEDURE OUTLINE

The Procedure is divided into the following sections:

- Setup and connections
- Total reactive power in a circuit
- Apparent power, power factor, and power triangle

PROCEDURE



High voltages are present in this laboratory exercise. Do not make or modify any banana jack connections with the power on unless otherwise specified.

Setup and connections

In this section, you will connect a parallel ac circuit containing an inductor and a capacitor, and set up the equipment to measure the voltages and currents related to these components.

1. Refer to the Equipment Utilization Chart in Appendix A to obtain the list of equipment required to perform this exercise.

Install the required equipment in the [Workstation](#).

2. Make sure that the main power switch on the [Four-Quadrant Dynamometer/Power Supply](#) is set to the **O** (off) position, then connect its *Power Input* to an ac power outlet.

Connect the *Power Input* of the [Data Acquisition and Control Interface](#) to a 24 V ac power supply. Turn the 24 V ac power supply on.

3. Connect the USB port of the [Data Acquisition and Control Interface](#) to a USB port of the host computer.

Connect the USB port of the [Four-Quadrant Dynamometer/Power Supply](#) to a USB port of the host computer.

4. Turn the [Four-Quadrant Dynamometer/Power Supply](#) on, then set the *Operating Mode* switch to *Power Supply*.
5. Turn the host computer on, then start the [LVDAC-EMS](#) software.

In the [LVDAC-EMS Start-Up](#) window, make sure that the [Data Acquisition and Control Interface](#) and the [Four-Quadrant Dynamometer/Power Supply](#) are detected. Make sure that the *Computer-Based Instrumentation* function for the [Data Acquisition and Control Interface](#) is available. Select the network voltage and frequency that correspond to the voltage and frequency of your local ac power network, then click the *OK* button to close the [LVDAC-EMS Start-Up](#) window.

6. Set up the circuit shown in Figure 3-14.

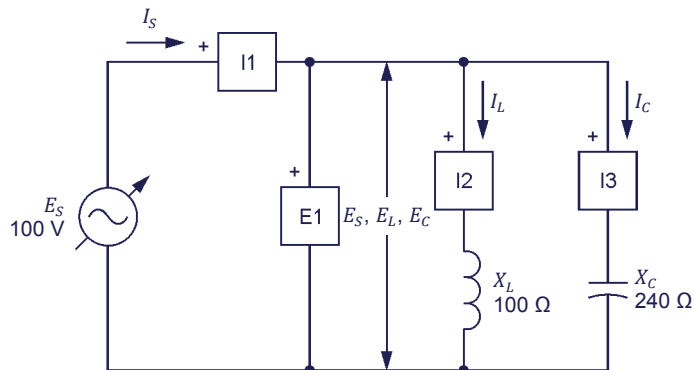

Figure 3-14. Parallel ac circuit containing an inductor and a capacitor, and set up for measuring the reactive power in each component.

Make the necessary switch settings on the [Inductive Load](#) and [Capacitive Load](#) (or on the [Inductive and Capacitive Loads](#)) in order to obtain the inductive reactance and capacitive reactance values required.

Use inputs *E1*, *I1*, *I2*, and *I3* of the [Data Acquisition and Control Interface](#) to measure the source voltage E_S ($E_S = E_L = E_C$), the source current I_S , the inductor current I_L , and the capacitor current I_C , respectively.

7. In LVDAC-EMS, open the Four-Quadrant Dynamometer/Power Supply window, then make the following settings:
 - Set the *Function* parameter to *AC Power Source*.
 - Make sure that the *Voltage Control* parameter is set to *Knob*. This allows the ac power source to be controlled manually.
 - Set the *No Load Voltage* parameter to 100 V.
 - Set the *Frequency* parameter to the frequency of your local ac power network.
 - Leave the other parameters set as they are.

Total reactive power in a circuit

In this section, you will calculate the reactive power Q_L in the inductor, the reactive power Q_C in the capacitor, and the total reactive power Q in the circuit. You will use the Metering window to measure the source voltage E_S , the source current I_S , the inductor current I_L , and the capacitor current I_C . You will then determine from these values the reactive power Q_L in the inductor, reactive power Q_C in the capacitor, and total reactive power Q in the circuit, and compare the results with the calculated values. You will also determine the total reactive power Q from the measured rms values of the source voltage E_S and current I_S , and compare the result with the calculated total reactive power. You will use the Metering window to measure the total reactive power Q directly and compare the result with the calculated total reactive power.

8. Calculate the reactive power Q_L in the inductor, the reactive power Q_C in the capacitor, and the total reactive power Q in the circuit.

Reactive power $Q_L =$ _____ var

Reactive power $Q_C =$ _____ var

Total reactive power $Q =$ _____ var

9. In LVDAC-EMS, open the Metering window. Set meter *E1* to measure the rms value of the ac power source voltage .

In the Four-Quadrant Dynamometer/Power Supply window, enable the ac power source. Readjust the value of the *No Load Voltage* parameter so that the ac power source voltage E_S (indicated by meter *E1* in the Metering window) is equal to 100 V.

10. In the **Metering** window, set meter **E1** to measure the rms value of the source voltage E_S ($E_S = E_L = E_C$) and meters **I1**, **I2**, and **I3** to measure the rms values of the source current I_S , the inductor current I_L , and the capacitor current I_C , respectively. Record the values below.

$$E_S = \underline{\hspace{2cm}} \text{ V} \qquad I_S = \underline{\hspace{2cm}} \text{ A}$$

$$E_L = \underline{\hspace{2cm}} \text{ V} \qquad I_L = \underline{\hspace{2cm}} \text{ A}$$

$$E_C = \underline{\hspace{2cm}} \text{ V} \qquad I_C = \underline{\hspace{2cm}} \text{ A}$$

11. Determine the reactive power Q_L in the inductor, the reactive power Q_C in the capacitor, and the total reactive power Q in the circuit using the voltage and current values measured in the previous step.

$$\text{Reactive power } Q_L = \underline{\hspace{2cm}} \text{ var}$$

$$\text{Reactive power } Q_C = \underline{\hspace{2cm}} \text{ var}$$

$$\text{Total reactive power } Q = \underline{\hspace{2cm}} \text{ var}$$

12. Compare the reactive power Q_L in the inductor, the reactive power Q_C in the capacitor, and the total reactive power Q in the circuit obtained in the previous step with the calculated values you recorded in step 8. Are the values close to each other?

Yes No

13. Determine the total reactive power Q in the circuit using the rms values of the source voltage E_S and current I_S you measured in step 10. Record the result below.

$$\text{Total reactive power } Q = \underline{\hspace{2cm}} \text{ var}$$

14. Compare the total reactive power Q obtained in the previous step with the reactive power values you recorded in steps 8 and 11. Are the values close to each other?

Yes No

15. In the **Metering** window, set a meter to measure the total reactive power Q in the circuit. Record the value below.

$$\text{Total reactive power } Q = \underline{\hspace{2cm}} \text{ var}$$

16. Does the total reactive power Q measured in the previous step confirm the other total reactive power values you obtained so far?

- Yes No

Apparent power, power factor, and power triangle

In this section, you will set up a parallel ac circuit containing a resistor, an inductor, and a capacitor. You will calculate the active power P dissipated in the resistor, the total reactive power Q in the circuit, the apparent power S in the circuit, and the power factor PF of the circuit. Using the Metering window, you will measure the source voltage E_S , the source current I_S , the resistor current I_R , and the current I_X flowing in the inductor and capacitor. You will determine from these measured values the active power P , reactive power Q , and apparent power S in the circuit, and the power factor PF of the circuit. Using the Metering window, you will then measure the active power P , reactive power Q , apparent power S , and power factor PF directly, and compare the results with the values you obtained from the measured voltage and current values. Finally, you will draw the power triangle of the circuit.

17. In the **Four-Quadrant Dynamometer/Power Supply** window, disable the ac power source.

18. Set up the circuit shown in Figure 3-15.

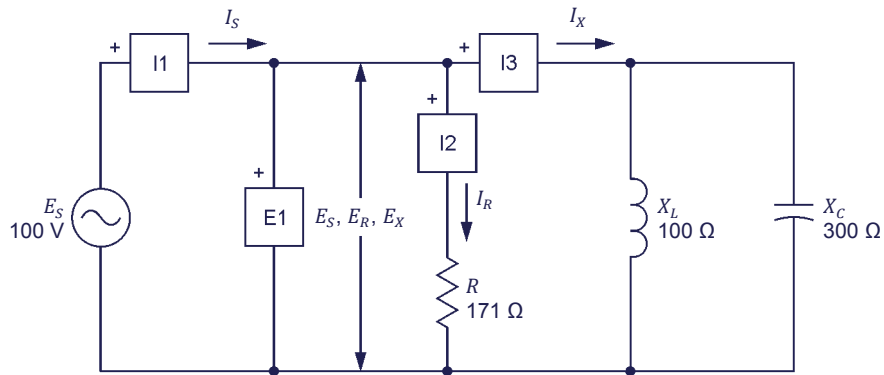

Figure 3-15. Parallel ac circuit containing a resistor, an inductor, and a capacitor, and set up for power measurements.

Make the necessary switch settings on the **Resistive Load**, and on the **Inductive Load** and **Capacitive Load** (or on the **Inductive and Capacitive Loads**) in order to obtain the resistance, inductive reactance, and capacitive reactance values required.

Use inputs **E1**, **I1**, **I2**, and **I3** of the **Data Acquisition and Control Interface** to measure the source voltage E_S and current I_S , the resistor current I_R , and the current I_X flowing through the inductor and capacitor connected in parallel.

19. Calculate the active power P , the total reactive power Q , and the apparent power S in the circuit, and the power factor PF of the circuit. Record the values below.

Active power $P =$ _____ W

Total reactive power $Q =$ _____ var

Apparent power $S =$ _____ VA

Power factor $PF =$ _____

20. In the **Four-Quadrant Dynamometer/Power Supply** window, enable the ac power source. Readjust the value of the **No Load Voltage** parameter so that the source voltage E_S (indicated by meter **E1** in the **Metering** window) is equal to 100 V.

21. In the **Metering** window, measure the rms values of the source voltage E_S ($E_S = E_R = E_X$), the resistor current I_R , and the current I_X . Record the values below.

$E_S =$ _____ V

$E_R =$ _____ V

$I_R =$ _____ A

$E_X =$ _____ V

$I_X =$ _____ A

22. Determine the active power P in the resistor, the total reactive power Q in the circuit, the apparent power S in the circuit, and the power factor PF of the circuit using the voltage and current values measured in the previous step.

Active power $P =$ _____ W

Reactive power $Q =$ _____ var

Apparent power $S =$ _____ VA

Power factor $PF =$ _____

23. Compare the active power P in the resistor, the total reactive power Q in the circuit, the apparent power S in the circuit, and the power factor PF of the circuit obtained in the previous step with the values you calculated in step 19. Are the values close to each other?

Yes No

24. In the **Metering** window, measure the rms value of the source current I_S . Record the value below.

Source current $I_S = \underline{\hspace{2cm}}$ A

25. Determine the apparent power S in the circuit from the measured rms values of the source voltage E_S and current I_S (recorded in step 21 and 24, respectively). Record the result below.

Apparent power $S = \underline{\hspace{2cm}}$ VA

26. Compare the apparent power S obtained in the previous step with the values of the apparent power S recorded in steps 19 and 22. Are all values close to each other?

Yes No

27. In the **Metering** window, set three meters to measure the power in the circuit from the rms values of the source voltage E_S (input **E1**) and current I_S (input **I1**). Set the first meter to measure the active power P , the second meter to measure the total reactive power Q , and the third meter to measure the apparent power S . Set a fourth meter to measure the power factor PF of the circuit. Record the results below.

Active power $P = \underline{\hspace{2cm}}$ W

Total reactive power $Q = \underline{\hspace{2cm}}$ var

Apparent power $S = \underline{\hspace{2cm}}$ VA

Power factor $PF = \underline{\hspace{2cm}}$

28. Do the values of the active power P , total reactive power Q , apparent power S , and power factor PF measured in the previous step confirm the active power, total reactive power, apparent power, and power factor values you obtained so far?

Yes No

29. Draw the power triangle of the circuit using the active power P , total reactive power Q , and apparent power S measured in step 27.

Power triangle of the circuit in Figure 3-15.

30. In the **Four-Quadrant Dynamometer/Power Supply** window, disable the ac power source.

31. Close **LVDAC-EMS**, then turn off all the equipment. Disconnect all leads and return them to their storage location.

CONCLUSION

In this exercise, you became familiar with the phasor diagrams showing the active power, reactive power, and apparent power in a circuit. You learned what the power factor of a circuit is and how to calculate its value. You also learned how to calculate the total reactive power and the apparent power in a circuit. You saw how to represent the active, reactive, and apparent power in a circuit as a power triangle.

REVIEW QUESTIONS

1. Is it possible to determine the phase relationship between a power phasor and the corresponding voltage and current phasors? Explain why.

2. What is the phase relationship between the reactive power in an inductor and the reactive power in a capacitor?

3. What are the differences between the active power P , reactive power Q , and apparent power S ?

4. A parallel ac circuit having a source voltage E_S of 100 V contains an ideal inductor ($X_L = 150 \Omega$) and a capacitor ($X_C = 350 \Omega$). Calculate the resulting total reactive power Q in the circuit. Indicate the phase relationship between the source current I_S and the source voltage E_S .

5. A parallel ac circuit having a source voltage E_S of 150 V contains a resistor ($R = 200 \Omega$) and an inductor ($X_L = 50 \Omega$). Calculate the apparent power S in the circuit and the power factor PF of the circuit.

Unit Test

1. Complete the following sentence: Active power is used by
 - a. resistive components to perform work, while reactive power is exchanged between the source and reactive components without performing any work.
 - b. reactive components to perform work, while reactive power is exchanged between the source and resistive components without performing any work.
 - c. resistive components and is returned to the source without performing any work, while reactive power is exchanged between the source and reactive components to perform work.
 - d. resistive components to perform work and decreases the power factor of the circuit.
2. Which one of the following sentences is true with respect to the waveforms of active power and reactive power?
 - a. The active power waveform has a zero average value and a frequency that is twice the ac power source frequency.
 - b. The reactive power waveform is out of phase with respect to the waveforms of the current and voltage and has a frequency that is equal to the ac power source frequency.
 - c. The reactive power waveform has a positive average value and a frequency that is twice the ac power source frequency.
 - d. The active power waveform has a positive average value and a frequency that is twice the ac power source frequency.
3. Given a parallel ac circuit having a source voltage E_S of 100 V and containing an inductor ($X_L = 150 \Omega$) and a capacitor ($X_C = 300 \Omega$). Calculate the total reactive power Q in the circuit.
 - a. $Q = 100 \text{ var}$
 - b. $Q = 33.4 \text{ var}$
 - c. $Q = -33.4 \text{ var}$
 - d. $Q = 66.6 \text{ var}$
4. Given an ac circuit having a source voltage E_S of 140 V and containing a resistor ($R = 200 \Omega$). Calculate the active power P and reactive power Q in the resistor.
 - a. $P = -98.0 \text{ W}$, $Q = 0.00 \text{ var}$
 - b. $P = 98.0 \text{ W}$, $Q = 98.0 \text{ var}$
 - c. $P = 0.00 \text{ W}$, $Q = 98.0 \text{ var}$
 - d. $P = 98.0 \text{ W}$, $Q = 0.00 \text{ var}$
5. The active power P dissipated in a capacitor is equal to the
 - a. product of the instantaneous values of the capacitor voltage and current.
 - b. instantaneous value of the capacitor power waveform.
 - c. average value of the capacitor power waveform.
 - d. vectorial sum of the reactive and apparent power in the circuit.

6. Complete the following sentence as regards the positive and negative halves of the power waveform related to a reactive component: During the positive half of the power waveform, the reactive component
 - a. absorbs power from the source, while during the negative half of the power waveform, the reactive component returns power to the source.
 - b. transforms power received from the source into active power, while during the negative half of the power waveform, the reactive component converts power in reactive power.
 - c. transforms power received from the source into reactive power, while during the negative half of the power waveform, the reactive component converts power in active power.
 - d. returns power to the source, while during the negative half of the power waveform, the reactive component absorbs power from the source.

7. What is the relationship between the polarity of the total reactive power Q in an ac circuit and the nature of the circuit (inductive or capacitive)?
 - a. An ac circuit having a positive total reactive power Q is capacitive, while an ac circuit having a negative total reactive power Q is inductive.
 - b. An ac circuit having a positive total reactive power Q is inductive, while an ac circuit having a negative total reactive power Q is capacitive.
 - c. An ac circuit having a positive total reactive power Q is both inductive and capacitive, while an ac circuit having a negative total reactive power Q is neither inductive nor capacitive.
 - d. The polarity of the total reactive power Q cannot be used to determine whether an ac circuit is inductive or capacitive.

8. Complete the following sentence: The reactive power Q_L in an ideal inductor
 - a. leads the reactive power Q_C in a capacitor by 180° .
 - b. leads the reactive power Q_C in a capacitor by 90° .
 - c. lags the reactive power Q_C in a capacitor by 180° .
 - d. lags the reactive power Q_C in a capacitor by 90° .

9. The power factor PF of an ac circuit determines the
 - a. frequency of the power waveform.
 - b. ratio between inductive and capacitive reactive power in a circuit.
 - c. ratio between the active power and the apparent power in the circuit.
 - d. ratio between the number of resistive components and the number of reactive components in a circuit.

10. Consider a parallel ac circuit containing a resistor ($R = 100 \Omega$) and an ideal inductor ($X_L = 250 \Omega$). Calculate the apparent power S in the circuit knowing that the active power P in the resistor is equal to 75 W.
 - a. $S = 81.0 \text{ VA}$
 - b. $S = 269 \text{ VA}$
 - c. $S = 150 \text{ VA}$
 - d. $S = 158 \text{ VA}$

AC Circuits Analysis

UNIT OBJECTIVE

When you have completed this unit, you will be able to resolve simple ac circuits using the circuit impedance calculation method. You will also be able to solve complex ac circuits using the power triangle method.

DISCUSSION OUTLINE

The Discussion of Fundamentals covers the following points:

- Introduction to circuit analysis
- Circuit analysis methods

DISCUSSION OF FUNDAMENTALS

Introduction to circuit analysis

Circuit analysis consists of calculating all electrical parameters when a circuit (i.e., an arrangement of electrical components) is connected to an ac power source having a certain voltage E_s . More specifically, circuit analysis consists of determining (via calculations) the voltage across each component, the current flowing in each branch of the circuit, the total circuit current (i.e., the source current I_s), the power in each component, as well as the active power P , the reactive power Q , and the apparent power S in the circuit, and the power factor PF of the circuit.

Circuit analysis methods

Two different methods (approaches) for solving ac circuits are discussed in this unit. The first method relies on the calculation of circuit impedance and can be used to quickly solve simple ac power circuits. The second method is based on the power triangle and can be used to solve almost any ac power circuit. Both of these methods use only simple algebraic calculations and no vectorial calculation whatsoever.

Solving Simple AC Circuits Using Circuit Impedance Calculation

EXERCISE OBJECTIVE When you have completed this exercise, you will be able to resolve simple parallel and series ac circuits using the circuit impedance calculation method.

DISCUSSION OUTLINE The Discussion of this exercise covers the following points:

- Solving simple parallel circuits
- Solving simple series circuits

DISCUSSION **Solving simple parallel circuits**

Figure 4-1 shows a parallel ac circuit containing a resistor and an inductor.

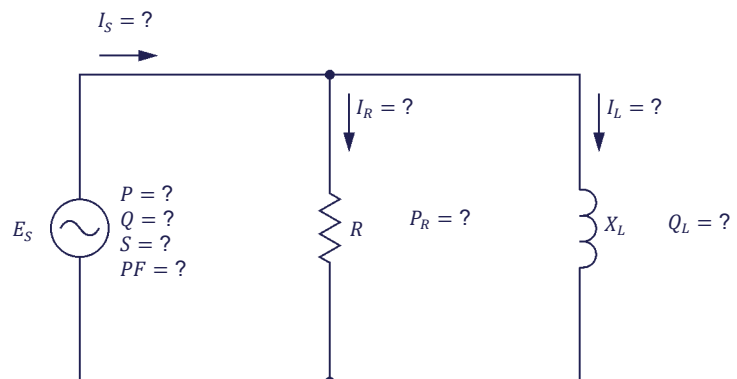

Figure 4-1. Parallel ac circuit containing a resistor and an inductor.

The step-by-step sequence for solving the ac circuit shown in Figure 4-1 using the impedance calculation method is given below. The source voltage E_S , the resistance R of the resistor, and the inductive reactance X_L of the inductor are the only values known in the circuit diagram above. The circuit is solved using the following operations:

$$Z = (R \cdot X_L) / \sqrt{R^2 + X_L^2}$$

$$I_S = E_S / Z$$

$$S = E_S \cdot I_S$$

$$I_R = E_S / R$$

$$P_R = P = E_S \cdot I_R$$

$$I_L = E_S / X_L$$

$$Q_L = Q = E_S \cdot I_L$$

$$PF = P / S$$

As the name of the method indicates, the key to solving the circuit using the circuit impedance calculation method is to determine the circuit impedance Z . When the circuit impedance Z is determined, the other calculations follow logically.

Example

Consider the following ac circuit:

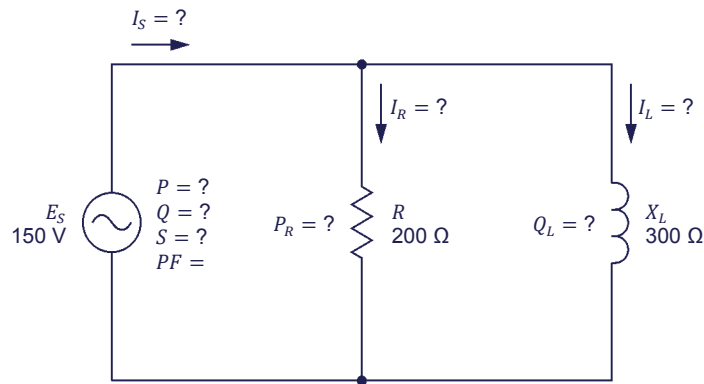

Figure 4-2. Parallel ac circuit containing a resistor and an inductor.

The step-by-step sequence for solving the circuit shown in Figure 4-2 using the impedance calculation method is given below:

$$Z = (R \cdot X_L) / \sqrt{R^2 + X_L^2} = (200 \Omega \cdot 300 \Omega) / \sqrt{(200 \Omega)^2 + (300 \Omega)^2} = 166 \Omega$$

$$I_S = E_S / Z = 150 \text{ V} / 166 \Omega = 0.90 \text{ A}$$

$$S = E_S \cdot I_S = 150 \text{ V} \cdot 0.90 \text{ A} = 135 \text{ VA}$$

$$I_R = E_S / R = 150 \text{ V} / 200 \Omega = 0.75 \text{ A}$$

$$P_R = P = E_S \cdot I_R = 150 \text{ V} \cdot 0.75 \text{ A} = 113 \text{ W}$$

$$I_L = E_S / X_L = 150 \text{ V} / 300 \Omega = 0.50 \text{ A}$$

$$Q_L = Q = E_S \cdot I_L = 150 \text{ V} \cdot 0.50 \text{ A} = 75.0 \text{ var}$$

$$PF = P / S = 113 \text{ W} / 135 \text{ VA} = 0.84$$

Solving simple series circuits

Figure 4-3 shows a series ac circuit containing a resistor, an inductor, and a capacitor.

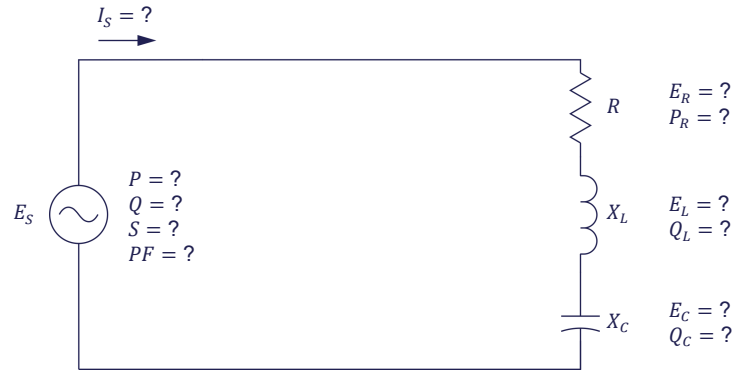

Figure 4-3. Series ac circuit containing a resistor, an inductor, and a capacitor.

The impedance calculation method used to solve parallel ac circuits can also be used to solve the series ac circuit shown in Figure 4-3. Given the values of the source voltage E_S , the resistance R of the resistor, the inductive reactance X_L of the inductor, and the capacitive reactance X_C of the capacitor, the values of the other parameters can be determined as follows:

$$X = X_L - X_C$$

$$Z = \sqrt{R^2 + X^2}$$

$$I_S = E_S / Z$$

$$S = E_S \cdot I_S$$

$$E_R = I_S \cdot R$$

$$P_R = P = E_R \cdot I_S$$

$$E_L = I_S \cdot X_L$$

$$Q_L = I_S \cdot E_L$$

$$E_C = I_S \cdot X_C$$

$$Q_C = I_S \cdot E_C$$

$$Q = Q_L - Q_C$$

$$PF = P / S$$

As with parallel ac circuits, the key to solving the circuit is determining the circuit impedance Z . The rest of the calculations are simple algebraic operations deriving from the value of the circuit impedance Z .

Example

Consider the following ac circuit:



Figure 4-4. Series ac circuit containing a resistor, an inductor, and a capacitor.

The step-by-step sequence for solving the circuit shown in Figure 4-4 using the impedance calculation method is given below.

$$X = X_L - X_C = 300 \Omega - 200 \Omega = 100 \Omega$$

$$Z = \sqrt{R^2 + X^2} = \sqrt{(100 \Omega)^2 + (100 \Omega)^2} = 141 \Omega$$

$$I_S = E_S / Z = 150 \text{ V} / 141 \Omega = 1.06 \text{ A}$$

$$S = E_S \cdot I_S = 150 \text{ V} \cdot 1.06 \text{ A} = 159 \text{ VA}$$

$$E_R = I_S \cdot R = 1.06 \text{ A} \cdot 100 \Omega = 106 \text{ V}$$

$$P_R = P = E_R \cdot I_S = 106 \text{ V} \cdot 1.06 \text{ A} = 112 \text{ W}$$

$$E_L = I_S \cdot X_L = 1.06 \text{ A} \cdot 300 \Omega = 318 \text{ V}$$

$$Q_L = I_S \cdot E_L = 1.06 \text{ A} \cdot 318 \text{ V} = 337 \text{ var}$$

$$E_C = I_S \cdot X_C = 1.06 \text{ A} \cdot 200 \Omega = 212 \text{ V}$$

$$Q_C = I_S \cdot E_C = 1.06 \text{ A} \cdot 212 \text{ V} = 225 \text{ var}$$

$$Q = Q_L - Q_C = 337 \text{ var} - 225 \text{ var} = 112 \text{ var}$$

$$PF = P / S = 112 \text{ W} / 159 \text{ VA} = 0.70$$

As you can see, solving both parallel and series ac circuits using the circuit impedance calculation method involves no vectorial calculation. This method enables the resolution of ac circuits using only basic algebraic calculations.

PROCEDURE OUTLINE

The Procedure is divided into the following sections:

- Setup and connections
- Solving a simple parallel ac circuit
- Solving a simple series ac circuit

PROCEDURE



High voltages are present in this laboratory exercise. Do not make or modify any banana jack connections with the power on unless otherwise specified.

Setup and connections

In this section, you will connect a parallel ac circuit containing a resistor and a capacitor, and set up the equipment to measure all the circuit parameters.

1. Refer to the Equipment Utilization Chart in Appendix A to obtain the list of equipment required to perform this exercise.

Install the required equipment in the [Workstation](#).

2. Make sure that the main power switch on the [Four-Quadrant Dynamometer/Power Supply](#) is set to the **O** (off) position, then connect its [Power Input](#) to an ac power outlet.

Connect the [Power Input](#) of the [Data Acquisition and Control Interface](#) to a 24 V ac power supply. Turn the 24 V ac power supply on.

3. Connect the USB port of the [Data Acquisition and Control Interface](#) to a USB port of the host computer.

Connect the USB port of the [Four-Quadrant Dynamometer/Power Supply](#) to a USB port of the host computer.

4. Turn the [Four-Quadrant Dynamometer/Power Supply](#) on, then set the [Operating Mode](#) switch to [Power Supply](#).

5. Turn the host computer on, then start the [LVDAC-EMS](#) software.

In the [LVDAC-EMS Start-Up](#) window, make sure that the [Data Acquisition and Control Interface](#) and the [Four-Quadrant Dynamometer/Power Supply](#) are detected. Make sure that the [Computer-Based Instrumentation](#) function for the [Data Acquisition and Control Interface](#) is available. Select the network voltage and frequency that correspond to the voltage and frequency of your local ac power network, then click the **OK** button to close the [LVDAC-EMS Start-Up](#) window.

6. Set up the circuit shown in Figure 4-5.

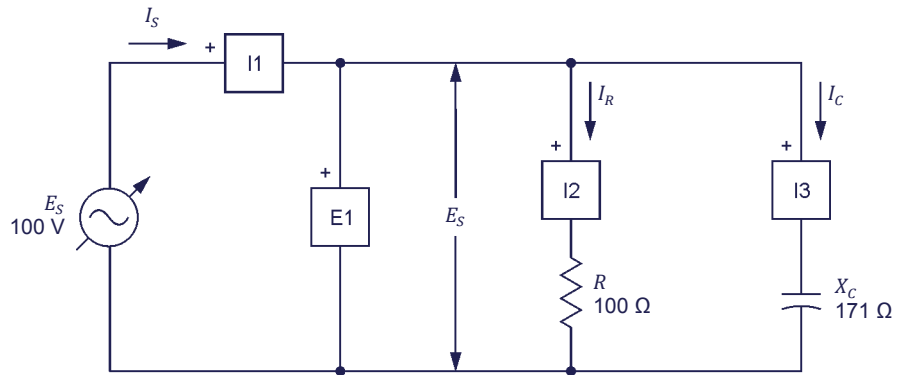

Figure 4-5. Parallel ac circuit containing a resistor and a capacitor, and set up for circuit analysis.

Make the necessary switch settings on the [Resistive Load](#) and [Capacitive Load](#) (or on the [Inductive and Capacitive Loads](#)) in order to obtain the resistance and capacitive reactance values required.

Use inputs *E1*, *I1*, *I2*, and *I3* of the [Data Acquisition and Control Interface](#) to measure the source voltage E_S ($E_S = E_R = E_C$), the source current I_S , the resistor current I_R , and the capacitor current I_C , respectively.

7. In [LVDAC-EMS](#), open the [Four-Quadrant Dynamometer/Power Supply](#) window, then make the following settings:

- Set the *Function* parameter to [AC Power Source](#).
- Make sure that the *Voltage Control* parameter is set to [Knob](#). This allows the ac power source to be controlled manually.
- Set the *No Load Voltage* parameter to 100 V.
- Set the *Frequency* parameter to the frequency of your local ac power network.
- Leave the other parameters set as they are.

Solving a simple parallel ac circuit

In this section, you will use the impedance calculation method to solve the circuit you set up in the previous steps. You will then measure the circuit parameters and compare the results with the calculated circuit parameters.

8. Resolve the entire circuit shown in Figure 4-5 using the impedance calculation method.

Impedance $Z = \underline{\hspace{2cm}} \Omega$

Source current $I_S = \underline{\hspace{2cm}} \text{ A}$

Apparent power $S = \underline{\hspace{2cm}} \text{ VA}$

Resistor current $I_R = \underline{\hspace{2cm}} \text{ A}$

Active power $P_R = P = \underline{\hspace{2cm}} \text{ W}$

Capacitor current $I_C = \underline{\hspace{2cm}} \text{ A}$

Reactive power $Q_C = Q = \underline{\hspace{2cm}} \text{ var}$

Power factor $PF = \underline{\hspace{2cm}}$

9. In **LVDAC-EMS**, open the **Metering** window. Set meter **E1** to measure the rms value of the ac power source voltage E_S .

In the **Four-Quadrant Dynamometer/Power Supply** window, enable the ac power source. Readjust the value of the **No Load Voltage** parameter so that the ac power source voltage E_S (indicated by meter **E1** in the **Metering** window) is equal to 100 V.

10. In the **Metering** window, set the meters to measure the following parameters:

Source voltage $E_S = \underline{\hspace{2cm}} \text{ V}$

Source current $I_S = \underline{\hspace{2cm}} \text{ A}$

Resistor current $I_R = \underline{\hspace{2cm}} \text{ A}$

Capacitor current $I_C = \underline{\hspace{2cm}} \text{ A}$

Active power $P = \underline{\hspace{2cm}} \text{ W}$

Resistor power $P_R = \underline{\hspace{2cm}} \text{ W}$

Reactive power $Q = \underline{\hspace{2cm}} \text{ var}$

Capacitor reactive power $Q_C = \underline{\hspace{2cm}} \text{ var}$

Apparent power $S = \underline{\hspace{2cm}}$ VA

Power factor $PF = \underline{\hspace{2cm}}$

11. Compare the circuit parameters measured in the previous steps with the values you calculated in step 8. Are the values close to each other?
- Yes No

Solving a simple series ac circuit

In this section, you will connect a series ac circuit containing a resistor, an inductor, and a capacitor. You will use the impedance calculation method to solve the circuit. You will then measure the circuit parameters and compare the results with the calculated circuit parameters.

12. In the **Four-Quadrant Dynamometer/Power Supply** window, disable the ac power source.
13. Set up the circuit shown in Figure 4-6.

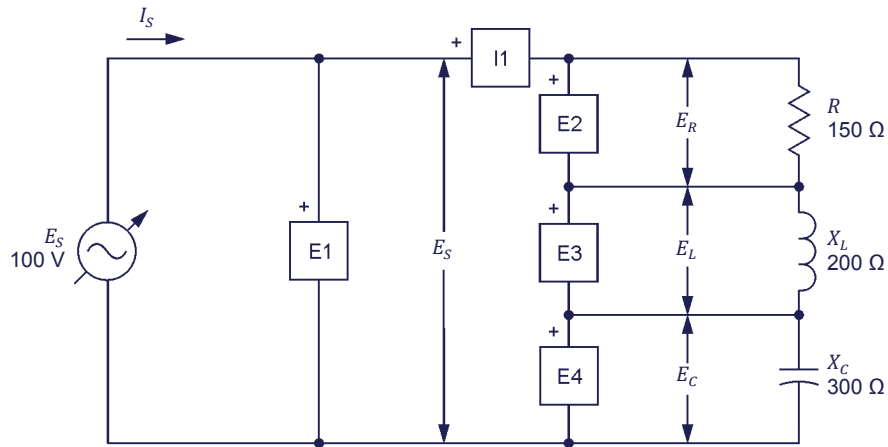

Figure 4-6. Series ac circuit containing a resistor, an inductor, and a capacitor, and set up for circuit analysis.

Make the necessary switch settings on the **Resistive Load**, and on the **Inductive Load** and **Capacitive Load** (or on the **Inductive and Capacitive Loads**) in order to obtain the resistance, inductive reactance, and capacitive reactance values required.

Use inputs **E1**, **E2**, **E3**, **E4**, and **I1** of the **Data Acquisition and Control Interface** to measure the source voltage E_S , the resistor voltage E_R , the inductor voltage E_L , the capacitor voltage E_C , and the source current I_S ($I_S = I_R = I_L = I_C$), respectively.

14. Resolve the entire circuit shown in Figure 4-6 using the impedance calculation method.

Equivalent reactance $X_{EQ} = \underline{\hspace{2cm}} \Omega$

Impedance $Z = \underline{\hspace{2cm}} \Omega$

Source current $I_S = \underline{\hspace{2cm}} \text{ A}$

Apparent power $S = \underline{\hspace{2cm}} \text{ VA}$

Resistor voltage $E_R = \underline{\hspace{2cm}} \text{ V}$

Active power $P_R = P = \underline{\hspace{2cm}} \text{ W}$

Inductor voltage $E_L = \underline{\hspace{2cm}} \text{ V}$

Reactive power $Q_L = \underline{\hspace{2cm}} \text{ var}$

Capacitor voltage $E_C = \underline{\hspace{2cm}} \text{ V}$

Reactive power $Q_C = \underline{\hspace{2cm}} \text{ var}$

Total reactive power $Q = \underline{\hspace{2cm}} \text{ var}$

Power factor $PF = \underline{\hspace{2cm}}$

15. In the **Four-Quadrant Dynamometer/Power Supply** window, enable the ac power source.

Readjust the value of the **No Load Voltage** parameter so that the ac power source voltage E_S (indicated by meter **E1** in the **Metering** window) is equal to 100 V.

16. In the **Metering** window, set the meters to measure the following parameters:

Source voltage $E_S = \underline{\hspace{2cm}} \text{ V}$

Resistor voltage $E_R = \underline{\hspace{2cm}} \text{ V}$

Inductor voltage $E_L = \underline{\hspace{2cm}} \text{ V}$

Capacitor voltage $E_C = \underline{\hspace{2cm}} \text{ V}$

Source current $I_S = \underline{\hspace{2cm}} \text{ A}$

Active power $P = \underline{\hspace{2cm}} \text{ W}$

Resistor power $P_R = \underline{\hspace{2cm}} \text{ W}$

Inductor reactive power $Q_L = \underline{\hspace{2cm}} \text{ var}$

Capacitor reactive power $Q_c =$ _____ var

Total reactive power $Q =$ _____ var

Apparent power $S =$ _____ VA

Power factor $PF =$ _____

17. Compare the circuit parameters measured in the previous steps with the values you calculated in step 14. Are the values close to each other?

Yes No

18. In the **Four-Quadrant Dynamometer/Power Supply** window, disable the ac power source.

19. Close **LVDAC-EMS**, then turn off all the equipment. Disconnect all leads and return them to their storage location.

CONCLUSION

In this exercise, you learned how to resolve simple parallel and series ac circuits using the circuit impedance calculation method.

REVIEW QUESTIONS

1. A parallel ac power circuit contains a resistor ($R = 150 \Omega$) and an inductor ($X_L = 250 \Omega$). Knowing that the source voltage E_S is equal to 150 V, calculate the apparent power S in the circuit using the impedance calculation method.

2. A series ac power circuit contains a resistor ($R = 100 \Omega$) and a capacitor ($X_C = 225 \Omega$). Knowing that the source voltage E_S is equal to 100 V, calculate the power factor PF of the circuit using the impedance calculation method.

3. A parallel ac power circuit contains a resistor ($R = 200 \Omega$), an inductor, and a capacitor. Knowing that the source voltage E_S is equal to 100 V and that the total reactive power Q in the circuit is 70.0 var, calculate the circuit impedance Z .

4. A series ac power circuit contains a resistor ($R = 150 \Omega$), an inductor ($X_L = 250 \Omega$), and a capacitor ($X_C = 200 \Omega$). Knowing that the active power P dissipated in the circuit is equal to 100 W, calculate the apparent power S in the circuit.

5. A series ac power circuit contains a resistor ($R = 250 \Omega$), an inductor ($X_L = 100 \Omega$), and a capacitor ($X_C = 300 \Omega$). Knowing that the source voltage E_S is equal to 150 V, calculate the power factor PF of the circuit.

Solving AC Circuits Using the Power Triangle Method

EXERCISE OBJECTIVE When you have completed this exercise, you will be able to resolve complex ac circuits using the power triangle method.

DISCUSSION OUTLINE The Discussion of this exercise covers the following points:

- Solving ac circuits using the power triangle method

DISCUSSION

Solving ac circuits using the power triangle method

Figure 4-7 shows an ac circuit containing a resistor, an inductor, and two capacitors.

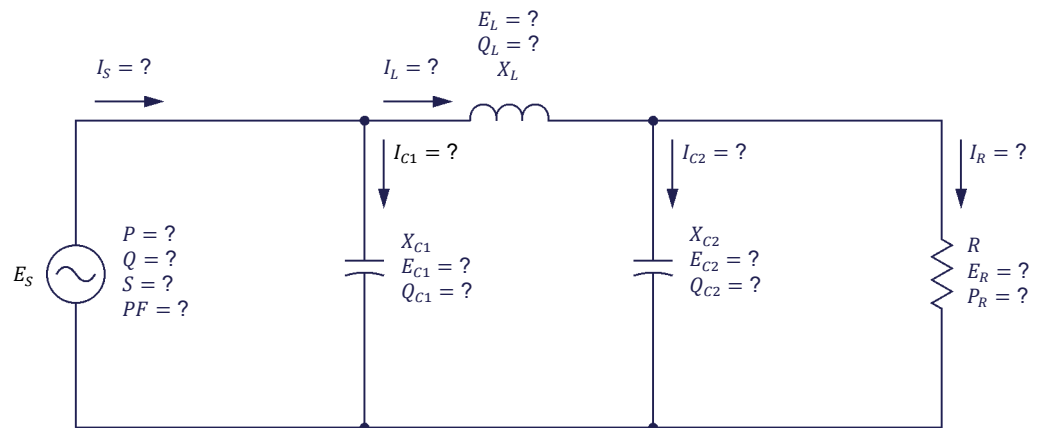

Figure 4-7. AC circuit containing a resistor, an inductor, and two capacitors.

The step-by-step sequence for solving the ac circuit shown in Figure 4-7 using the power triangle method is given below. The values of the source voltage E_S , the resistance R of the resistor, the inductive reactance X_L of the inductor, and the capacitive reactances X_{C1} and X_{C2} of the capacitors are known from the circuit diagram. To solve the circuit using the power triangle method, it is necessary to assume a certain voltage value (determined arbitrarily) across one of the circuit components. In this example, the voltage E_R ($E_R = E_{C2}$) across the resistor is assumed to be equal to x V. This results in the following:

$$I_R = E_R / R = x / R$$

$$P_R = E_R \cdot I_R = x \cdot I_R$$

$$I_{C2} = E_{C2} / X_{C2} = x / X_{C2}$$

$$Q_{C2} = E_{C2} \cdot I_{C2} = x \cdot I_{C2}$$

$$S_{R-C2} = \sqrt{P_R^2 + Q_{C2}^2}$$

$$I_L = S_{R-C2}/E_R = S_{R-C2}/x$$

$$E_L = I_L \cdot X_L$$

$$Q_L = E_L \cdot I_L$$

$$S_{R-L-C2} = \sqrt{P_R^2 + (Q_L - Q_{C2})^2}$$

$$E_S = S_{R-L-C2}/I_L$$

$$I_{C1} = E_S/X_{C1}$$

$$Q_{C1} = E_S \cdot I_{C1}$$

$$P = P_R$$

$$Q = Q_L - (Q_{C1} + Q_{C2})$$

$$S = \sqrt{P^2 + Q^2}$$

$$I_S = S/E_S$$

$$PF = P/S$$

The results of the calculations above are only valid when the actual source voltage is equal to the source voltage E_S calculated above ($E_{S,assumed}$) with the assumed value of resistor voltage E_R . However, all the circuit parameters can easily be recalculated for any actual source voltage E_S by applying a factor of $E_{S,actual}/E_{S,assumed}$ to all the voltage and current values calculated above.

As the demonstration above shows, it is absolutely necessary at some points in the calculations to resort to the power triangle in order to resolve the ac circuit completely without any vectorial calculation. Thus, when using the power triangle method, the power triangle is the key to complete circuit resolution without using vectorial calculation.

Example

Figure 4-8 shows an ac circuit containing a resistor, an inductor, and two capacitors.

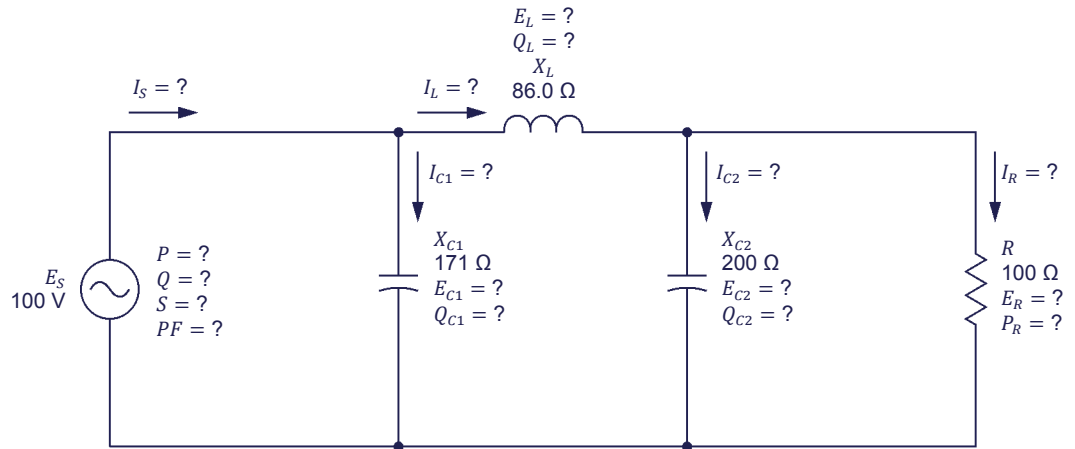

Figure 4-8. AC circuit containing a resistor, an inductor, and two capacitors.

The step-by-step sequence for solving the ac power circuit shown in Figure 4-8 is given below. In the calculations, it is assumed that the voltage E_R ($E_R = E_{C2}$) measured across the resistor is equal to 40.0 V.

$$I_R = E_R/R = 40.0 \text{ V}/100 \Omega = 0.40 \text{ A}$$

$$P_R = E_R \cdot I_R = 40.0 \text{ V} \cdot 0.40 \text{ A} = 16.0 \text{ W}$$

$$I_{C2} = E_{C2}/X_{C2} = 40.0 \text{ V}/200 \Omega = 0.20 \text{ A}$$

$$Q_{C2} = E_{C2} \cdot I_{C2} = 40.0 \text{ V} \cdot 0.20 \text{ A} = 8.00 \text{ var}$$

$$S_{R-C2} = \sqrt{P_R^2 + Q_{C2}^2} = \sqrt{(16.0 \text{ W})^2 + (8.00 \text{ var})^2} = 17.9 \text{ VA}$$

$$I_L = S_{R-C2}/E_R = 17.9 \text{ VA}/40.0 \text{ V} = 0.45 \text{ A}$$

$$E_L = I_L \cdot X_L = 0.45 \text{ A} \cdot 86.0 \Omega = 38.7 \text{ V}$$

$$Q_L = E_L \cdot I_L = 38.7 \text{ V} \cdot 0.45 \text{ A} = 17.4 \text{ var}$$

$$S_{R-L-C2} = \sqrt{P_R^2 + (Q_L - Q_{C2})^2} = \sqrt{(16.0 \text{ W})^2 + (17.4 \text{ var} - 8.00 \text{ var})^2} = 18.6 \text{ VA}$$

$$E_S = S_{R-L-C2}/I_L = 18.6 \text{ VA}/0.45 \text{ A} = 41.3 \text{ V}$$

$$I_{C1} = E_S/X_{C1} = 41.3 \text{ V}/171 \Omega = 0.24 \text{ A}$$

$$Q_{C1} = E_S \cdot I_{C1} = 41.3 \text{ V} \cdot 0.24 \text{ A} = 9.91 \text{ var}$$

$$P = P_R = 16.0 \text{ W}$$

$$Q = Q_L - (Q_{C1} + Q_{C2}) = 17.4 \text{ var} - (9.91 \text{ var} + 8.00 \text{ var}) = -0.51 \text{ var}$$

$$S = \sqrt{P^2 + Q^2} = \sqrt{(16.0 \text{ W})^2 + (0.51 \text{ var})^2} = 16.0 \text{ VA}$$

$$I_S = S/E_S = 16.0 \text{ VA}/41.3 \text{ V} = 0.39 \text{ A}$$

$$PF = P/S = 16.0 \text{ W}/16.0 \text{ VA} = 1.00$$

The values calculated above are valid only if the source voltage E_S is 41.3 V. Knowing that the actual source voltage E_S is 100 V, the assumed resistor voltage E_R has to be multiplied by the ratio $E_{S,actual}/E_{S,assumed}$ in order to obtain the actual value of the resistor voltage E_R . The actual resistor voltage E_R is thus equal to:

$$E_R = E_{R,assumed} \cdot (E_{S,actual}/E_{S,assumed}) = 40.0 \text{ V} \cdot (100 \text{ V}/41.3 \text{ V}) = 96.9 \text{ V}$$

The whole circuit can then be resolved using the value of the actual voltage E_R .

$$I_R = E_R/R = 96.9 \text{ V}/100 \Omega = 0.97 \text{ A}$$

$$P_R = E_R \cdot I_R = 96.9 \text{ V} \cdot 0.97 \text{ A} = 94.0 \text{ W}$$

$$I_{C2} = E_{C2}/X_{C2} = 96.9 \text{ V}/200 \Omega = 0.48 \text{ A}$$

$$Q_{C2} = E_{C2} \cdot I_{C2} = 96.9 \text{ V} \cdot 0.48 \text{ A} = 46.5 \text{ var}$$

$$S_{R-C2} = \sqrt{P_R^2 + Q_{C2}^2} = \sqrt{(94.0 \text{ W})^2 + (46.5 \text{ var})^2} = 105 \text{ VA}$$

$$I_L = S_{R-C2}/E_R = 105 \text{ VA}/96.9 \text{ V} = 1.08 \text{ A}$$

$$E_L = I_L \cdot X_L = 1.08 \text{ A} \cdot 86 \Omega = 92.9 \text{ V}$$

$$Q_L = E_L \cdot I_L = 92.9 \text{ V} \cdot 1.08 \text{ A} = 100 \text{ var}$$

$$S_{R-L-C2} = \sqrt{P_R^2 + (Q_L - Q_{C2})^2} = \sqrt{(94.0 \text{ W})^2 + (100 \text{ var} - 46.5 \text{ var})^2} = 108 \text{ VA}$$

$$E_S = S_{R-L-C2}/I_L = 108 \text{ VA}/1.08 \text{ A} = 100 \text{ V}$$

The value of the source voltage E_S obtained in the previous step confirms that the actual source voltage E_S is effectively equal to 100 V when the resistor voltage E_R is 96.9 V. The remaining circuit parameters can then be calculated:

$$I_{C1} = E_S/X_{C1} = 100 \text{ V}/171 \Omega = 0.58 \text{ A}$$

$$Q_{C1} = E_S \cdot I_{C1} = 100 \text{ V} \cdot 0.58 \text{ A} = 58.0 \text{ var}$$

$$P = P_R = 94.0 \text{ W}$$

$$Q = Q_L - (Q_{C1} + Q_{C2}) = 100 \text{ var} - (58.0 \text{ var} + 46.5 \text{ var}) = -4.50 \text{ var}$$

$$S = \sqrt{P^2 + Q^2} = \sqrt{(94.0 \text{ W})^2 + (-4.50 \text{ var})^2} = 94.1 \text{ VA}$$

$$I_S = S/E_S = 94.1 \text{ VA}/100 \text{ V} = 0.94 \text{ A}$$

$$PF = P/S = 94.0 \text{ W}/94.1 \text{ VA} = 1.00$$

PROCEDURE OUTLINE

The Procedure is divided into the following sections:

- Setup and connections
- Solving an ac circuit using the power triangle method

PROCEDURE



High voltages are present in this laboratory exercise. Do not make or modify any banana jack connections with the power on unless otherwise specified.

Setup and connections

In this section, you will connect an ac circuit containing two resistors, an inductor, and a capacitor, and set up the equipment to measure all the circuit parameters.

1. Refer to the Equipment Utilization Chart in Appendix A to obtain the list of equipment required to perform this exercise.

Install the required equipment in the [Workstation](#).

2. Make sure that the main power switch on the [Four-Quadrant Dynamometer/Power Supply](#) is set to the O (off) position, then connect its *Power Input* to an ac power outlet.

Connect the *Power Input* of the [Data Acquisition and Control Interface](#) to a 24 V ac power supply. Turn the 24 V ac power supply on.

3. Connect the USB port of the [Data Acquisition and Control Interface](#) to a USB port of the host computer.

Connect the USB port of the [Four-Quadrant Dynamometer/Power Supply](#) to a USB port of the host computer.

4. Turn the [Four-Quadrant Dynamometer/Power Supply](#) on, then set the *Operating Mode* switch to *Power Supply*.

5. Turn the host computer on, then start the LVDAC-EMS software.

In the LVDAC-EMS Start-Up window, make sure that the Data Acquisition and Control Interface and the Four-Quadrant Dynamometer/Power Supply are detected. Make sure that the Computer-Based Instrumentation function for the Data Acquisition and Control Interface is available. Select the network voltage and frequency that correspond to the voltage and frequency of your local ac power network, then click the OK button to close the LVDAC-EMS Start-Up window.

6. Set up the circuit shown in Figure 4-9.

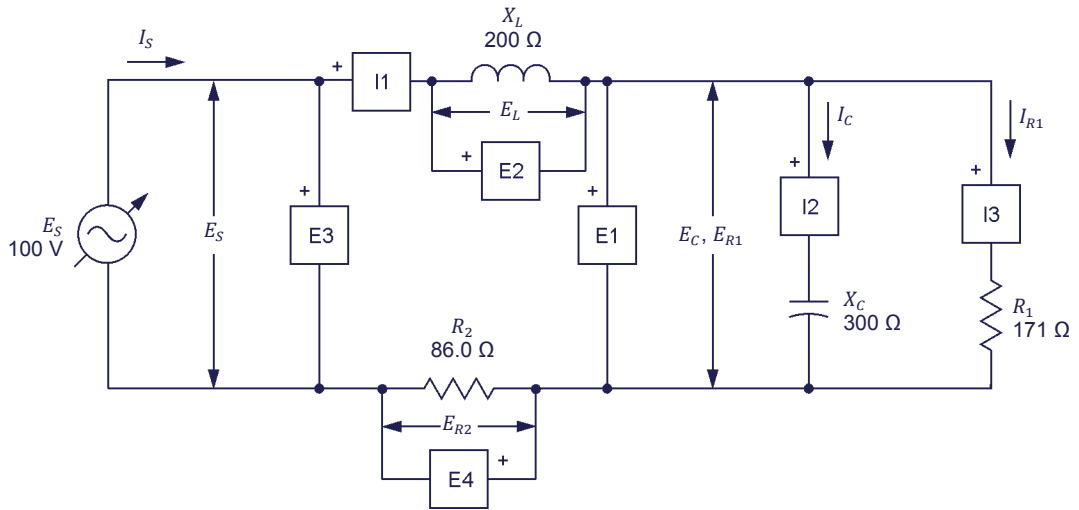

Figure 4-9. AC circuit containing two resistors, an inductor, and a capacitor, and set up for circuit analysis.

Make the necessary switch settings on the Resistive Load, and on the Inductive Load and Capacitive Load (or on the Inductive and Capacitive Loads) in order to obtain the resistance, inductive reactance, and capacitive reactance values required.

Use inputs E1, E2, E3, and E4 of the Data Acquisition and Control Interface to measure the source voltage E_S , the inductor voltage E_L , the capacitor voltage E_C ($E_C = E_{R1}$), and the voltage E_{R2} across resistor R_2 , respectively. Use inputs I1, I2, and I3 to measure the source current I_S ($I_S = I_L = I_{R2}$), the capacitor current I_C , and the current I_{R1} flowing in resistor R_1 , respectively.

7. In LVDAC-EMS, open the Four-Quadrant Dynamometer/Power Supply window, then make the following settings:
 - Set the Function parameter to AC Power Source.
 - Make sure that the Voltage Control parameter is set to Knob. This allows the ac power source to be controlled manually.
 - Set the No Load Voltage parameter to 100 V.

- Set the *Frequency* parameter to the frequency of your local ac power network.
- Leave the other parameters set as they are.

Solving an ac circuit using the power triangle method

In this section, you will use the power triangle method to solve the circuit you set up in the previous steps. You will then measure the circuit parameters and compare the results with the calculated circuit parameters.

8. Resolve the entire circuit of Figure 4-9 using the power triangle method. Assume that the capacitor voltage E_C ($E_C = E_{R1}$) is equal to 50.0 V.

Resistor current $I_{R1} = \underline{\hspace{2cm}}$ A

Active power $P_{R1} = \underline{\hspace{2cm}}$ W

Capacitor current $I_C = \underline{\hspace{2cm}}$ A

Reactive power $Q_C = \underline{\hspace{2cm}}$ var

Apparent power $S_{R1-C} = \underline{\hspace{2cm}}$ VA

Source current $I_S = I_L = I_{R2} = \underline{\hspace{2cm}}$ A

Inductor voltage $E_L = \underline{\hspace{2cm}}$ V

Reactive power $Q_L = \underline{\hspace{2cm}}$ var

Resistor voltage $E_{R2} = \underline{\hspace{2cm}}$ V

Active power $P_{R2} = \underline{\hspace{2cm}}$ W

Active power $P = \underline{\hspace{2cm}}$ W

Reactive power $Q = \underline{\hspace{2cm}}$ var

Apparent power $S = \underline{\hspace{2cm}}$ VA

Source voltage $E_S = \underline{\hspace{2cm}}$ V

Power factor $PF = \underline{\hspace{2cm}}$

9. In LVDAC-EMS, open the *Metering* window. Set meter *E3* to measure the rms value of the ac power source voltage E_S .

In the *Four-Quadrant Dynamometer/Power Supply* window, enable the ac power source. Readjust the value of the *No Load Voltage* parameter so

that the ac power source voltage E_S (indicated by meter $E3$ in the Metering window) is equal to 100 V.

10. In the Metering window, set the meters to measure the following parameters:

Resistor voltage $E_{R1} = \underline{\hspace{2cm}}$ V

Capacitor voltage $E_C = \underline{\hspace{2cm}}$ V

Inductor voltage $E_L = \underline{\hspace{2cm}}$ V

Source voltage $E_S = \underline{\hspace{2cm}}$ V

Resistor voltage $E_{R2} = \underline{\hspace{2cm}}$ V

Source current $I_S = \underline{\hspace{2cm}}$ A

Capacitor current $I_C = \underline{\hspace{2cm}}$ A

Resistor current $I_{R1} = \underline{\hspace{2cm}}$ A

Active power $P_{R1} = \underline{\hspace{2cm}}$ W

Active power $P_{R2} = \underline{\hspace{2cm}}$ W

Reactive power $Q_L = \underline{\hspace{2cm}}$ var

Reactive power $Q_C = \underline{\hspace{2cm}}$ var

Active power $P = \underline{\hspace{2cm}}$ W

Reactive power $Q = \underline{\hspace{2cm}}$ var

Apparent power $S = \underline{\hspace{2cm}}$ VA

Power factor $PF = \underline{\hspace{2cm}}$

11. Compare the circuit parameters measured in the previous step with the circuit parameters you calculated in step 8. Are the values close to each other?

Yes No

12. In the Four-Quadrant Dynamometer/Power Supply window, disable the ac power source.

13. Close LVDAC-EMS, then turn off all the equipment. Disconnect all leads and return them to their storage location.

3. Calculate the actual total reactive power Q in the ac circuit of Figure 4-10 using the parameter values you calculated in the previous questions.

4. Calculate the actual source voltage E_s in the ac circuit of Figure 4-10 using the parameter values you calculated in the previous questions.

5. Calculate the power factor PF of the ac circuit in Figure 4-10 using the parameter values you calculated in the previous questions.

Unit Test

For the first three questions in this Unit Test, refer to the following figure:

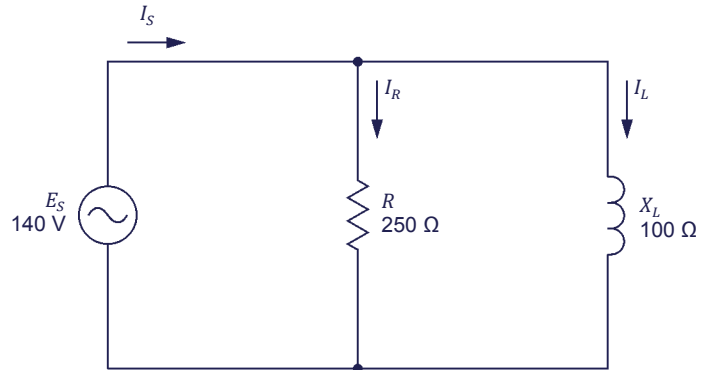

Figure 4-11. Parallel ac circuit containing a resistor and an inductor.

1. Calculate the active power P dissipated in the resistor in the circuit of Figure 4-11.
 - a. $P = 56.0 \text{ W}$
 - b. $P = 92.9 \text{ W}$
 - c. $P = 78.4 \text{ W}$
 - d. $P = 140 \text{ W}$
2. Calculate the impedance Z in the circuit of Figure 4-11.
 - a. $Z = 92.9 \Omega$
 - b. $Z = 269 \Omega$
 - c. $Z = 250 \Omega$
 - d. $Z = 78.4 \Omega$
3. Calculate the apparent power S in the circuit of Figure 4-11.
 - a. $S = 196 \text{ VA}$
 - b. $S = 78.4 \text{ VA}$
 - c. $S = 350 \text{ VA}$
 - d. $S = 211 \text{ VA}$

For questions 4 to 10 of this Unit Test, refer to the following figure:

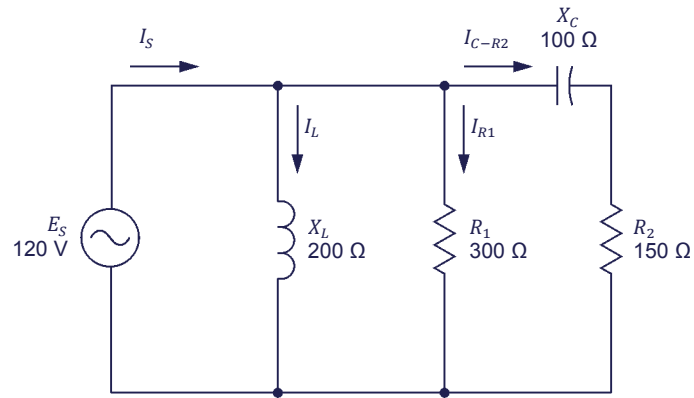

Figure 4-12. AC circuit containing two resistors, an inductor, and a capacitor.

4. Calculate the active power P_{R2} dissipated in the second resistor (R_2) in the circuit of Figure 4-12.
 - a. $P_{R2} = 67.3 \text{ W}$
 - b. $P_{R2} = 33.3 \text{ W}$
 - c. $P_{R2} = 44.4 \text{ W}$
 - d. $P_{R2} = 48.2 \text{ W}$

5. Calculate the apparent power S_{C-R2} in the capacitor and the second resistor (R_2) in the circuit of Figure 4-12.
 - a. $S_{C-R2} = 44.4 \text{ VA}$
 - b. $S_{C-R2} = 80.1 \text{ VA}$
 - c. $S_{C-R2} = 120 \text{ VA}$
 - d. $S_{C-R2} = 118 \text{ VA}$

6. Calculate the active power P_{R1} dissipated in the first resistor (R_1) in the circuit of Figure 4-12.
 - a. $P_{R1} = 66.6 \text{ W}$
 - b. $P_{R1} = 115 \text{ W}$
 - c. $P_{R1} = 12.0 \text{ W}$
 - d. $P_{R1} = 48.0 \text{ W}$

7. Calculate the total reactive power Q in the circuit of Figure 4-12.
 - a. $Q = 44.4 \text{ var}$
 - b. $Q = 72.2 \text{ var}$
 - c. $Q = 27.1 \text{ var}$
 - d. $Q = 118 \text{ var}$

8. Calculate the apparent power S in the circuit of Figure 4-12.
- $S = 29.5 \text{ VA}$
 - $S = 118 \text{ VA}$
 - $S = 164 \text{ VA}$
 - $S = 80.1 \text{ VA}$
9. Calculate the source current I_S in the circuit of Figure 4-12.
- $I_S = 0.98 \text{ A}$
 - $I_S = 0.40 \text{ A}$
 - $I_S = 0.67 \text{ A}$
 - $I_S = 0.60 \text{ A}$
10. Calculate the power factor PF of the circuit shown in Figure 4-12.
- $PF = 0.24$
 - $PF = 1.03$
 - $PF = 0.97$
 - $PF = 0.67$

Equipment Utilization Chart

Equipment		Exercise									
Model	Description	1-1	1-2	1-3	2-1	2-2	2-3	3-1	3-2	4-1	4-2
8131 ⁽¹⁾	Workstation	1	1	1	1	1	1	1	1	1	1
8311	Resistive Load	1	1	1			1	1	1	1	1
8321 ⁽²⁾	Inductive Load		1		1		1	1	1	1	1
8331 ⁽²⁾	Capacitive Load		1			1	1	1	1	1	1
8333 ⁽³⁾	Inductive and Capacitive Loads		1		1	1	1	1	1	1	1
8951-L	Connection Leads	1	1	1	1	1	1	1	1	1	1
8960-C ⁽⁴⁾	Four-Quadrant Dynamometer/Power Supply	1	1	1	1	1	1	1	1	1	1
8990	Host Computer	1	1	1	1	1	1	1	1	1	1
9063-B ⁽⁵⁾	Data Acquisition and Control Interface	1	1	1	1	1	1	1	1	1	1
30004-2	24 V AC Power Supply	1	1	1	1	1	1	1	1	1	1

⁽¹⁾ Workstation models 8110 and 8134 can also be used.
⁽²⁾ The Inductive Load, model 8321, and the Capacitive Load, model 8331, are used only when the ac power network frequency is 60 Hz.
⁽³⁾ The Inductive and Capacitive Loads, model 8333, is used only when the ac power network frequency is 50 Hz.
⁽⁴⁾ Model 8960-C consists of the Four-Quadrant Dynamometer/Power Supply, Model 8960-2, with functions 8968-1 and 8968-2.
⁽⁵⁾ Model 9063-B consists of the Data Acquisition and Control Interface, Model 9063, with function 9069-1.

Glossary of New Terms

active power	The power dissipated in a resistive component is referred to as the active power P , expressed in watts (W). Active power, as opposed to reactive power, is used by the resistive component to perform work and is not returned to the source. The amount of active power in a component is equal to the average value of the power waveform and can be determined by multiplying the rms values of the voltage and current related to the component.
amplitude	The amplitude A of a sine wave is the maximum value reached by the sine wave during its cycle. The maximum value is the same for both the positive and negative half-waves of the cycle, except for the polarity which changes from positive (+) to negative (–).
apparent power	The apparent power S in an ac circuit is equal to the vectorial sum of the active power and reactive power in the circuit. Apparent power S is expressed in volt-amperes (VA) and can be calculated using the following equation: $S = \sqrt{P^2 + Q^2}$.
average power	The average power P_{Avg} supplied to a circuit component corresponds to the average value of the power waveform related to the component and is equal to the active power dissipated in that component. Thus, in a purely resistive component, the average power is equal to the product of the rms values of the voltage and current related to the component. In the case of purely reactive components, the average power is null.
capacitance	The defining characteristic of a capacitor is its capacitance C , expressed in microfarads (μF). Capacitance is one of the main factors that determine the opposition to current flow of a capacitor, i.e., its capacitive reactance X_C .
capacitive reactance	The capacitive reactance X_C of a capacitor determines the opposition to current flow of the capacitor in ac circuits and is expressed in ohms. The capacitive reactance X_C is inversely proportional to the capacitance C of the capacitor and the frequency f of the ac power source ($X_C = 1/2\pi fC$).
capacitor	A capacitor basically consists of two plates of a conductive material (generally a metal) separated by an insulating material. Capacitors, as inductors, oppose current flow in ac circuits. The opposition to current flow of a capacitor is determined by its capacitance. The current flowing in a capacitor leads the voltage across the capacitor by 90° .
frequency	The frequency f of a sine wave, expressed in hertz (Hz), indicates the number of times the sine wave cycle repeats itself in a second. The frequency of a sine wave is inversely proportional to the period of the sine wave ($f = 1/T$).
impedance	The impedance Z is the total opposition to current flow caused by an array of resistive and reactive components in an ac circuit. Impedance is measured in ohms Ω .

inductance	The defining characteristic of an inductor is its inductance L , expressed in henries (H). Inductance is one of the main factors that determine the opposition to current flow of an inductor, i.e., its inductive reactance X_L .
inductive reactance	The inductive reactance X_L of an inductor determines the opposition to current flow of the inductor and is expressed in ohms. The inductive reactance X_L is directly proportional to the inductance L of the inductor and the frequency f of the ac power source ($X_L = 2\pi fL$).
inductor	An inductor consists basically of a coil of wire wound around an iron core. Inductors, as capacitors, oppose current flow in ac circuits. The opposition to current flow of an inductor is determined by its inductance. The current flowing in an inductor lags the voltage measured across the inductor by about 90° .
instantaneous power	Instantaneous power P is the product of the rms values of the voltage and current related to a circuit component at each instant of a sine wave cycle. The waveform of instantaneous power P (or power waveform) is a squared sine wave having a frequency that is twice the source frequency.
lagging	A lagging sine wave is a sine wave whose phase angle is inferior to that of the reference sine wave. In other words, a lagging sine wave occurs after the reference sine wave. A lagging waveform is shifted to the right of the reference waveform on a graph or an oscilloscope display.
leading	A leading sine wave is a sine wave whose phase angle is superior to that of the reference sine wave. In other words, a leading sine wave occurs before the reference sine wave. A leading waveform is shifted to the left of the reference waveform on a graph or an oscilloscope display.
negative half-wave	The negative half-wave of a sine wave cycle is the portion of the sine wave having a negative (-) polarity.
period	The period T of a sine wave, expressed in seconds (s), indicates the time required for one complete sine wave cycle to occur. The period of a sine wave is inversely proportional to the frequency of the sine wave ($T = 1/f$).
phase angle	The phase angle θ of a sine wave determines the initial value (i.e., the value at $t = 0$) of the sine wave. In other words, the phase angle θ determines by how much the value of a sine wave differs from 0 at time $t = 0$, and thus, the position in time of the sine wave.
phase shift	The phase shift between two sine waves having the same frequency measures the difference between the phase angle of each sine wave. The phase shift indicates the extent of the separation in time between the two sine waves, as well as the relationship between the sine waves, i.e., leading, lagging, or in phase.

phasor	A phasor is a vector having its origin at the center (0, 0) of a cartesian plane. A phasor is used to represent a sine wave whose amplitude A , phase angle θ , and frequency f do not vary in time (e.g., the voltage, current, or power related to a circuit component).
positive half-wave	The positive half-wave of a sine wave is the portion of a sine wave cycle having a positive (+) polarity.
power factor	The power factor PF of a circuit is the ratio between the active power P and the apparent power S in the circuit ($PF = P/S$). The power factor PF of a circuit is a dimensionless quantity that varies between 0 (indicating a purely reactive circuit) and 1 (indicating a purely resistive circuit).
power triangle	The power triangle related to an ac circuit is a trigonometric representation of the relationship between the active power P , reactive power Q , and apparent power S (the adjacent side, the opposite side, and the hypotenuse of a right triangle, respectively) in the circuit. Using the laws of trigonometry, it is possible to calculate the length of any side when the other two are known.
reactance	In an ac circuit, the reactance X of a component determines its opposition to current flow. Reactance can be of two types, inductive or capacitive, and is expressed in ohms (Ω).
reactive power	The power in a reactive component (an inductor or a capacitor) is referred to as the reactive power Q , expressed in reactive volt-amperes (var). Reactive power, as opposed to active power, is not used by the reactive component to perform work and is returned to the source. The amount of reactive power in a component can be determined by multiplying the rms values of the voltage and current related to the component.
vector	A vector is the graphical representation of a quantity having a magnitude and a direction.

Impedance Table for the Load Modules

The following table gives impedance values which can be obtained using either the [Resistive Load](#), Model 8311, the [Inductive Load](#), Model 8321, the [Capacitive Load](#), Model 8331, and the [Inductive and Capacitive Loads](#), Model 8333. Figure C-1 and Figure C-2 show the load elements and connections. Other parallel combinations can be used to obtain the same impedance values listed.

Table C-1. Impedance table for the load modules.

Impedance (Ω)	Position of the switches								
	1	2	3	4	5	6	7	8	9
1200									
600									
300									
400									
240									
200									
171									
150									
133									
120									
109									
100									
92									
86									
80									
75									
71									
67									
63									
60									
57									

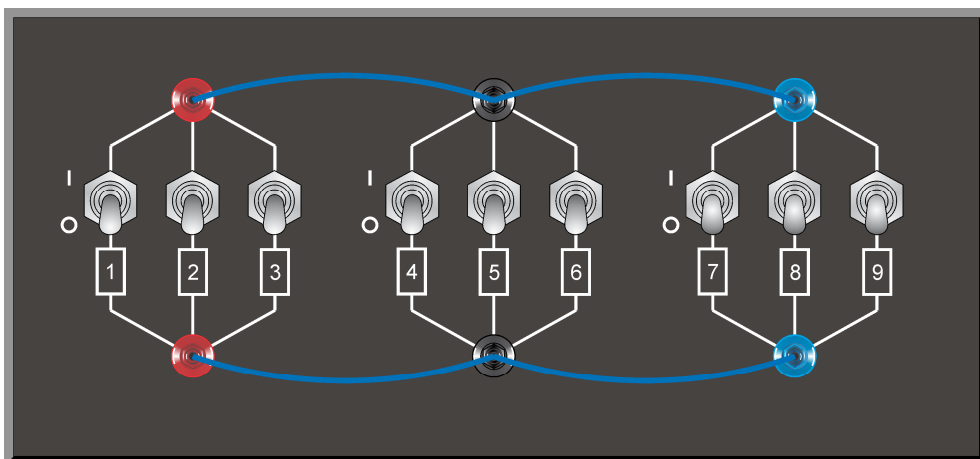

Figure C-1. Location of the load elements on the **Resistive Load, Inductive Load, and Capacitive Load, Models 8311, 8321, and 8331, respectively.**

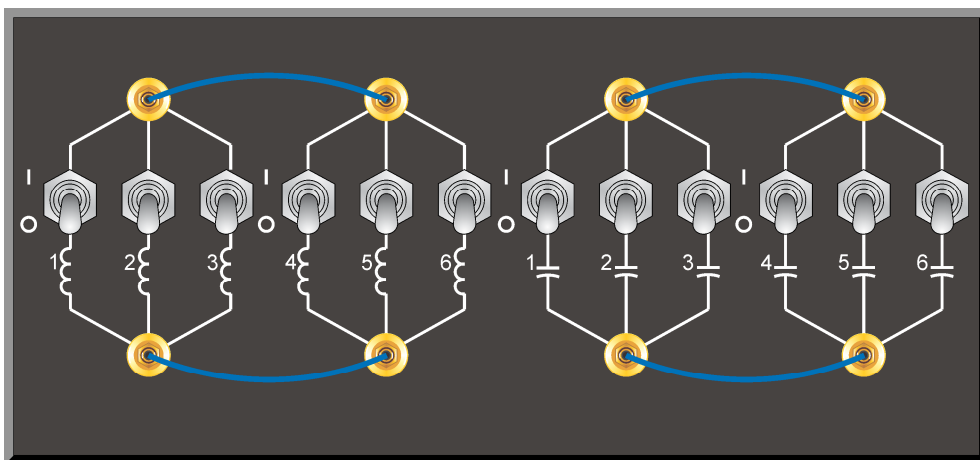

Figure C-2. Location of the load elements on the **Inductive and Capacitive Loads, Model 8333.**

Vectorial Calculations

As stated in Exercise 2-3, each parameter of an ac power circuit (e.g., voltage, current, power) can be represented as a phasor, i.e., a vector having its beginning at the origin (0, 0) of a cartesian plane. The length of the phasor is determined by the magnitude of the parameter that the phasor represents, while the angular position (direction) of the phasor is determined by the phase angle of the parameter. The horizontal axis of the cartesian plane is called the real axis, while the vertical axis is called the imaginary axis.

To perform mathematical operations on one or more phasors (as is required in Exercise 2-3 and Exercise 3-2), it is necessary to represent the phasors in the polar form. In the polar form, a phasor P is expressed in the following way:

$$P = C \angle \theta$$

where P is the phasor.

C is the scalar magnitude of the phasor (corresponding to the value of the parameter that the phasor represents).

θ is the angle of the phasor with respect to the horizontal axis, expressed in degrees ($^{\circ}$).

For example, consider the figure below showing the phasors of the resistance R , inductive reactance X_L , and impedance Z related to a resistor and an inductor connected in series.

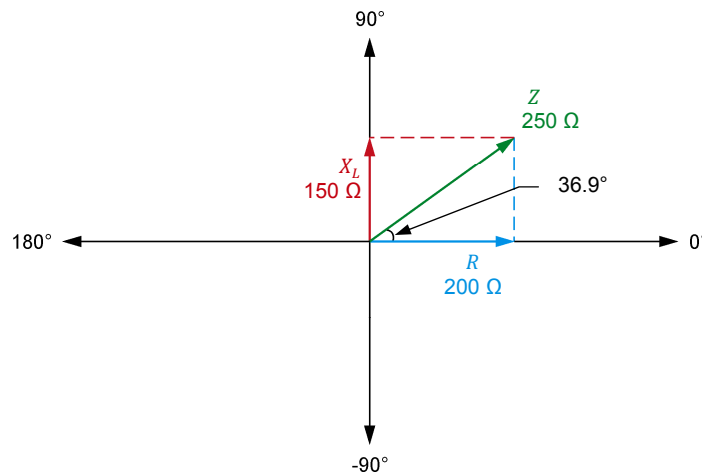

Figure D-1. Phasor diagram showing the resistance R , inductive reactance X_L , and impedance Z related to a resistor and an inductor connected in series.

In Figure D-1, the polar form of the phasor of the resistance R is $200 \angle 0^{\circ}$, while the polar form of the phasor of the inductive reactance X_L is $150 \angle 90^{\circ}$. The angle θ of the impedance Z can be calculated using the Pythagorean Theorem [$\theta = \tan^{-1}(150/200) = 36.9^{\circ}$]. The polar form of the phasor of the impedance Z is thus $250 \angle 36.9^{\circ}$.

When the value of the angle θ of a phasor is negative, it indicates that the phasor has a negative value on the vertical axis. The polar notation of the capacitive reactance X_C of a capacitor is thus $X_C \angle -90^\circ$.

Vectorial division

In Exercise 2-3, it is necessary to divide phasors in order to obtain the phasor diagrams related to a resistor, an inductor, and a capacitor. When dividing two phasors $P_1 (C \angle \theta_1)$ and $P_2 (D \angle \theta_2)$, the following equation is used:

$$\frac{P_1}{P_2} = \frac{C \angle \theta_1}{D \angle \theta_2} = \frac{C}{D} \angle (\theta_1 - \theta_2)$$

Figure D-2 shows the phasor diagram related to an ideal inductor in an ac circuit.

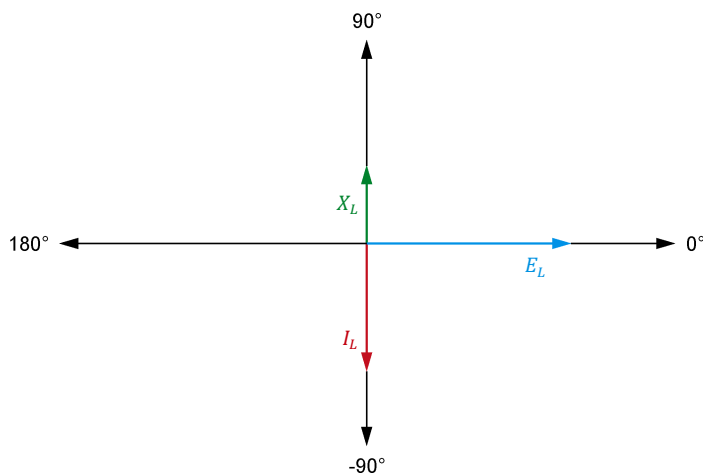

Figure D-2. Phasor diagram of the voltage E_L , current I_L , and inductive reactance X_L related to an inductor.

Figure D-2 shows that the phasor of the inductive reactance X_L is 180° out of phase with respect to the phasor of the inductor current I_L . This is because the inductive reactance X_L results from the division of the phasor of the inductor voltage by the phasor of the inductor current, as shown in the calculations below.

$$X_L = \frac{E_L}{I_L} = \frac{E_L \angle 0^\circ}{I_L \angle -90^\circ} = \frac{E_L}{I_L} \angle 0^\circ - (-90^\circ)$$

$$X_L = \frac{E_L}{I_L} \angle 90^\circ$$

Similarly, the phasor of the capacitive reactance X_C of a capacitor is also 180° out of phase with respect to the capacitor current I_C , as shown in the calculations below.

$$X_C = \frac{E_C}{I_C} = \frac{E_C \angle 0^\circ}{I_C \angle 90^\circ} = \frac{E_C}{I_C} \angle 0^\circ - (90^\circ)$$

$$X_C = \frac{E_C}{I_C} \angle -90^\circ$$

Vectorial multiplication

In Exercise 3-2, it is necessary to multiply phasors in order to obtain the phasor diagrams related to the active power and reactive power in an ac circuit. When multiplying two phasors $P_1 (C \angle \theta_1)$ and $P_2 (D \angle \theta_2)$, the following equation is used:

$$P_1 \times P_2 = C \angle \theta_1 \times D \angle \theta_2 = (C \times D) \angle (\theta_1 + \theta_2)$$

Figure D-3 shows an ac circuit containing a capacitor and the phasor diagrams related to the capacitor.

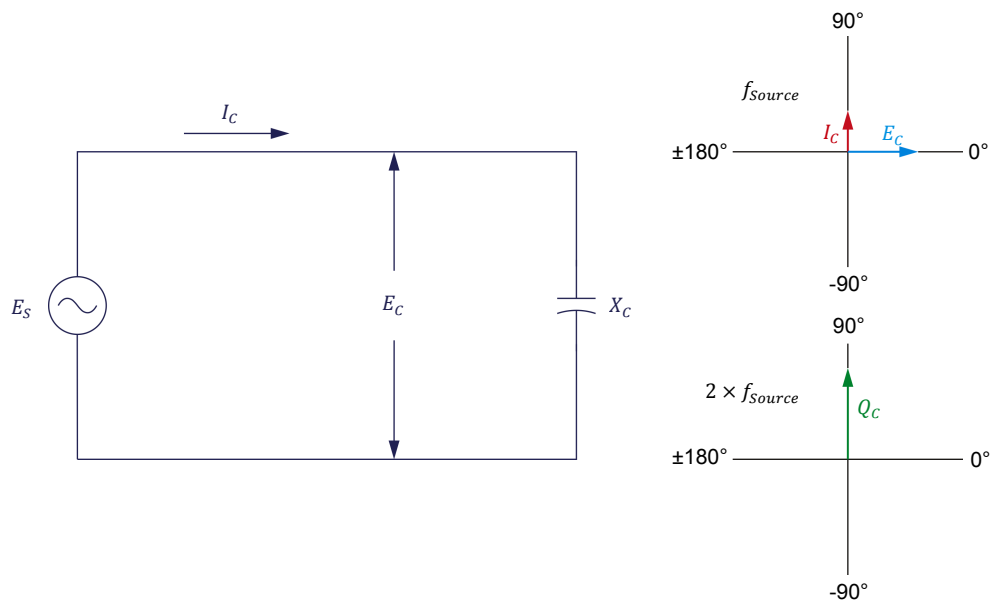

Figure D-3. AC circuit containing a capacitor and phasor diagrams related to the capacitor.

Figure D-3 shows that the phase angle (90°) of the phasor representing the reactive power Q_C in the capacitor has the same value as that of the phasor representing the capacitor current I_C . This is because the reactive power Q_C results from the multiplication of the phasors of the capacitor voltage E_C and current I_C , as shown in the calculations below.

$$Q_C = E_C \times I_C = E_C \angle 0^\circ \times I_C \angle 90^\circ = (E_C \times I_C) \angle (0^\circ + 90^\circ)$$

$$Q_C = (E_C \times I_C) \angle 90^\circ$$

Similarly, the phase angle (-90°) of the phasor representing the reactive power Q_L in an inductor has the same value as that of the phasor representing the inductor current I_L , as shown in the calculations below.

$$Q_L = E_L \times I_L = E_L \angle 0^\circ \times I_L \angle -90^\circ = (E_L \times I_L) \angle [0^\circ + (-90^\circ)]$$

$$Q_L = (E_L \times I_L) \angle -90^\circ$$

Circuit Diagram Symbols

Various symbols are used in the circuit diagrams of this manual. Each symbol is a functional representation of a particular electrical device that can be implemented using Lab-Volt equipment. The use of these symbols greatly simplifies the number of interconnections that need to be shown on the circuit diagram, and thus, makes it easier to understand the circuit operation.

For each symbol other than those of power sources, resistors, inductors, and capacitors, this appendix gives the name of the device which the symbol represents, as well as the equipment and the connections required to properly connect the device to a circuit. Notice that the terminals of each symbol are identified using circled letters. The same circled letters identify the corresponding terminals in the Equipment and Connections diagram. Also notice that the numbers (when present) in the Equipment and Connections diagrams correspond to terminal numbering used on the actual equipment.

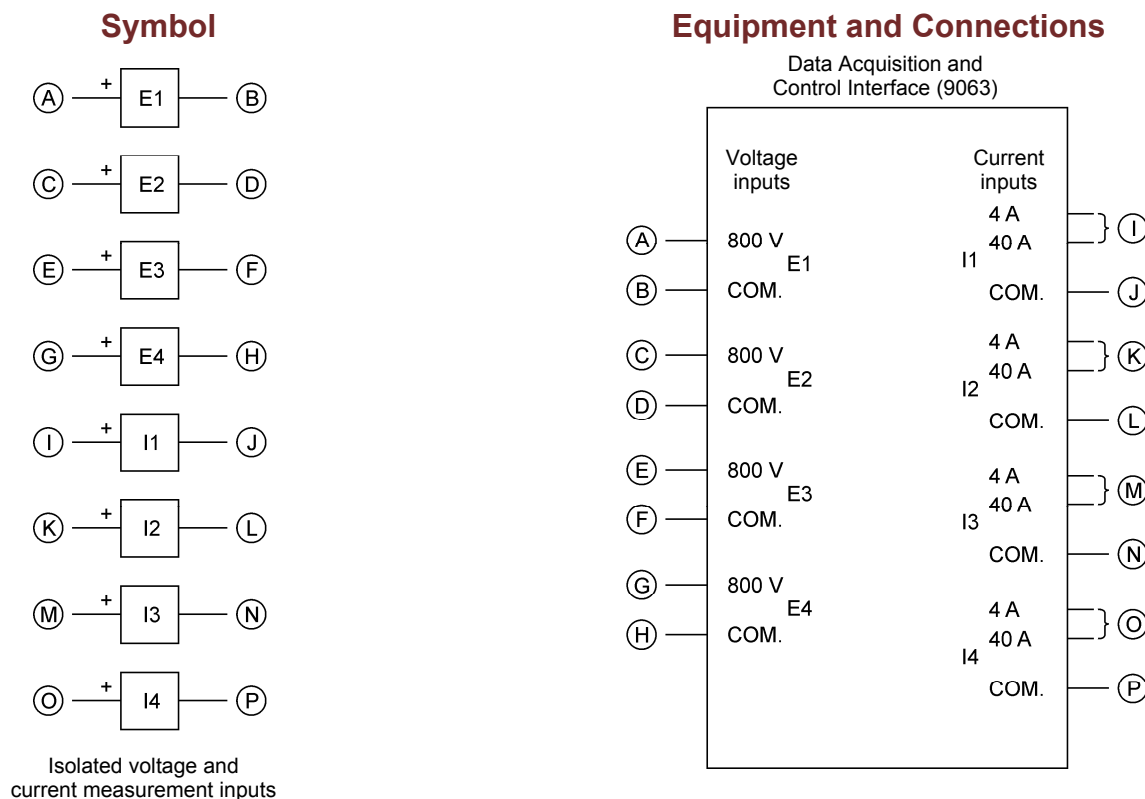

When a current at inputs I1, I2, I3, or I4 exceeds 4 A (either permanently or momentarily), use the corresponding 40 A input terminal and set the Range parameter of the corresponding input to High in the Data Acquisition and Control Settings window of LVDAC-EMS.

Symbol

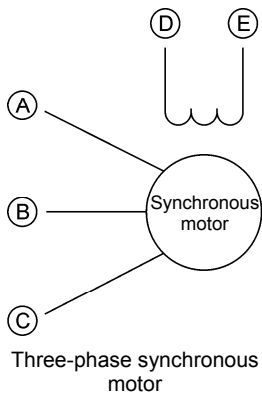
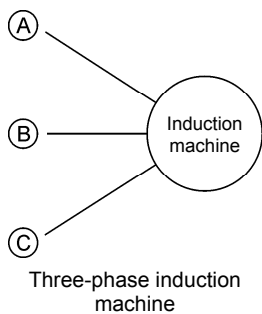
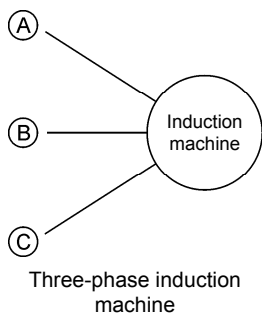

Equipment and Connections

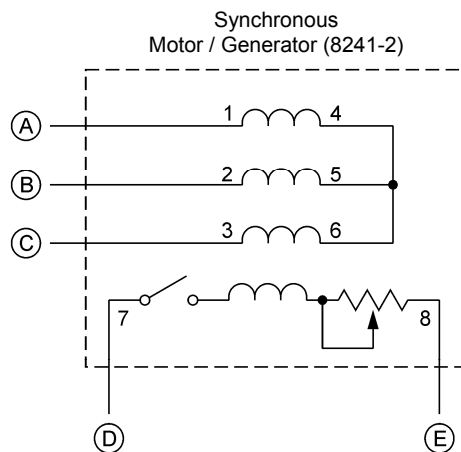
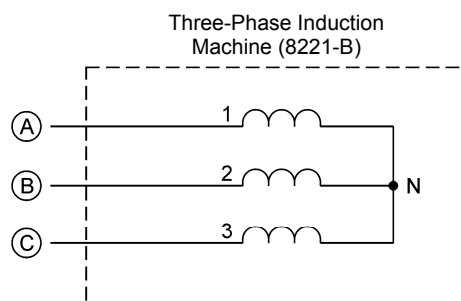
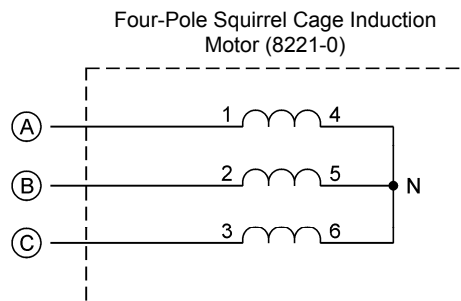

Symbol

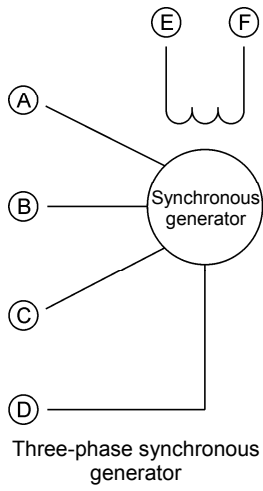

Equipment and Connections

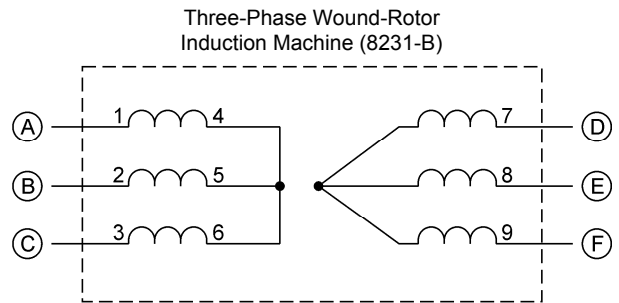
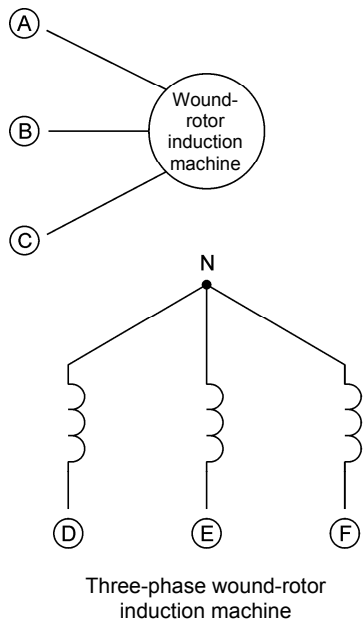
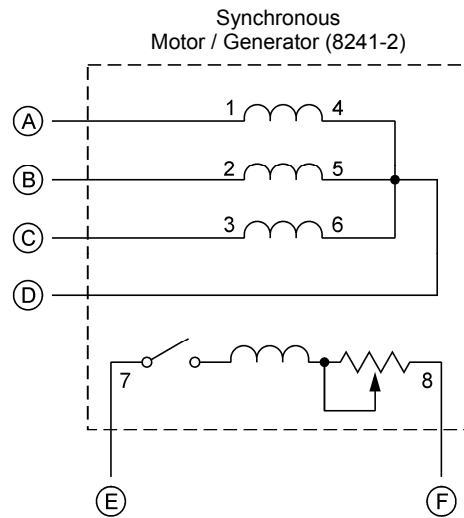

Symbol

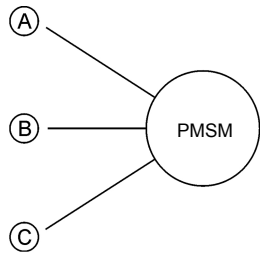

Permanent Magnet Synchronous Machine

Equipment and Connections

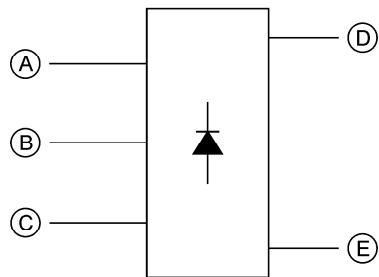
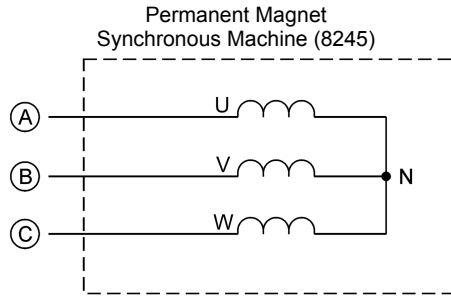

Power diode three-phase full-wave rectifier

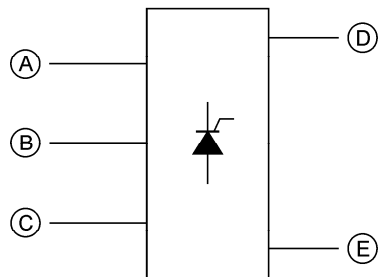
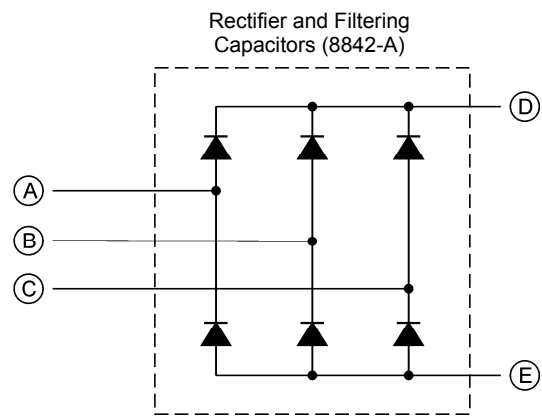

Power thyristor three-phase bridge

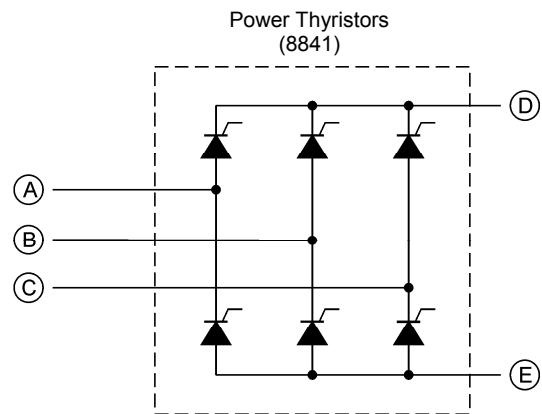

Symbol

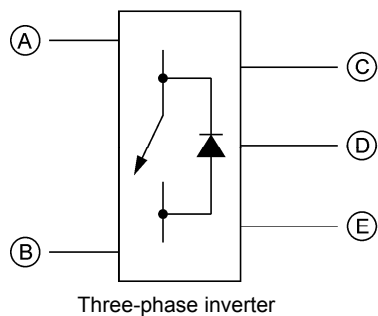

Equipment and Connections

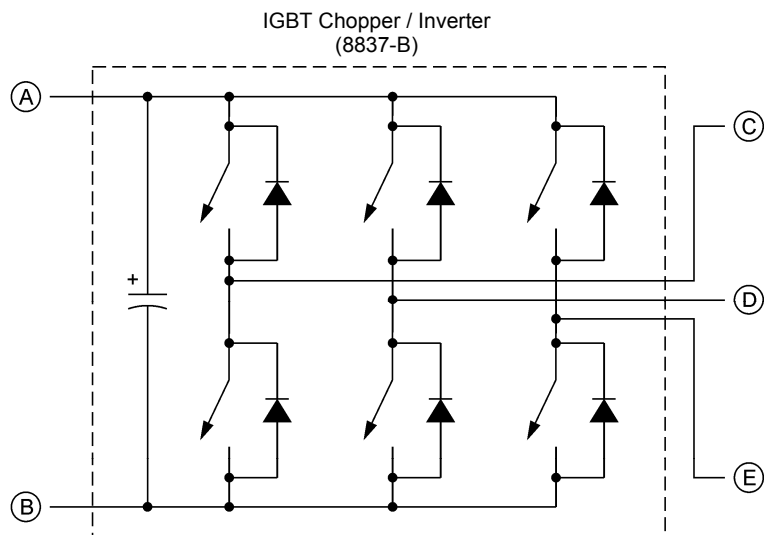

Index of New Terms



The bold page number indicates the main entry. Refer to the Glossary of New Terms sur la page 157 for definitions of new terms.

active power	95 , 97, 98, 99, 100, 111, 114, 115, 116, 127
amplitude.....	1, 5, 8 , 9, 10, 23
apparent power	95 , 111, 115, 116, 127
average power	1, 35 , 36, 37, 97, 98, 99
capacitance	61
capacitive reactance	49 , 61, 73, 74, 80, 131, 141
capacitors.....	37, 47 , 48, 49, 61, 62, 76, 141, 143
frequency	1, 3 , 5, 8, 11, 23, 24, 36, 51, 61, 95, 98, 111, 112, 113
impedance.....	49 , 71, 75, 76, 77, 78, 127, 129, 130, 131, 132
inductance.....	51 , 52
inductive reactance	48 , 72, 73, 74, 80, 131, 141
inductors.....	37, 47 , 48, 49, 51, 52, 61, 62, 76, 99, 113
instantaneous power	35 , 36, 97, 98, 99
lagging.....	21, 23 , 24, 25
leading.....	21, 23 , 24, 25
negative half-wave	2 , 35
period	1, 5, 8 , 11, 23, 24, 36
phase angle.....	21 , 22, 23, 24, 71, 111, 113
phase shift.....	21, 23 , 24, 25, 47, 52, 62, 95
phasor	5 , 6, 23, 71, 72, 73, 74, 75, 76, 95, 111, 112, 113, 115
positive half-wave.....	2 , 35
power factor	95, 111, 115 , 116, 127
power triangle.....	95 , 111, 115, 127, 141, 142
reactance	48 , 49, 51, 52, 71, 73, 75, 76, 77, 129
reactive power.....	95 , 97, 99, 100, 111, 112, 113, 114, 115, 116, 127
vector	5 , 71

Bibliography

Boylestad, Robert L., *Introductory Circuit Analysis*, 11th ed., Upper Saddle River: Prentice Hall, 2006, ISBN 978-0131730441.

Wildi, Theodore, *Electrical Machines, Drives, and Power Systems*, 6th ed., Upper Saddle River: Prentice Hall, 2005, ISBN 978-0131776913.

We Value Your Opinion!

Your comments and suggestions help us produce better manuals and develop innovative systems to meet the needs of our users. Please contact us by e-mail at:

services@labvolt.com

For further information, visit our website at www.labvolt.com.