

GREDI
Groupe de Recherche en Économie
et Développement International



Cahier de recherche / Working Paper
17-05

**Credit Crunch and
Downward Nominal Wage Rigidities**

Jean-François ROUILLARD



UNIVERSITÉ DE
SHERBROOKE

Credit Crunch and Downward Nominal Wage Rigidities

Jean-François Rouillard*

Université de Sherbrooke

April 21, 2019

Abstract

Through the lens of a dynamic general equilibrium model that features financial frictions and downward nominal wage rigidities (DNWR), I simulate a credit crunch similar to the one experienced by the US during the 2007-09 recession. Since the constraint on nominal wage inflation binds, this induces important cutbacks in hours worked. For a 2% inflation-target regime, the maximal deviation of hours worked is 2.15 greater with DNWR than with flexible wages. Total losses in hours worked are also 27% lower when the inflation target is elevated from 2% to 4%. Moreover, the model can account for a large part of the upward shift in the labor wedge that occurred during the recession. This result arises because the marginal rate of substitution of consumption for leisure significantly deviates from real wages with DNWR.

Key words: borrowing constraints, monetary policy, inflation target, labor wedge

JEL classification: E24, E32, E44, E52

*Department of Economics, Université de Sherbrooke, Sherbrooke, Québec, Canada. *E-mail:* j-f.rouillard@usherbrooke.ca. This paper has benefited from the insightful comments of Alessandro Barattieri, Hashmat Khan and Heejeong Kim. I also thank participants at the Midwest Macroeconomics Meetings in Nashville (November 2018) and in seminars at UQÀM and Université de Sherbrooke.

1 Introduction

During the Great Recession, the distribution of yearly nominal wage changes was left-skewed in the US and featured a much higher-than-usual spike at zero. Additionally, despite being characterized as the deepest recession since the Great Depression, the employment cost index (ECI) rose during that period. In Table 1, I present the average annualized growth rates in the ECI. As can be seen, these rates are not that much lower during the Great Recession than during the period that spans from 2001Q1 to 2018Q4. These stylized facts suggest that downward nominal wage rigidities (DNWR) have stayed strong even during harsh economic conditions.¹ Another characteristic of the Great Recession is the severe credit disruption at the firms' level—debts fell by 26% in real terms over two years.

TABLE 1: Average annualized growth rate in the Employment Cost Index

	2008Q1-2009Q2	2001Q2-2018Q4
All civilians workers	2.11	2.46
Private industry workers	2.12	2.67

SOURCE—Bureau of Labor Statistics

In this paper, I examine the effects of this credit tightening in conjunction with DNWR on the dynamics of hours worked and macroeconomic aggregates. Recent work from the estimation of VAR and DSGE models have established a relationship between adverse financial conditions and the decrease of demand for labor by firms.² For example, from the estimation of a structural factor-augmented vector autoregressive model, [Gilchrist et al. \(2009\)](#) find that credit market shocks measured by corporate bond spreads caused downturns in payroll employment. Moreover, from a Bayesian estimation of a model with financial frictions, [Jermann and Quadrini \(2012\)](#) find that, out

¹For empirical evidence on the US during and following the Great Recession, see [Daly and Hobijn \(2014\)](#), [Daly et al. \(2012\)](#), [Fallick et al. \(2016\)](#), [Grigsby et al. \(2019\)](#), and [Jo \(2019\)](#), for evidence on Canada, see [Brouillette et al. \(2018\)](#), and on Japan during the Lost Decade, see [Kuroda and Yamamoto \(2003\)](#). For evidence on other periods and on other countries, see [Akerlof et al. \(1996\)](#), [Barattieri et al. \(2014\)](#), [Dickens et al. \(2007\)](#), [Gottschalk \(2005\)](#), and [Lebow et al. \(2003\)](#).

²A non exhaustive list of papers includes [Chodorow-Reich \(2014\)](#), [Christiano et al. \(2015\)](#), [Corsello and Landi \(2018\)](#), [Garin \(2015\)](#), [Gertler and Gilchrist \(2018\)](#), [Giroud and Mueller \(2017\)](#), and [Perri and Quadrini \(2018\)](#).

of 8 shocks, financial shocks have the greater explanatory power of the variations in hours worked (33.5%) for the US between 1984Q1 and 2010Q2. I also find significant effects of financial shocks on hours worked, but more interestingly, my major finding is that these effects are amplified by DNWR. Specifically, in the baseline calibration, the maximal deviation of hours worked is 2.15 greater when wages are downwardly rigid compared to when wages are flexible.

My work also contributes to the debate on inflation targeting. Since conventional monetary policy was constrained by the zero lower bound (ZLB) in the aftermath of the Great Recession, some economists have proposed that central banks increase their inflation target from 2% to 4%.³ On the other hand, some work underline that higher inflation targets generate greater welfare costs.⁴ These costs range from a greater volatility of macroeconomic aggregates to a destabilization of inflation expectations, and to greater price dispersion. As a result, all the studies that I cite in footnote 4 propose an optimal level of inflation that is less than 2%.⁵ Contrary to the present paper, their models do not embed financial shocks, which are important to explain the dynamics in the labor market.

The role of DNWR in the context of the optimal inflation rate is examined by [Amano and Gnocchi \(2017\)](#), [Coibion et al. \(2012\)](#), and [Kim and Ruge-Murcia \(2009\)](#). [Coibion et al. \(2012\)](#) show that the presence of DNWR imply less volatile marginal costs and suppresses deflation. As a consequence, the frequency of reaching the ZLB for nominal interest rates is reduced. Since ZLB episodes are costly in terms of welfare, these findings suggest that DNWR lower the benefits of a higher inflation target. Based on the same propagation mechanism, [Amano and Gnocchi \(2017\)](#) find that DNWR decrease the frequency of episodes at the ZLB in a New Keynesian model with preference and technology shocks. Alternatively, [Kim and Ruge-Murcia \(2009\)](#) rely on asymmetric wage adjustment costs to replicate the low frequency of wage cuts in the data. Specifically, downward adjustments of nominal wages are more costly than upward adjustments. For this reason, their optimal inflation rate is positive, yet very small—0.35%.

³See [Ball \(2013\)](#), [Blanchard et al. \(2010\)](#), and [Williams \(2009\)](#).

⁴See [Amano and Gnocchi \(2017\)](#), [Ascari and Sbordone \(2014\)](#), [Ascari et al. \(2018\)](#), [Coibion et al. \(2012\)](#), [Kim and Ruge-Murcia \(2009\)](#), and [Schmitt-Grohé and Uribe \(2010\)](#).

⁵An exception is [Dordal i Carreras et al. \(2016\)](#) who find—from the simulation of a New Keynesian model—that the optimal rate of inflation is very sensitive to the average duration of ZLB episodes, and that an optimal rate of 3% is plausible.

In the present paper, I do not provide a precise value for the optimal level of inflation. However, the effects of financial shocks advocate for a higher inflation target than the ones that are optimal in the aforementioned papers. First, the total losses in hours worked are 27% lower when the inflation target is elevated from 2% to 4%, since there is more room for the adjustment of real wages. Second, contrary to the findings of [Coibion et al. \(2012\)](#) and [Amano and Gnocchi \(2017\)](#), I find that the fall in nominal interest rates is greater with DNWR than with flexible wages in response to negative financial shocks. This finding is related to the fact that financial shocks have more effects on labor demand than other types of shocks. In light of these results, raising the inflation target “greases the wheels” of the economy by entailing two categories of benefits: more efficient real wage adjustments and less ZLB episodes. I focus on the first category of benefits.

The quantitative evaluation of the effects of financial shocks in the presence of DNWR is conducted by the simulation of a nonlinear dynamic general equilibrium model where homogeneous firms are borrowing-constrained à la [Kiyotaki and Moore \(1997\)](#). Since agents in the model are representative, there is no distinction between the intensive and extensive margins of labor supply. As for the other input in the production function, i.e. capital, it is also a collateral asset. In fact, the fraction of capital that can be collateralized varies exogenously over time. I refer to these variations as financial shocks, so that the credit crunch that I simulate consists of sequential negative financial shocks that are similar in size to the credit tightening that firms experienced during the Great Recession.

Firms borrow for two purposes. First, since their owners (entrepreneurs) have a lower discount factor than other agents (households), this induces them to borrow intertemporally. Second, they contract working capital loans due to the assumption that they need to pay their workers before they receive the proceeds of their sales. These loans create a gap between real wages and the marginal product of labor. A tighter borrowing constraint that results from a negative financial shock widens that gap and causes firms to cut down their labor demand. In fact, it is too costly to maintain the same level of working capital when firms are faced with financial negative shocks; so, they reduce their demand for labor. With DNWR, nominal wages hit a lower bound and the ensuing effect is a more severe downward adjustment in hours worked and output in equilibrium.

My work also subscribes to the literature on labor wedges—defined as the gap between the

marginal product of labor and the households' marginal rate of substitution. [Buera and Moll \(2015, p.5\)](#) argue that wedges “may be useful moments for discriminating among alternative models by comparing their responses to a particular shock”.⁶ Moreover, I find that the labor wedge rose to 14.4% in the US during the Great Recession. This change is much greater than changes in investment and efficiency wedges for the same period that [Ohanian \(2010\)](#) documents.⁷ Following a credit crunch, my model overshoots the empirical evidence and delivers a 18.36% increase in the labor wedge. Moreover, due to DNWR, 60.95% of this increase arises from households' equilibrium conditions. This result is in line with empirical evidence that attributes approximately equal shares to the households' and firms' components of the labor wedge.

The rest of the paper is organized as follows. In section 2, I review the literature related to the macroeconomic effects of financial disruptions and DNWR. Section 3 presents the model and the implications of DNWR for the equilibrium in the labor market. Section 4 exposes the parameterization. Section 5 presents the responses to a credit crunch and discusses the quantitative results. Section 6 shows the implications of negative financial shocks in conjunction with DNWR for inflation targets. Section 7 exposes the responses of aggregate variables to TFP and preference shocks. Section 8 concludes.

2 Related literature

[Khan and Thomas \(2013\)](#) conduct a simulation of the credit crisis in a similar fashion to the simulation that I perform in section 5. However, some components of their model differ from mine—*i.e.* the model features heterogeneous producers, investment irreversibilities, and flexible wages. Credit tightening involves reallocation of capital across firms, thereby creating a large and persistent recession. Their model explains 57% of the fall in hours worked. From a model where homogeneous firms face financial frictions, [Jermann and Quadrini \(2012\)](#) find significant effects of financial shocks on labor demand. However, their model also falls short of explaining the drop in hours worked during the Great Recession—their model accounts for around 60% of the decline. In

⁶They show that the effects of a credit crunch manifest as different types of wedges that depends on where the heterogeneity takes place. For heterogeneous recruitment costs, a labor wedge arises.

⁷This finding is also in line with [Brinca et al. \(2016\)](#) and [Ohanian and Raffo \(2012\)](#).

the simulation section, we will see that DNWR amplify the effects of negative financial shocks on hours worked.

The simulation of a credit tightening episode is also shared with [Buera et al. \(2015\)](#). Their model is characterized by the interactions of heterogeneous producers, combined with search and matching frictions in the labor market to allow for the study of unemployment dynamics. Negative financial shocks contribute to the severe decline in output, and the response of unemployment is as large as in the data, but it is delayed. They correct this discrepancy with the data when they replace flexible real wages by fixed real wages. Then, the responses of output and unemployment are almost twice as large. The fixed real wages that are introduced in their model are not exactly the same type of rigidities than the DNWR that I examine. First, the constraint that I consider is on the growth of nominal wages. Second, since this constraint is occasionally binding, agents do not anticipate that nominal wages are fixed forever, and this has some impact on the dynamics of the labor market.

Since the Great Recession, the literature on financial shocks has exploded; however, to the best of my knowledge, my paper is the first one that examines the effects of these shocks in conjunction with DNWR. In the rest of this section, I review papers for which DNWR play a pivotal role.

The models of [Chodorow-Reich and Wieland \(2016\)](#), [Dupraz et al. \(2019\)](#), and [Schoefer \(2015\)](#) feature search and matching frictions in the labor market. In the context of a multi-sector model with imperfect mobility of workers across industries, [Chodorow-Reich and Wieland \(2016\)](#) find that DNWR hinder the reallocation of workers, and that these rigidities are crucial to replicate patterns of cross-sectional employment and wage data. Also, in the lens of a multi-sector model, [Dupraz et al. \(2019\)](#) show that the skewness of unemployment is a by-product of DNWR. Since it produces large losses in welfare, they advocate for a higher inflation target rate. They simulate their model with idiosyncratic and aggregate productivity shocks, and choose the variance of the aggregate shock to match the variance in the post-war U.S. unemployment rate. Hence, they implicitly assume that only this type of shock has contributed to dynamics in the labor market. [Schoefer \(2015\)](#) is more closely related to my work. He embeds financial constraints on firms and incumbents' wage rigidity to a standard search model. Under the assumption that firms have limited access to external funds, he finds that it is optimal for them to cut hiring in response to negative aggregate productivity

shocks, since posting vacancies is costly. This channel has amplified effects as wages become more rigid. My work also highlights the role of the financial sector; however, I show that, in the presence of DNWR, the amplification is greater for financial shocks than productivity shocks.

My work is also related to [Schmitt-Grohé and Uribe \(2013, 2016\)](#), which examine DNWR in an open-economy context. [Schmitt-Grohé and Uribe \(2013\)](#) introduce a simple graphical model to show how an increase in country risk premium can affect aggregate demand and generate involuntary unemployment. Although they do not calibrate nor simulate their model, I presume that this type of external disturbance has different effects than the financial shocks that I examine, since the latter also impact aggregate supply. At the end of their paper, their policy recommends the monetary authority of the eurozone to raise the inflation rate to 4% in order for the unemployment rates of peripheral countries to revert to their pre-crisis levels. [Schmitt-Grohé and Uribe \(2016\)](#) find that DNWR combined with a fixed exchange rate and free capital mobility lead to inefficient allocations. They examine three open-economy policies that can alleviate the adverse effects of interest rate and terms of trade shocks for emerging market countries.

Another strand of related literature studies the effects of DNWR in models that feature heterogeneous agents. Specifically, [Benigno and Ricci \(2011\)](#) introduce idiosyncratic preference shocks to households, who are wage-setters, and derive a closed-form solution of the long-run Phillips curve. For every period, a fixed fraction of households can freely change their wages, while the remaining fraction are facing DNWR. With these rigidities and in the presence of productivity and nominal spending shocks, there are more adjustments in employment than in wages at low inflation. Graphically, it implies that the long-run Phillips is flatter at low inflation compared to high inflation. Given the varying trade-off between inflation and unemployment, [Benigno and Ricci \(2011\)](#) also suggest that the optimal inflation rate is higher for countries that experience a high level of macroeconomic volatility. [Daly and Hobijn \(2014\)](#) use a similar type of model, but their focus is on the short-run Phillips curve and the behavior of unemployment and wage growth during and after recessions. During recessions the wage inflation constraint binds, which implies a Phillips curve that is bent. In the final part of their analysis, they simulate a persistent discount rate shock that resembles a preference shock.

In a similar fashion to [Kim and Ruge-Murcia \(2009\)](#), [Abbritti and Fahr \(2013\)](#) use asymmetric

wage adjustment costs to better explain the skewness of employment and output. They calibrate the parameter that governs the asymmetry in wage costs by matching the skewness of nominal wage changes. With a model that features search and matching frictions in the labor market, and two aggregate shocks—to technology and to the risk premium—they find that asymmetric costs improve the fit of the third moments of aggregate variables. Finally, [Mineyama \(2018\)](#) generates heterogeneity on the workers’ side by introducing idiosyncratic shocks to the disutility of labor. He shows that DNWR are key to explaining the dynamics of inflation and the flattening of the Phillips curve during the Great Recession. However, the degree of asymmetry of the responses in hours worked and in output to positive and negative aggregate discount factor shocks is quite small.

3 Model

The financial frictions embedded in the model are in line with [Kiyotaki and Moore \(1997\)](#) and are similar to the ones introduced by [Liu et al. \(2013\)](#). All agents are infinitely-lived in the economy. Half of them are households and the other half are entrepreneurs that own the firms. Since the discount factor of households is lower than that of entrepreneurs, the former are lenders and the latter are borrowers. Specifically, they face a constraint that restricts their borrowing to a fraction of the capital. Prices are sticky à la [Rotemberg \(1982\)](#), while nominal wage growth cannot be negative. In the rest of this section, I present the optimization problems of both agents in more detail. The full derivation of the first order conditions of the households and the entrepreneurs is located in the appendix.

3.1 Households

Households maximize a discounted sum of their utility that corresponds to the following:

$$E_0 \sum_{t=0}^{\infty} \beta^t \left(\ln c_{Ht} - \frac{\alpha \chi}{1 + \chi} n_t^{\frac{1+\chi}{\chi}} \right) \tag{1}$$

subject to

$$P_t c_{Ht} + b_t = R_{t-1} b_{t-1} + W_t n_t. \tag{2}$$

where β corresponds to the discount factor, α to the weight that they allocate to the disutility of

labor, and χ to the Frisch elasticity of labor supply. They choose inter-temporally their consumption c_{Ht} , hours worked n_t , and their risk-less one-period loan to entrepreneurs b_t , so that their budget constraint holds every period. P_t corresponds to the nominal aggregate price index, R_t to the nominal interest rate on bonds, and W_t to nominal wages. The marginal rate of substitution of consumption for leisure is defined as follows:

$$MRS_t \equiv -\frac{u_{n_t}}{u_{c_{Ht}}} = \alpha c_{Ht} n_t^{\frac{1}{\chi}}, \quad (3)$$

where u_{n_t} and $u_{c_{Ht}}$ correspond to the derivatives of the period utility functions with respect to hours worked and consumption.

3.2 Production and entrepreneurs

There are two stages of production. First, there is a continuum of intermediate good producers in the $[0, 1]$ interval that produce differentiated goods a_{it} . Second, final good producers purchase intermediate goods at price p_{it} . They use these goods as inputs in the production of final goods y_t . Specifically, the intermediate goods are aggregated through a CES production function as follows:

$$y_t = \left(\int_0^1 a_{it}^{\frac{\epsilon-1}{\epsilon}} di \right)^{\frac{\epsilon}{\epsilon-1}} \quad (4)$$

where ϵ corresponds to the elasticity of substitution. Profit maximization leads to the following demand function:

$$a_{it} = \left(\frac{p_{it}}{P_t} \right)^{-\epsilon} y_t. \quad (5)$$

where the aggregate price index $P_t \equiv \left(\int_0^1 p_{it}^{1-\epsilon} di \right)^{1/(1-\epsilon)}$.

The inputs to the intermediate good production are capital k_{it} and labor that are aggregated via the following CES production function:

$$a_{it} = z_t \left(\omega k_{it-1}^{(\sigma-1)/\sigma} + (1-\omega) n_{it}^{(\sigma-1)/\sigma} \right)^{\sigma/(\sigma-1)} \quad (6)$$

where z_t correspond to total factor productivity, ω to the share of capital in production, and σ to the elasticity of substitution between inputs. The Cobb-Douglas production function corresponds

to the particular case where $\sigma = 1$. From the demand function, equation (5), total revenues $p_{it}a_{it}$ can be expressed as $P_t y_t^{1/\epsilon} a_{it}^{(\epsilon-1)/\epsilon}$.

As for pricing, I adopt sticky prices à la [Rotemberg \(1982\)](#). Specifically, firms incur a quadratic adjustment cost for deviating from the inflation target $\bar{\Pi}$:

$$\Psi_{it} = \frac{\psi}{2} \left(\frac{p_{it}}{p_{it-1}} - \bar{\Pi} \right)^2 y_t. \quad (7)$$

Entrepreneurs discount their utility over time at a lower factor than households do ($\gamma < \beta$). For simplification sake, I assume that they do not work. They choose their consumption levels c_{Et} , investment x_t , labor inputs n_t , inter-period debt b_t , and price levels of the intermediate good p_{it} . Their problem is as follows:

$$E_0 \sum_{t=0}^{\infty} \gamma^t \ln c_{Et} \quad (8)$$

subject to

$$P_t c_{Et} + P_t x_t + P_t \Psi_{it} + W_t n_t = b_t - R_{t-1} b_{t-1} + p_{it} a_{it} \quad (9)$$

$$k_t = (1 - \delta) k_{t-1} + \left[\frac{\varrho_1 \left(\frac{x_t}{k_{t-1}} \right)^{1-\nu}}{1 - \nu} + \varrho_2 \right] k_{t-1}, \quad (10)$$

$$a_{it} = \left(\frac{p_{it}}{P_t} \right)^{-\epsilon} y_t, \quad (11)$$

$$b_t + W_t n_t \leq E_t \theta_t q_{t+1} P_t k_t. \quad (12)$$

The left hand-side of equation (9) corresponds to the entrepreneurs' expenses. They consume c_{Et} , they invest x_t , they choose their capital levels k_t , they pay some price adjustment costs Ψ_{it} and they make wage bill payments. On the right hand-side, there is the sum of net borrowing and the revenues from the sale of intermediate goods. Equation (10) corresponds to the law of motion of capital where an adjustment investment cost is embedded. The parameter ν governs the sensitivity of this adjustment cost, while parameters ϱ_1 and ϱ_2 are set such that Tobin's q is equal to 1, and the depreciation of capital is δ in the steady state. Equation (11) is the intermediate good demand function. Finally, equation (12) is an enforcement constraint. I assume that households are paid prior to the sale of intermediate goods, which means entrepreneurs are required to contract interest-

free intra-period working capital loans to cover the wage bill. Moreover, since entrepreneurs are more impatient than households, they have the incentives to borrow inter-temporally the amount b_t . The liabilities of entrepreneurs — the sum of working loans and inter-period debt — cannot exceed a fraction θ_t of the expected value of the collateral $q_{t+1}P_tk_t$ where q_{t+1} corresponds to Tobin's q . This fraction varies over time and reflects the level of credit tightness, so it can be interpreted as a financial shock. I assume that it is persistent and follows an AR(1) process:

$$\theta_t = (1 - \rho_\theta)\bar{\theta} + \rho_\theta\theta_{t-1} + u_{\theta t} \quad (13)$$

where ρ_θ is the persistence parameter, $\bar{\theta}$ corresponds to the steady-state value of θ_t , and $u_{\theta t}$ is the innovation to the shock.

In equilibrium, all intermediate good firms make the same choices. Therefore, $a_{it} = y_t \quad \forall i$, and $p_{it} = P_t \quad \forall i$. In order to achieve a better understanding of the labor market dynamics, the first order condition with respect to hours worked is the following:

$$\left(\frac{\epsilon - 1}{\epsilon}\right) \frac{a_{nit}}{c_{Et}} = \frac{W_t}{P_t} \left(\frac{1}{c_{Et}} + \mu_t\right) + \varphi_t a_{nit} \quad (14)$$

where a_{nit} corresponds to the marginal product of labor. The variables μ_t and φ_t are the Lagrange multipliers to the borrowing constraint and to the demand function. This equation is related to the labor demand. A tighter borrowing constraint leads to a higher value of μ_t . Hence, the two-stage production and the borrowing constraint create a gap between the marginal product of labor and real wages.

3.3 Monetary policy

In order to close the model, I assume that the central bank follows the following Taylor rule:

$$\frac{R_t}{\bar{R}} = \left(\frac{R_{t-1}}{\bar{R}}\right)^{\rho_R} \left[\left(\frac{\Pi_t}{\bar{\Pi}}\right)^{\phi_\Pi} \left(\frac{y_t}{y_{t-1}}\right)^{\phi_y} \right]^{1-\rho_R} \quad (15)$$

where \bar{R} is the steady-state interest rate. The parameter ρ_R governs the persistence of monetary policy, and ϕ_Π , and ϕ_y correspond to the weights allocated to the deviations of inflation from its target and to output growth.

3.4 Equilibrium in the labor market

Since real wages fluctuate along the business cycle, wage inflation Π_{Wt} is not equal to price inflation Π_t . However, they are related in the following manner:

$$\frac{W_t}{P_t} = \frac{\Pi_{Wt}}{\Pi_t} \frac{W_{t-1}}{P_{t-1}}. \quad (16)$$

The nonlinearity in the model comes from the assumption that wage growth must be positive:

$$\Pi_{Wt} = \frac{W_t}{W_{t-1}} \geq 1. \quad (17)$$

From equation (16), this implies that the sum of the inflation of real wage and price inflation must be positive:

$$\pi_{wpt} + \pi_t \geq 0 \quad (18)$$

where $\pi_{wpt} = \Delta \log(W_t/P_t)$ and $\pi_t = \log \Pi_t$.

3.4.1 The labor wedge

Another dimension on which I evaluate the performance of the model following a credit crunch is the labor wedge τ_t . It is defined as the difference between the marginal product of labor (MPN) and the marginal rate of substitution of consumption for leisure (MRS):

$$\tau_t = \log(a_{nit}) - \log(MRS_t). \quad (19)$$

In the equilibrium of a neoclassical model without frictions, the two components are equal to real wages, so there is no movement in the labor wedge. However, in the present model, there are three distortions that govern the dynamics in the labor wedge: (i) the downward nominal wage rigidity, (ii) the two-stage production, and (iii) the borrowing constraint. The first one is related to labor supply and the other twos to labor demand. The latter arises in a similar fashion to [Jermann and Quadrini \(2012\)](#). Following [Karabarbounis \(2014\)](#), I decompose the labor wedge into deviations between the MPN and real wages, and deviations between real wages and the MRS, as follows:

$$\tau_t = \underbrace{\log(a_{nit}) - \log(W_t/P_t)}_{\tau_t^f} + \underbrace{\log(W_t/P_t) - \log(MRS_t)}_{\tau_t^h} \quad (20)$$

where τ_t^f corresponds to deviations that stem from the firms' side and τ_t^h from the households' side.

3.4.2 The effects of a credit crunch on the labor market

In Figure 1, I illustrate the effects of negative financial shocks on real wages and hours worked. The difference between the two panels is the size of the shock. In panel a) the shock is too small to make the wage inflation constraint bind, so the equilibrium is the same as if wages were fully flexible. On the other hand, in panel b) the wage inflation constraint binds. In both panels, the initial equilibria are at point A, and the subsequent ones at point B.

As observed, labor demand shifts down as a result of a tighter borrowing constraint. This stems from equation (12)—as the fraction of capital that the firms post as collateral is lower, their liabilities also need to be reduced. Since working capital loans are a significant part of liabilities, firms decrease them by lowering labor demand. In contrast, labor supply increases following a negative financial shock. Since the shock induces a negative wealth effect, households respond by supplying more work. In equilibrium, the effects of labor demand dominate those of labor supply for the baseline calibration of the model.

Now, let us focus on panel b). First, note that real wages are presented on the vertical axis and not nominal wages. From equation (18), the growth rate of real wages is also bounded. Since negative financial shocks have deflationary effects, this leaves less room for real wages to adjust. In fact, a lower inflation target increases the frequency of the real wage inflation growth equation binding. As a consequence, hours worked drop more when nominal wages are downwardly rigid. Moreover, since the labor supply curve maps the MRS, the distance between points B and C corresponds to the drop in the labor wedge related to households τ_t^h . In contrast, the firms' component of the labor wedge cannot be extracted from Figure 1.

TABLE 2: Parameterization

β	0.99	discount factor (households)
γ	0.98	discount factor (entrepreneurs)
α	10.71	weight on labor disutility
χ	1	Frisch elasticity of labor supply
$\bar{\theta}$	0.75	entrepreneurs' loan-to-value in the s.s.
ρ_{θ}	0.98	persistence of financial shocks
δ	0.025	depreciation of capital
ω	0.36	share of capital in the production function
σ	0.7	elasticity of substitution between capital and labor
ν	0.23	sensitivity of investment to Tobin's q
ϵ	11	intermediate good demand elasticity
ψ	112	price adjustment cost
ρ_R	0.73	persistence of the nominal interest rate
ϕ_{π}	2.57	weight on inflation in the Taylor rule
ϕ_y	0.79	weight on output growth in the Taylor rule
$\bar{\Pi}$	1.005	inflation target

4 Parameterization

In Table 2, I present the parameterization of the model. The households' discount factor correspond to a 4 percent annualized real interest rate in the steady state. I assume that entrepreneurs discount their future period-utilities at a lower rate. Specifically, $\gamma = 0.98$ implies that the internal rate of return is twice the size of the real interest rate. The weight on the disutility of work is governed by $\alpha = 2.25$, so that hours worked are 30% of total time in the steady state. I assume a unitary Frisch elasticity of labor supply $\chi = 1$. As for the financial shock, I follow the calibration of [Liu et al. \(2013\)](#) and set the loan-to-value $\bar{\theta} = 0.75$ which is the average ratio of debt over tangible assets for nonfarm nonfinancial businesses. The persistence of the financial shock ρ_θ is high and set to 0.98. This value is in the ballpark of structural estimates (see *e.g.* [Jermann and Quadrini \(2012\)](#) and [Liu et al. \(2013\)](#)).

The depreciation rate of capital is $\delta = 0.025$ and the share of capital in production is governed by $\omega = 0.36$. The elasticity of substitution between capital and labor is $\sigma = 0.7$. This value corresponds to the point-estimate that [Oberfield and Raval \(2014\)](#) find from data on the cross-section of plants for the US manufacturing sector since 1970. The sensitivity of investment to Tobin's q is governed by $\nu = 0.23$ and is taken from [Jermann \(1998\)](#) which features a model of asset pricing. The elasticity of substitution between intermediate goods and the elasticity of demand are governed by $\epsilon = 11$; this implies a markup of 10%. The parameter that governs the price adjustment cost, $\psi = 112$, is chosen to get a similar slope of the Phillips curve to a model that features Calvo-pricing where the expected life of a price is four quarters. Finally, the monetary policy parameters are taken from [Aruoba et al. \(2017\)](#) and are set to $\rho_R = 0.73$ for the persistence of the nominal interest rate, to $\phi_\pi = 2.57$ for the weight on inflation, and to $\phi_y = 0.79$ for the weight on output growth. The inflation target $\bar{\Pi} = 1.005$ implies a 2% annualized inflation rate. In the next section, I will present changes in the responses of aggregate variables for different inflation targets.

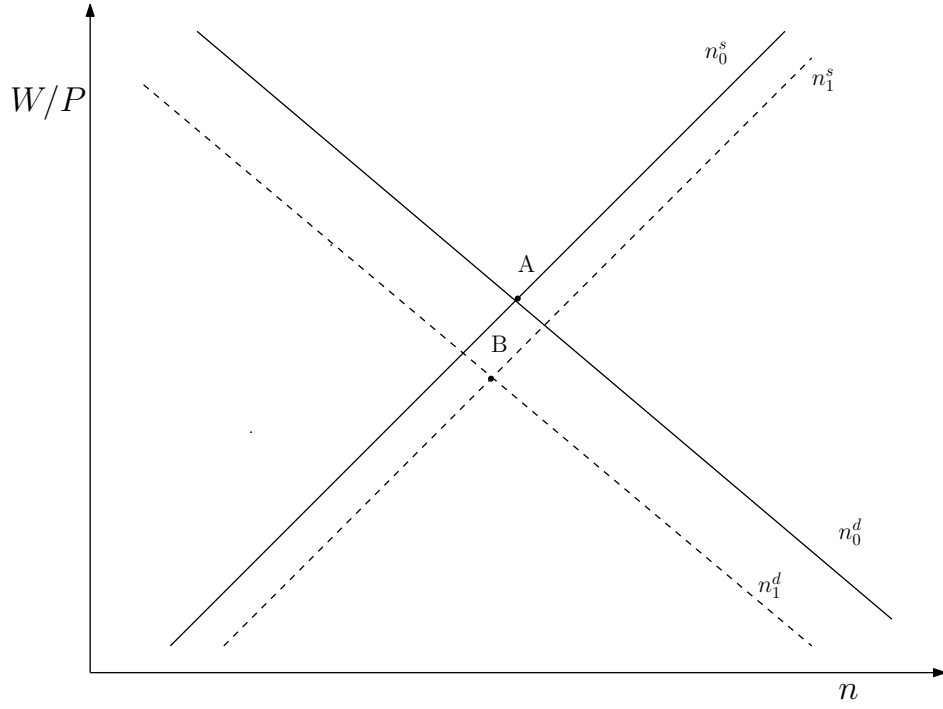

((a)) The wage inflation constraint is **not** binding.

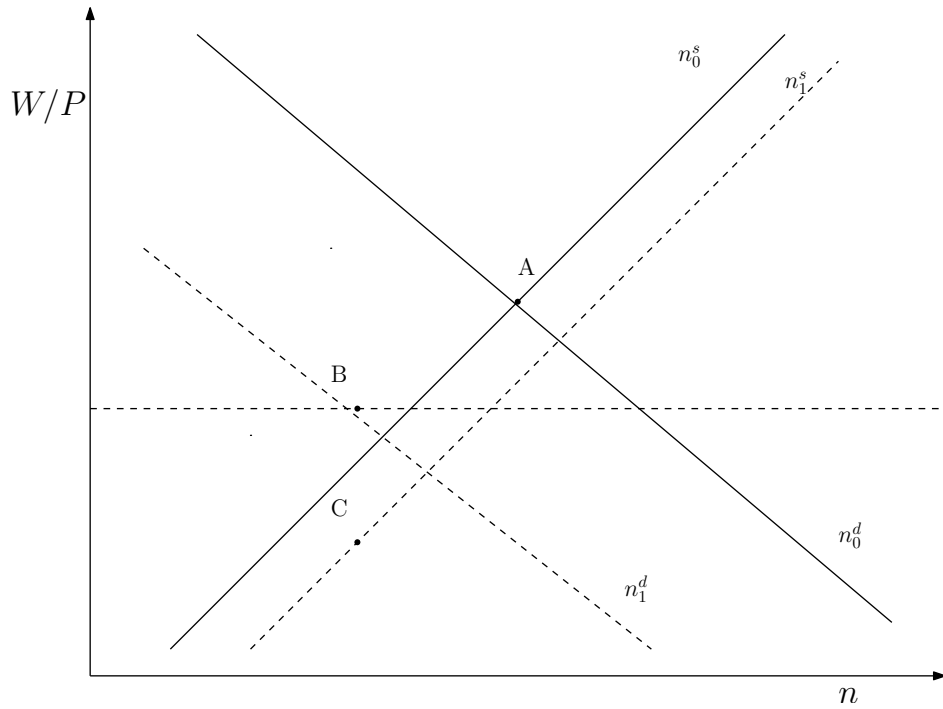

((b)) The wage inflation constraint is **binding**.

Figure 1: The effects of negative financial shocks of different sizes on the labor market equilibria. In panel a) the financial shock is small, and in panel b) it is large.

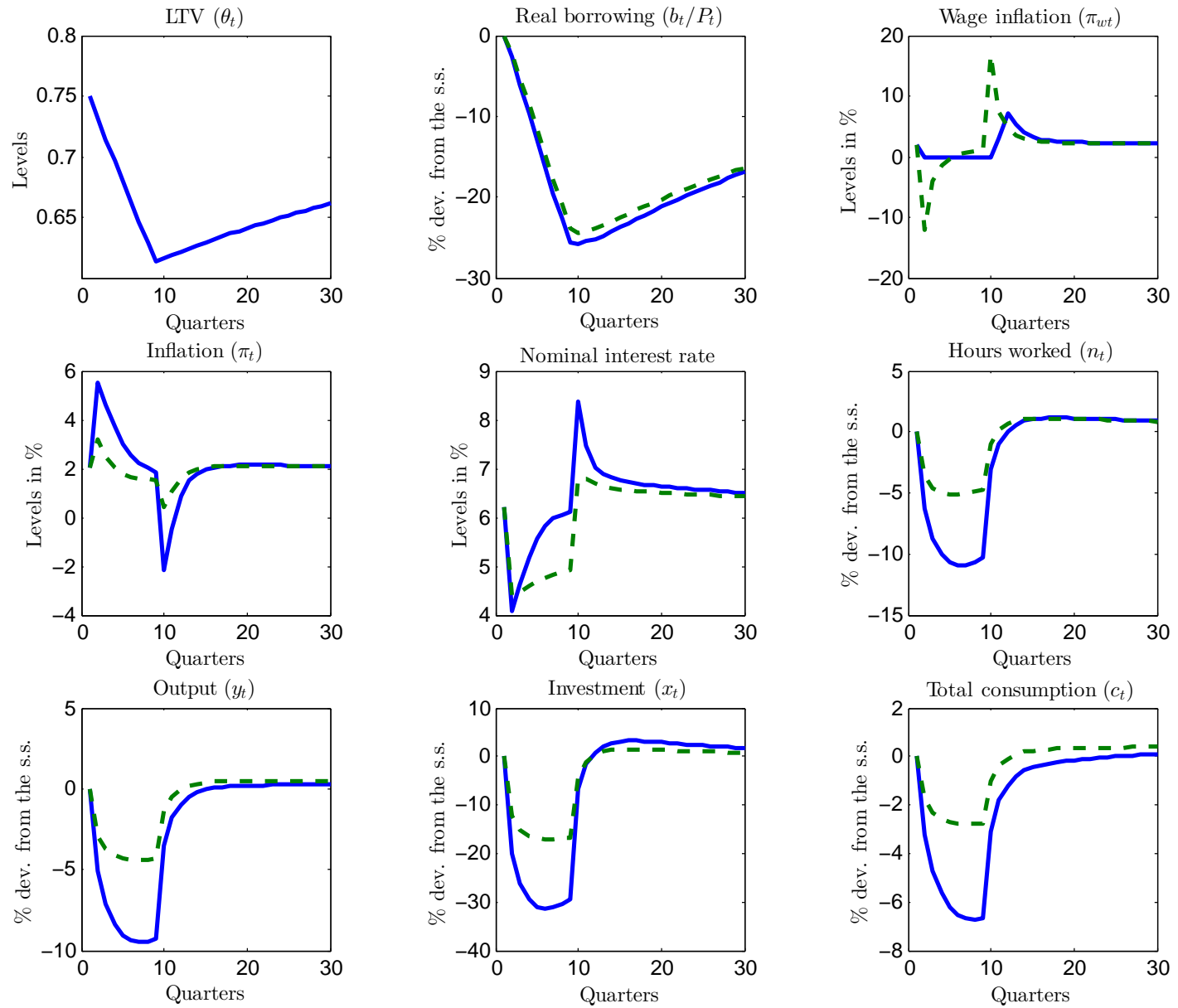

Figure 2: Responses of the main variables to the exogenous variations of the loan-to-value as shown in the top-left panel. The blue solid lines correspond to the responses of the model where nominal wages are downwardly rigid and the green dashed lines correspond to the responses to the same model, but where wages are fully flexible. (**baseline calibration**)

5 The quantitative effects of a credit crunch

In this section, I measure the effects of a credit crunch on main aggregate variables. I follow [Khan and Thomas \(2013\)](#) and chose innovations to the entrepreneurs' loan-to-value, so that their real borrowing in inter-period debt decreases by 26 percent over a period of two years.⁸ This percentage corresponds exactly to the decline in commercial and industrial loans from commercial banks experienced by US firms between 2008Q4 to 2010Q4. The size of the innovations to the loan-to-value is -1.82% per quarter. In the first two panels of [Figure 2](#), I present the evolution of the loan-to-value θ_t and the real borrowing b_t/P_t , respectively. I compare the responses of the baseline model to the same model with flexible wages. Real borrowing does not decrease as much in the flexible wage model, because the cutback in physical capital is not as important.

Since the wage inflation constraint is occasionally binding, it introduces a non-linearity to the model. Therefore, standard perturbation methods that involve a linearization of equations around the steady state cannot be used here. Instead I use the algorithm developed by [Guerrieri and Iacoviello \(2015\)](#), which consists of a piecewise linear approximation. Specifically, their approach involves solving for the dynamics of two regimes: one for which the constraint is binding and another one for which it is not binding. Equations are linearized in both regimes and the probability of switching regimes is endogenous as it depends on the value of state variables. In the remaining panels of [Figure 2](#), I present the evolution of the annualized wage and price inflations, hours worked, output, investment, and total consumption.

As observed in the top-right panel, wage inflation is nil for a total of 9 periods, which implies that real wages are not fully adjusted and the equilibrium in the labor market corresponds to point B in the panel b) of [Figure 1](#). The sequence of negative financial shocks induces firms to cutback their demand for labor. These effects are amplified by DNWR. Specifically, the maximal deviation of hours worked in presence of DNWR is 2.15 times larger than in presence of flexible wages. These effects on the labor market are also reflected in the responses of output, investment, and total consumption (the sum of the consumption of households and entrepreneurs). A lower output supply puts upward pressure on inflation at the onset of the negative sequence of financial

⁸See section VI.C of [Khan and Thomas \(2013\)](#) for a discussion of the extent of the credit crisis.

shocks. Once the sequence of negative financial shocks has ended, output growth is positive and this puts downward pressure on inflation. Therefore, the dynamics of inflation contribute more to the adjustment of real wages at the onset than in the following quarters. Since inflation and output growth are evolving in different directions, the reaction of the interest rate in this simulation is much smaller than the path of the Fed Funds rate during the Great Recession.⁹

In order to assess the importance of DNWR in an environment where the interest rate is more responsive, I increase the weight given to output growth in the Taylor rule ($\phi_y = 2$). Figure 3 presents the responses to the same path of the loan-to-value as in Figure 2. It appears that DNWR amplify the responses of main aggregate variables in the same proportion as they do with a lower weight on output growth. Because of this large amplification effect, the interest rate decreases more when wages are rigid than when they are flexible. This result contrasts with the findings of [Amano and Gnocchi \(2017\)](#) and [Coibion et al. \(2012\)](#). For other types of shocks, they find that the interest rate hits the ZLB more frequently when wages are flexible than when they are rigid. In the simulation presented in Figure 3, the response of the nominal interest rate is above the ZLB. However, the interest rate in the steady state is high (6.2%). If the model were to be calibrated to obtain a lower nominal interest rate, then the economy would be at the ZLB and this would create additional amplification effects for hours worked and output.

In Table 3, I compare the fall in aggregate variables generated by the credit crunch in the baseline model to the data. Another dimension that I examine is the behavior of the labor wedge. For the baseline model, the distance between the MRS and the MPN is 18.36%. This result is close to the empirical estimate of the labor wedge, 14.4%, for the 2007-09 recession. The DNWR play an important role as they explain over 60.95% of the labor wedge. Specifically, the MRS decreases significantly more than real wages as shown by point C in panel b) of Figure 1. The remaining fraction of the labor wedge is explained by the firms' actions. A tighter borrowing constraint effectively leads to a greater distance between the MPN and real wages. The results that I report in the second column allows us to assess the importance of the rigidities in the labor market. In fact, without DNWR, the responses of aggregate variables are about half the size of the responses

⁹Note that for a unitary elasticity of substitution between factors of production, *i.e.* a Cobb-Douglas production function, the responses of aggregate variables are amplified.

	Data	Rigid wages	Flexible wages
Hours worked (n_t)	-9.2	-10.95	-5.08
Real GDP (y_t)	-6.7	-9.46	-4.4
Investment (x_t)	-21.5	-31.34	-17.08
Consumption (c_t)	-2.7	-6.75	-2.78
Labor wedge (τ_t)	14.4	18.36	8.35
% of τ_t explained by			
households (τ_t^h)	50.7	60.95	0
firms (τ_t^f)	49.3	39.05	100

TABLE 3: In the top rows, the deviations from the steady state in % for the baseline model (rigid wages) and for the model with flexible wages after 8 quarters. In the bottom rows the share of the labor wedge explained by the households' and firms' components. The description of the data is provided in Appendix [A](#)

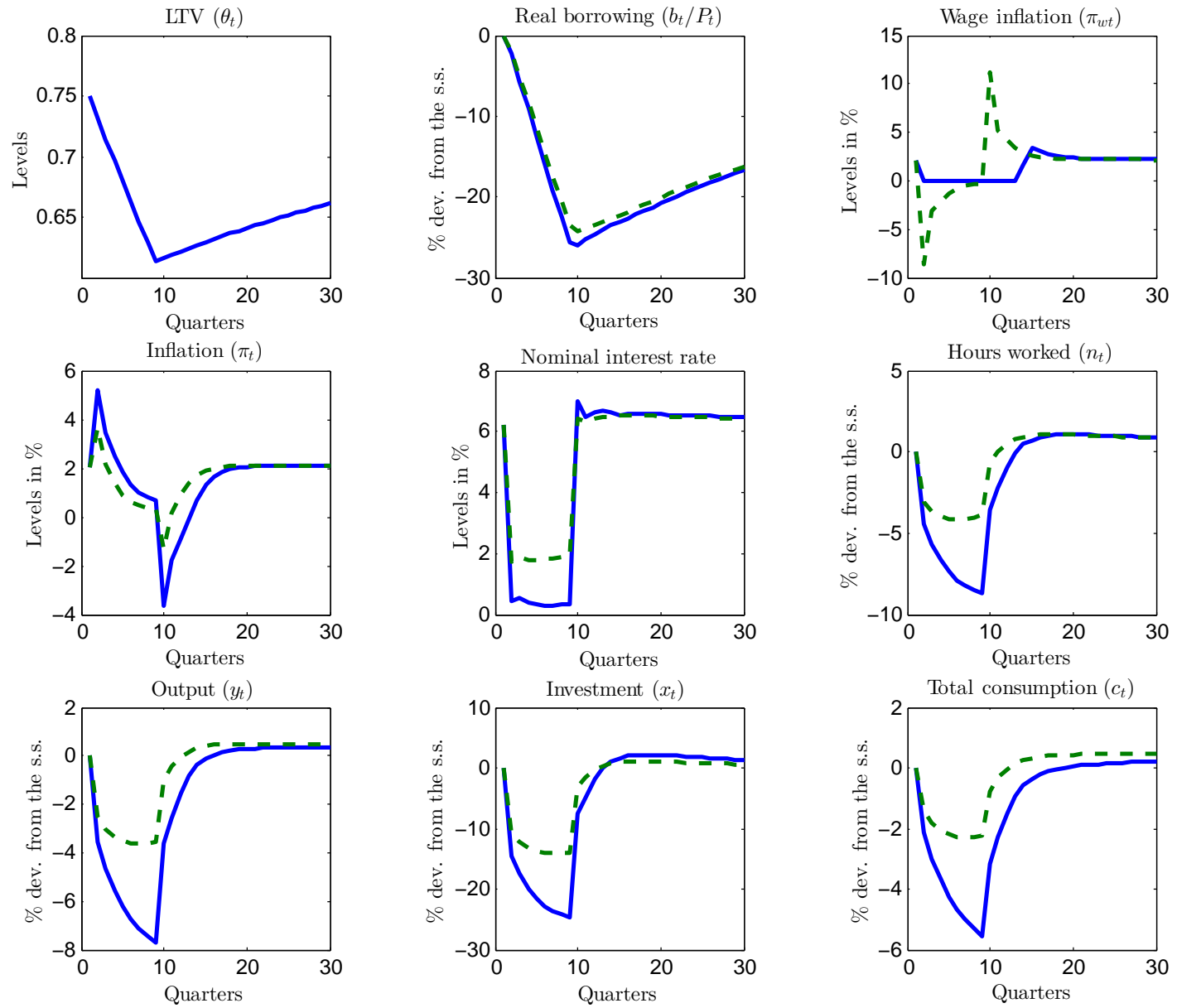

Figure 3: Responses of the main variables to the exogenous variations of the loan-to-value as shown in the top-left panel. The blue solid lines correspond to the responses of the model where nominal wages are downwardly rigid and the green dashed lines correspond to the responses to the same model, but where wages are fully flexible. ($\phi_y = 2$)

of the baseline model with DNWR. Since there is no distortion on the households' side, the labor wedge is explained solely from the firms' component.

6 The implications of DNWR for inflation targeting

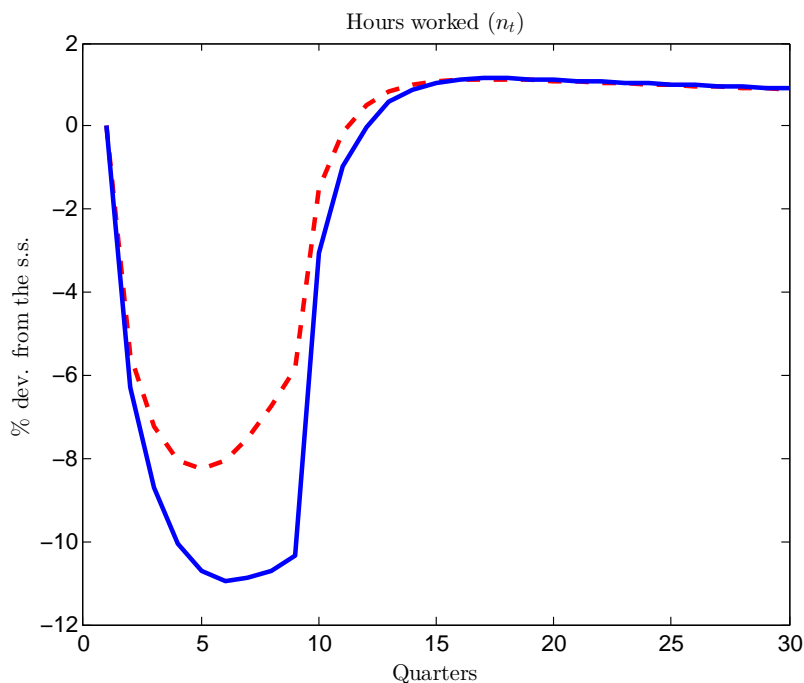

Figure 4: Responses of hours worked to the exogenous variations of the loan-to-value for different inflation targeting regimes. The blue solid line and the red dashed line correspond to the 2% and 4% regimes, respectively. **(baseline calibration)**

In this section, I examine the responses of hours worked to a credit crunch through the lens of a higher inflation-target regime. So far, the inflation target was set to an annualized rate of 2%. In Figure 4, I present the responses for 2%, and 4% inflation targeting regimes. The wage inflation constraint binds for all regimes for at least the quarters for which the innovations to the financial shock are negative. However, the responses are more severe for the 2% inflation-target regime. Specifically, the sum of losses for all hours worked is 27% lower when the inflation target is elevated from 2% to 4%. The ranking of the severity of the decline is the same across all inflation targeting regimes for output, investment, and consumption. The sum of losses of consumption are

32% lower for the 4% inflation-target regime than it is for the 2% inflation-target regime. This result is linked to the fact that the buffer for adjustment of real wages is reduced when inflation in the steady state is close to zero. When nominal wages are fully flexible, the level of inflation targeting does not play any role for the dynamics. Another important result is that hours worked revert to their steady state levels much faster under a higher inflation-target regime.

As a consequence of these results, there are significant benefits for central banks to adopt a higher inflation target when the economy undergoes adverse financial conditions. A richer model is needed to weigh the pros and cons of a higher inflation, because there is no cost at all related to higher inflation in this framework. Nonetheless, in light of these results, it appears that countering a credit crunch requires “greasier wheels”.

7 TFP and preference shocks

We have seen in the previous sections that the effects of a credit crunch are important for aggregate fluctuations. In this section, we study the responses of aggregate variables to total factor productivity and preference shocks.

As shown in equation (6), the TFP shock z_t multiplies the other inputs of the CES production function. I construct the TFP shock as a Solow residual from the production function over the time-period 1964Q1-2016Q4. Between 2007Q4 and 2009Q1, its deviation from an H-P filtered trend, with a smoothing parameter that is equal to 1,600, is -3.6%. Figure 5 presents the responses to this decline in TFP over five quarters. Specifically, TFP follows an AR(1) process as follows:

$$\ln z_t = \rho_z \ln z_{t-1} + u_{zt} \tag{21}$$

where $\rho_z = 0.9626$ is the persistence parameter estimated for US business cycles by [Gomme and Rupert \(2007\)](#), and the innovations to the shock u_{zt} are equal to -0.72%.

A first observation is that the size of the TFP shocks is too small to make the wage inflation constraint bind. Therefore, the responses of the model with DNWR and with flexible wages are exactly the same. In fact, the TFP shock pushes up the price inflation, so that there is more room for the adjustment of real wages. As seen in the middle-right panel, the effects of TFP shocks on

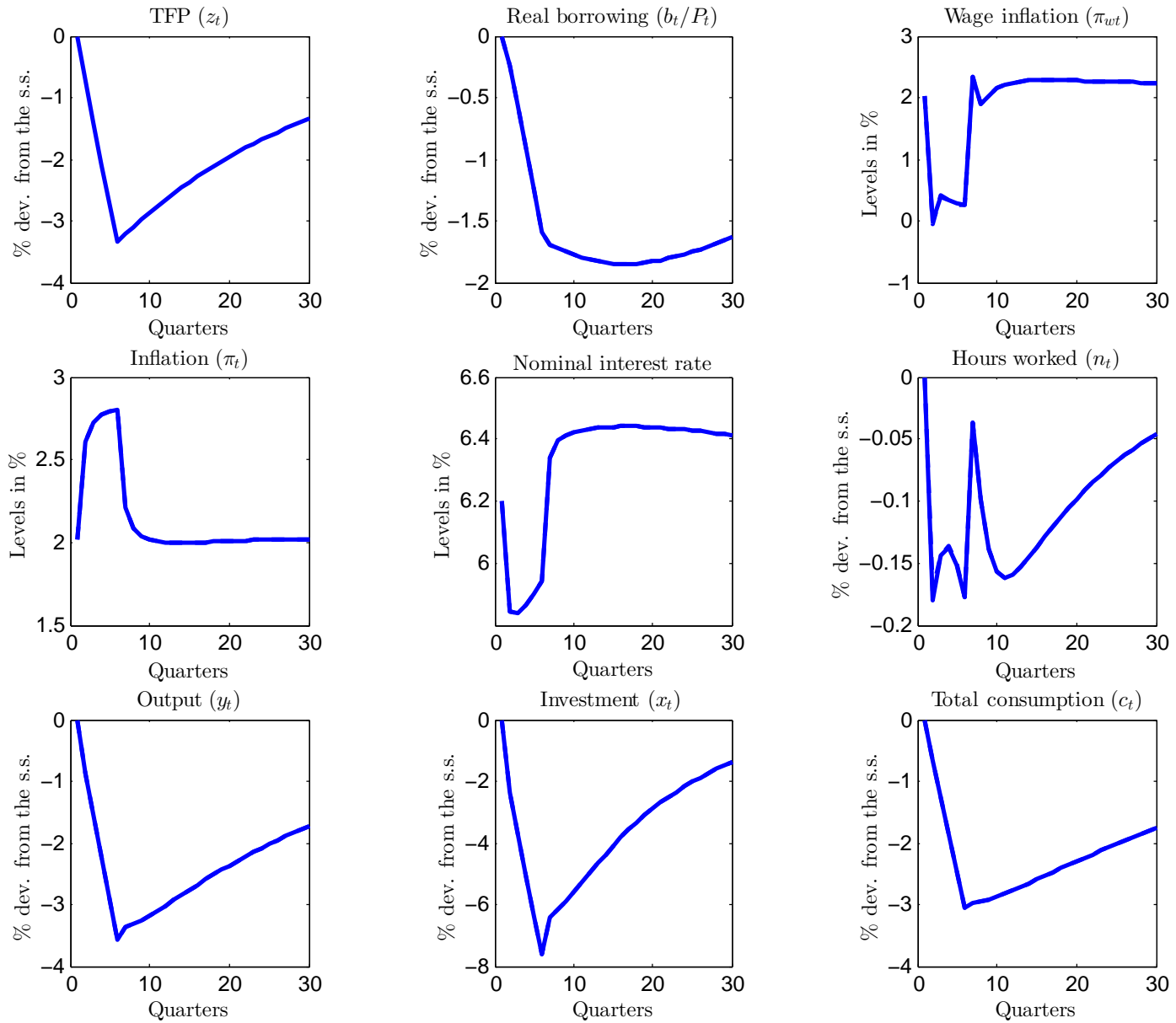

Figure 5: Responses to the exogenous variations in total factor productivity as shown in the top-left panel. The blue solid lines correspond to the responses of the model where nominal wages are downwardly rigid and flexible.

labor demand are not as great as the effects of financial shocks, and are even offset by the effects on labor supply for the quarters subsequent to the initial shock. Specifically, negative TFP shocks loosen the borrowing constraint, since the working capital loans are not as important. As for hours worked, the decrease in labor demand dominates the increase in the labor supply. However, the fall in hours worked is much smaller than the one experienced by the US during the Great Recession. The effects on output are thus mainly driven by the lower exogenous source of TFP and by the reduction in capital that results from a lower marginal product of capital. Finally, also in contrast to financial shocks, TFP shocks do not affect much the conduct of monetary policy.

Figure 6 presents the responses of aggregate variables to a persistent preference shock ξ_t . This shock multiplies the period-utility, so that households maximize the following function:

$$E_0 \sum_{t=0}^{\infty} \beta^t \xi_t \left(\ln c_{Ht} - \frac{\alpha\chi}{1+\chi} n_t^{\frac{1+\chi}{\chi}} \right). \quad (22)$$

The preference shock follows an AR(1) process:

$$\ln \xi_t = \rho_{\xi} \ln \xi_{t-1} + u_{\xi t} \quad (23)$$

where $\rho_{\xi} = 0.812$ is the persistence parameter taken from [Kim and Ruge-Murcia \(2009\)](#) and $u_{\xi t}$ is the innovation to the shock. A negative value of the innovation means that there is less weight allocated to consumption and leisure in the current period. The selected variables that appear in Figure 6 are the responses to a -5.2% shock that corresponds to 2 times the standard error of the innovation also estimated by [Kim and Ruge-Murcia \(2009\)](#).

Since there is less weight allocated to leisure following a negative preference shock, labor supply increases and offsets the effects of labor demand in both settings where wages are flexible and rigid. Moreover, the weight of future consumption increases with respect to contemporaneous consumption. This leads to an increase in savings, which is reflected by the rise in investment in Figure 6. The dynamics of output reflect those of investment and hours worked. Consumption falls as expected, but the effects of the preference shock on other aggregate variables are opposite and counterfactual. Finally, my results differ from those put forward by [Amano and Gnocchi \(2017\)](#), as they find that the zero lower bound is attained more frequently with flexible wages than with

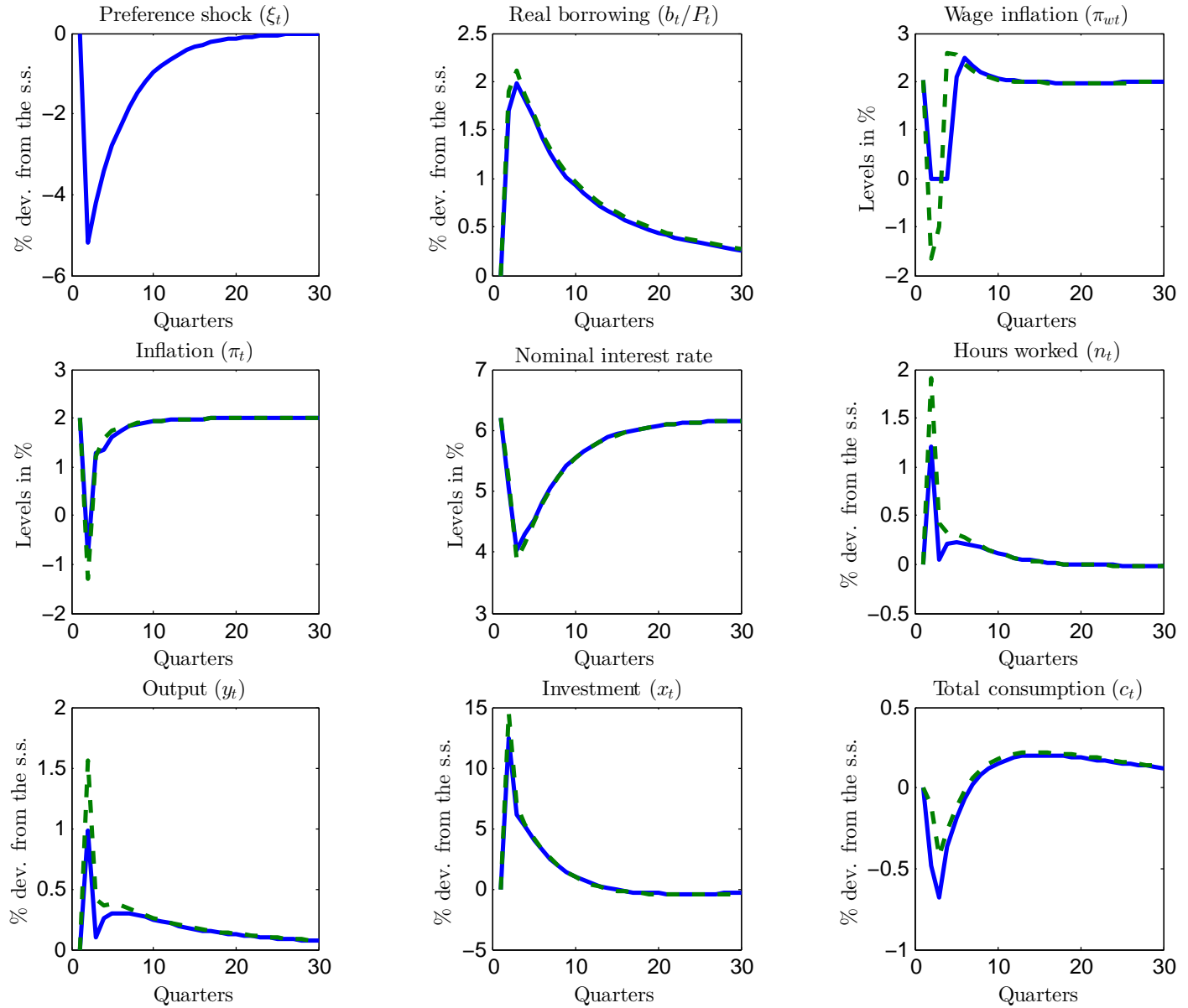

Figure 6: Responses of hours worked to the exogenous variations in the preference shock as shown in the top-left panel. The blue solid lines correspond to the responses of the model where nominal wages are downwardly rigid and the green dashed lines correspond to the responses to the same model, but where wages are fully flexible.

DNWR. The absence of capital and financial frictions in their model might explain the differences of the results.

8 Conclusion

In a dynamic general equilibrium model that features borrowing-constrained firms, negative financial shocks to their collateral constraints impose downward pressure on their demand for labor. When nominal wages are downwardly rigid, these effects are severely amplified. Moreover, the gap between real wages and the households' marginal rate of substitution is widened. Higher inflation targets allow more room for adjustment of real wages, and therefore the effects of negative financial shocks on hours worked and aggregate fluctuations are dampened. Since the effects of TFP and preference shocks on labor demand are not as strong as the effects of financial shocks, I deem them unsuitable to explain the decline of hours worked that the US experienced during the Great Recession.

The results that I obtain are based on a US calibration, but they could be extended to other countries. In fact, [Schmitt-Grohé and Uribe \(2013\)](#) show that these rigidities are prevalent in peripheral countries of the eurozone. Moreover, between 2009Q1 and 2018Q2, commercial and industrial loans dropped by 32.5% and 29.5% in real terms in Greece and in Spain, respectively. An open-economy version of my model could certainly examine the interactions between DNWR and adverse financial conditions in the context of these countries.

References

- Abbritti, M. and Fahr, S.: 2013, Downward Wage Rigidity and Business Cycle Asymmetries, *Journal of Monetary Economics* **60**(7), 871–886.
- Akerlof, G., Dickens, W. R. and Perry, G.: 1996, The macroeconomics of low inflation, *Brookings Papers on Economic Activity* **27**(1), 1–76.
- Amano, R. and Gnocchi, S.: 2017, Downward Nominal Wage Rigidity Meets the Zero Lower Bound, *Staff working paper 2017-16*, Bank of Canada.

- Aruoba, S. B., Bocola, L. and Schorfheide, F.: 2017, Assessing DSGE model nonlinearities, *Journal of Economic Dynamics and Control* **83**, 34–54.
- Ascari, G., Phaneuf, L. and Sims, E. R.: 2018, On the welfare and cyclical implications of moderate trend inflation, *Journal of Monetary Economics* **99**, 56–71.
- Ascari, G. and Sbordone, A. M.: 2014, The macroeconomics of trend inflation, *Journal of Economic Literature* **52**(3), 679–739.
- Ball, L.: 2013, The case for four percent inflation, *Central Bank Review* **13**(2), 17–31.
- Barattieri, A., Basu, S. and Gottschalk, P.: 2014, Some evidence on the importance of sticky wages, *American Economic Journal: Macroeconomics* **6**(1), 70–101.
- Benigno, P. and Ricci, L. A.: 2011, The Inflation-Output Trade-off with Downward Wage Rigidities, *The American Economic Review* **101**(4), 1436–1466.
- Blanchard, O., Dell’Ariccia, G. and Mauro, P.: 2010, Rethinking macroeconomic policy, *Journal of Money, Credit and Banking* **42**(s1), 199–215.
- Brinca, P., Chari, V. V., Kehoe, P. J. and McGrattan, E.: 2016, Accounting for business cycles, *Handbook of Macroeconomics*, Vol. 2, Elsevier, pp. 1013–1063.
- Brouillette, D., Kostyshyna, O. and Kyui, N.: 2018, Downward nominal wage rigidity in Canada: Evidence from micro-level data, *Canadian Journal of Economics* **51**(3), 968–1002.
- Buera, F. J., Fattal Jaef, R. N. and Shin, Y.: 2015, Anatomy of a Credit Crunch: From Capital to Labor Markets, *Review of Economic Dynamics* **18**(1), 101–117.
- Buera, F. J. and Moll, B.: 2015, Aggregate Implications of a Credit Crunch: The Importance of Heterogeneity, *American Economic Journal: Macroeconomics* **7**(3), 1–42.
- Chodorow-Reich, G.: 2014, The employment effects of credit market disruptions: Firm-level evidence from the 2008–9 financial crisis, *The Quarterly Journal of Economics* **129**(1), 1–59.

- Chodorow-Reich, G. and Wieland, J.: 2016, Secular labor reallocation and business cycles, *Technical report*, National Bureau of Economic Research.
- Christiano, L. J., Eichenbaum, M. S. and Trabandt, M.: 2015, Understanding the Great Recession, *American Economic Journal: Macroeconomics* **7**(1), 110–67.
- Coibion, O., Gorodnichenko, Y. and Wieland, J.: 2012, The Optimal Inflation Rate in New Keynesian Models: Should Central Raise Their Inflation Targets in Light of the Zero Lower Bound?, *The Review of Economic Studies* **79**(4), 1371–1406.
- Corsello, F. and Landi, V. N.: 2018, Labor market and financial shocks: a time varying analysis, *Technical Report 1179*, Banca d’Italia.
- Daly, M. C. and Hobijn, B.: 2014, Downward Nominal Wage Rigidities Bend the Phillips Curve, *Journal of Money, Credit and Banking* **46**(S2), 51–93.
- Daly, M., Hobijn, B. and Lucking, B.: 2012, Why has wage growth stayed strong?, *FRBSF Economic Letter* **10**(2).
- Dickens, W. T., Goette, L., Groshen, E. L., Holden, S., Messina, J., Schweitzer, M. E., Turunen, J. and Ward, M. E.: 2007, How wages change: micro evidence from the international wage flexibility project, *The Journal of Economic Perspectives* **21**(2), 195–214.
- Dordal i Carreras, M., Coibion, O., Gorodnichenko, Y. and Wieland, J.: 2016, Infrequent but long-lived zero lower bound episodes and the optimal rate of inflation, *Annual Review of Economics* **8**, 497–520.
- Dupraz, S., Nakamura, E. and Steinsson, J.: 2019, A plucking model of business cycles, *Unpublished manuscript*.
- Fallick, B. C., Lettau, M. and Wascher, W. L.: 2016, Downward Nominal Wage Rigidity in the United States During and After the Great Recession, *Working Paper 1602*, Federal Reserve Bank of Cleveland.

- Garin, J.: 2015, Borrowing constraints, collateral fluctuations, and the labor market, *Journal of Economic Dynamics and Control* **57**, 112–130.
- Gertler, M. and Gilchrist, S.: 2018, What happened: Financial factors in the Great Recession, *Journal of Economic Perspectives* **32**(3), 3–30.
- Gilchrist, S., Yankov, V. and Zakrajšek, E.: 2009, Credit Market Shocks and Economic Fluctuations: Evidence from Corporate Bond and Stock Markets, *Journal of Monetary Economics* **56**(4), 471–493.
- Giroud, X. and Mueller, H. M.: 2017, Firm leverage, consumer demand, and employment losses during the Great Recession, *The Quarterly Journal of Economics* **132**(1), 271–316.
- Gomme, P. and Rupert, P.: 2007, Theory, Measurement and Calibration of Macroeconomic Models, *Journal of Monetary Economics* **54**(2), 460–497.
- Gottschalk, P.: 2005, Downward nominal-wage flexibility: real or measurement error?, *The Review of Economics and Statistics* **87**(3), 556–568.
- Grigsby, J., Hurst, E. and Yildirmaz, A.: 2019, Aggregate nominal wage adjustments: New evidence from administrative payroll data, *Technical report*, National Bureau of Economic Research.
- Guerrieri, L. and Iacoviello, M.: 2015, OccBin: A Toolkit for Solving Dynamic Models with Occasionally Binding Constraints Easily, *Journal of Monetary Economics* **70**, 22–38.
- Jermann, U.: 1998, Asset Pricing in Production Economies, *Journal of Monetary Economics* **41**(2), 257–275.
- Jermann, U. and Quadrini, V.: 2012, Macroeconomic Effects of Financial Shocks, *American Economic Review* **102**, 238–271.
- Jo, Y. J.: 2019, Downward nominal wage rigidity in the United States, *Technical report*, Columbia University.

- Karabarbounis, L.: 2014, The Labor Wedge: MRS vs. MPN, *Review of Economic Dynamics* **17**(2), 206–223.
- Khan, A. and Thomas, J. K.: 2013, Credit Shocks and Aggregate Fluctuations in an Economy with Production Heterogeneity, *Journal of Political Economy* **121**(6), 1055–1107.
- Kim, J. and Ruge-Murcia, F. J.: 2009, How much Inflation is Necessary to Grease the Wheels?, *Journal of Monetary Economics* **56**(3), 365–377.
- Kiyotaki, N. and Moore, J.: 1997, Credit Cycles, *Journal of Political Economy* **105**(2), 211–248.
- Kuroda, S. and Yamamoto, I.: 2003, Are Japanese nominal wages downwardly rigid?(part i): Examinations of nominal wage change distributions, *Monetary and Economic Studies* **21**(2), 1–29.
- Lebow, D. E., Saks, R. E. and Wilson, B. A.: 2003, Downward nominal wage rigidity: Evidence from the employment cost index, *Advances in Macroeconomics* **3**(1).
- Liu, Z., Wang, P. and Zha, T.: 2013, Land Price Dynamics and Macroeconomic Fluctuations, *Econometrica* **81**(3), 1147–1184.
- Mineyama, T.: 2018, Downward nominal wage rigidity and inflation dynamics during and after the Great Recession, *Technical report*.
- Oberfield, E. and Raval, D.: 2014, Micro Data and Macro Technology, *NBER Working Papers 20452*, National Bureau of Economic Research.
- Ohanian, L. E.: 2010, The Economic Crisis from a Neoclassical Perspective, *The Journal of Economic Perspectives* **24**(4), 45–66.
- Ohanian, L. E. and Raffo, A.: 2012, Aggregate hours worked in OECD countries: New measurement and implications for business cycles, *Journal of Monetary Economics* **59**(1), 40–56.
- Perri, F. and Quadrini, V.: 2018, International recessions, *American Economic Review* **108**(4–5), 935–84.

- Rotemberg, J. J.: 1982, Sticky Prices in the United States, *Journal of Political Economy* **90**(6), 1187–1211.
- Schmitt-Grohé, S. and Uribe, M.: 2010, The optimal rate of inflation, *Handbook of Monetary Economics* p. 653.
- Schmitt-Grohé, S. and Uribe, M.: 2013, Downward nominal wage rigidity and the case for temporary inflation in the eurozone, *Journal of Economic Perspectives* **27**(3), 193–212.
- Schmitt-Grohé, S. and Uribe, M.: 2016, Downward Nominal Wage Rigidity, Currency Pegs, and Involuntary Unemployment, *Journal of Political Economy* **124**(5), 1466–1514.
- Schoefer, B.: 2015, *The financial channel of wage rigidity*, PhD thesis, Harvard University.
- Williams, J. C.: 2009, Heeding Daedalus: Optimal Inflation and the Zero Lower Bound, *Brookings Papers on Economic Activity* **2009**(2), 1–37.

A Data used in Table 3

The deviations presented in the data column are the differences in values between their peak and their trough in periods around the Great Recession. The data sources are listed below.

- *Hours worked*: Total private aggregate weekly hours’ from the Current Employment Statistics
- *Real GDP*: Real gross value added: GDP: Business: Nonfarm from the BEA
- *Investment*: Gross fixed capital formation from the OECD
- *Consumption*: Real Personal Consumption Expenditures from the BEA

The variation in the labor wedge ($\Delta\tau_t$) is constructed by taking the difference in the marginal product of labor and the marginal rate of substitution from a neoclassical model and a Frisch elasticity of labor supply of 1:

$$\Delta\tau_t = \Delta \log(y_t - c_t - 2n_t).$$

The fraction of the labor wedge explained by firms corresponds to the variation in the labor share (Nonfarm Business Sector: Labor from the BLS) divided by the variation in the labor wedge. The fraction of the labor wedge explained by households corresponds to the fraction unexplained by firms.

B The model equations

B.1 Households

$$E_0 \sum_{t=0}^{\infty} \beta^t \left(\ln c_{Ht} - \frac{\alpha\chi}{1+\chi} n_t^{\frac{1+\chi}{\chi}} \right) \quad (24)$$

subject to

$$c_{Ht} + \frac{b_t}{P_t} = R_{t-1} \frac{b_{t-1}}{P_t} + \frac{W_t}{P_t} n_t. \quad (25)$$

First-order conditions

c_{Ht} :

$$\frac{1}{c_{Ht}} = \mu_{Ht} \quad (26)$$

b_t/P_t :

$$\mu_{Ht} = \beta R_t E_t \frac{\mu_{Ht+1}}{\Pi_{t+1}} \quad (27)$$

n_t :

$$\mu_{Ht} \frac{W_t}{P_t} = \alpha n_t^{\frac{1}{\chi}} \quad (28)$$

B.2 Entrepreneurs

$$E_0 \sum_{t=0}^{\infty} \gamma^t \ln c_{Et} \quad (29)$$

subject to

$$c_{Et} + x_t + \frac{\psi}{2} \left(\frac{p_{it}}{p_{it-1}} - \bar{\Pi} \right)^2 y_t + \frac{W_t}{P_t} n_t = \frac{b_t}{P_t} - R_{t-1} \frac{b_{t-1}}{P_t} + \frac{p_{it}}{P_t} a_{it} \quad (30)$$

$$\left(\frac{a_{it}}{y_t} \right)^{-1/\epsilon} = \frac{p_{it}}{P_t}, \quad (31)$$

$$\frac{b_t}{P_t} + \frac{W_t}{P_t} n_t \leq E_t \theta_t q_{t+1} k_t. \quad (32)$$

In equilibrium

$$a_{it} = y_t \forall i, \text{ and } p_{it} = P_t \forall i$$

First-order conditions

c_{E_t}:

$$\frac{1}{c_{Et}} = \mu_{E1t} \quad (33)$$

k_t:

$$q_t = \gamma E_t \left[\begin{array}{c} q_{t+1} \left(1 - \delta + \varrho_1 \frac{\nu}{1-\nu} \left(\frac{x_{t+1}}{k_t} \right)^{1-\nu} + \varrho_2 \right) + \\ \mu_{E1t+1} \frac{(\epsilon-1)}{\epsilon} \omega \left(\frac{y_{t+1}}{k_t} \right)^{1/\sigma} - \mu_{E2t+1} \frac{\omega}{\epsilon} \left(\frac{y_{t+1}}{k_t} \right)^{1/\sigma} \end{array} \right] + \theta_t \mu_{E3t} E_t q_{t+1} \quad (34)$$

n_t:

$$\mu_{E1t} \frac{(\epsilon-1)}{\epsilon} (1-\omega) \left(\frac{y_t}{n_t} \right)^{1/\sigma} = \frac{W_t}{P_t} (\mu_{E1t} + \mu_{E3t}) - \frac{(1-\omega)}{\epsilon} \mu_{E2t} \left(\frac{y_t}{n_t} \right)^{1/\sigma} \quad (35)$$

b_t:

$$\mu_{E1t} = \gamma R_t E_t \frac{\mu_{E1t+1}}{\Pi_{t+1}} + \mu_{E3t} \quad (36)$$

P_{it}:

$$\psi(\Pi_t - \bar{\Pi}) y_t \mu_{E1t} = \mu_{E2t} + \gamma \psi E_t \Pi_{t+1} (\Pi_{t+1} - \bar{\Pi}) y_{t+1} \mu_{E1t+1} \quad (37)$$